

AMC Mining Consultants (Canada) Ltd.
BC0767129

200 Granville Street, Suite 202
Vancouver BC V6C 1S4
Canada

T +1 604 669 0044
E vancouver@amcconsultants.com
W amcconsultants.com



Technical Report

NI 43-101 Technical Report Update on the GC Ag-Zn-Pb Project in Guangdong Province, People's Republic of China

Silvercorp Metals Inc.

Guangdong Province, People's Republic of China

In accordance with the requirements of National Instrument 43-101 "Standards of Disclosure for Mineral Projects" of the Canadian Securities Administrators

Qualified Persons:

D. Nussipakynova, P.Geo.

H. Smith, P.Eng., B.Sc., M.Sc.,

A. Riles, B.Met. (Hons), Grad Dipl Business Management, M. Econ. Geol, MAIG (QP)

P. Stephenson, P.Geo., B.Sc., FAusIMM (CP), MAIG, MCIM

AMC Project 718001

Effective date 30 June 2018

1 Summary

Introduction

AMC Mining Consultants (Canada) Ltd. (AMC) was commissioned by Silvercorp Metals Inc. (Silvercorp) to prepare an independent Technical Report (the 2018 Technical Report) on the Gaocheng (GC) property, located in Gaocun Township, Yun'an District, Yunfu City, Guangdong Province, China. AMC has prepared previous Technical Reports on the GC property in 2009 ('NI 43-101 Technical Report Update on the GC Ag-Zn-Pb Project in Guangdong Province, People's Republic of China', effective date 18 June 2009), and 2012 ('NI 43-101 Technical Report on the GC Ag-Zn-Pb Project in Guangdong Province, People's Republic of China', effective date 23 January 2012). Table 2.1 indicates persons who prepared or contributed to the 2018 Technical Report.

Two of the authors of the 2018 Technical Report, Ms Dinara Nussipakynova and Mr Herbert Smith of AMC, visited the GC property in January 2018. All authors of this report qualify as Independent Qualified Persons.

In preparing this report, AMC has relied on various geological maps, reports, and other technical information provided by Silvercorp. AMC has reviewed and analysed the data provided and drawn its own conclusions augmented by its direct field observations. Much of the geological information in this report was originally written in Chinese. Translations of key technical documents and data into English were provided by Silvercorp. The Qualified Persons have no reason to believe that the translations are not credible and believe they are generally reliable but cannot attest to their absolute accuracy.

Location, ownership, and history

The GC property is located in the vicinity of Gaocheng village, Gaocun Township, Yun'an District, Yunfu City, Guangdong Province, People's Republic of China. The Property is located west of the metropolitan city of Guangzhou, the capital of Guangdong Province. Guangzhou is located about 120 km northwest of Hong Kong and has a total population of almost 14 million residents, as of December 2016. Access to the GC project from Guangzhou is via 178 km of four-lane express highway to Yunfu, then 48 km of paved road to the project site.

Silvercorp owns 95% of the GC Mine through its 100% ownership of the shares of Yangtze Gold Ltd. (Yangtze Gold), which in turn wholly owns Yangtze Mining Ltd. (Yangtze Mining). Yangtze Mining owns a 95% interest in a Sino-Foreign joint venture company, Anhui Yangtze Mining Co. Ltd. (Anhui Yangtze). Guangdong Found Mining Co. Ltd. (China), (Guangdong Found), is the designated joint venture operating company of the GC Mine.

The Mining Permit in the name of Guangdong Found is valid for 30 years to 24 November 2040, covers the entire 5.5238 km² area of the GC Mine and permits mining from 315 m to minus 530 m elevations. The permit allows for the operation of an underground mine to produce silver, lead and zinc.

Currently, GC Mine is subject to mineral resources tax, levied at 3% of sales. This tax together with other government fees totals around 5% of net revenue. AMC is not aware of any additional royalties, back-in rights, payments, agreements, environmental liabilities, or encumbrances particular to the property other than those stated above.

Various state-sponsored Chinese Geological Brigades and companies have conducted geological and exploration work in the project area with systematic regional geological surveys commencing in 1959. Historical drilling commenced in 2001.

Prior to Yangtze Mining acquiring the GC Property in 2005, illegal mining activity resulted in the excavation of several tunnels and small-scale mining of veins V2, V2-2, V3, V4, V5, V6, and V10. It is reported that a total of 1,398 m of excavation comprised of 10 adits and tunnels had been completed on the property through the illegal activity.

A total of 43 diamond drillholes for a combined total of 13,463.74 m was drilled on the GC property between 2001 and 2007 prior to the property acquisition by Silvercorp. Diamond drillholes were drilled using PQ size in overburden, then reduced to HQ size for up to 100 m depth.

The Guangdong Provincial Institute of Geological Survey (GIGS) prepared a resource estimate for nine mineralized veins for the GC project after the 2004 – 2005 exploration season. This was not compliant with CIM Standards.

Geology and mineralization

The GC property is located on the east margin of the Luoding basin, east of the Wuchuan – Sihui major fault within the north portion of the Yunkai uplift of the South China Orogenic Belt. Northeast striking structures and arc structures form the basic geological framework of the region. Deposits on the property occur at the intersection of a north-easterly striking fault zone and a near east-westerly striking fault zone.

Basement geology in the area comprises late Proterozoic Sinian sedimentary clastics and carbonate rocks; Palaeozoic (Ordovician, Silurian, Devonian, Carboniferous) sedimentary clastics and carbonate rocks; and Mesozoic (Triassic) coal-bearing clastic rocks and Cretaceous red clastic rocks. Ag-Pb-Zn poly-metallic deposits occur within late Proterozoic rocks. Cu-Pb-Zn, Mn, and Au-Ag deposits occur within Palaeozoic rocks.

The GC Project is located at the intersection between the Wuchuan-Sihui Deep Fault zone and Daganshan Arc-ring structural zone. It is situated in the southwest part of the Daganshan uplift. Structures developed in the area are mainly the NWW-EW striking Gaocheng Fault zone, the NE striking Baimei Fault zone, and the Songgui Fault zone.

Basement rocks within the GC Project area encompass quartz sandstone, meta-carbonaceous siltstone, carbonaceous phyllite, calcareous quartzite, and argillaceous limestone of the Sinian Daganshan Formation; quartz sandstone and shale of the Triassic Xiaoyunwushan Formation, and sandy conglomerate and conglomerate of the Cretaceous Luoding Formation. These rocks are intruded by Palaeozoic gneissic, medium-grained biotite granite, and Mesozoic fine- to medium-grained adamellite, brownish, fine-grained, biotite mylonite, granite porphyry, quartz porphyry, diabase, and aplite. The Mesozoic intrusives intruded along the south and southwest contacts of the Palaeozoic granites. The majority of Ag-Zn-Pb mineralization is hosted by the Mesozoic granite. The granite dips south and strikes west northwest, parallel to the majority of mineralized veins on the GC property.

Mineralization at GC is primarily hosted within a WNW-ENE trending, 4.8 km long and 2 km wide fault zone. This zone encompasses numerous veins which strike between 112° and 146° and dip between 65° to the southwest and sub-vertical. The average thickness of these veins is 0.89 m.

There are east-west striking veins which typically strike 65° to 110° and dip between 59° and sub-vertical to the SE and SSW. The average thickness is around 0.9 m.

NE-striking faults cut through the NWW-striking structures with no or minor displacement. These veins are sub-parallel to major NE striking faults and strike between 20° and 78° and dip between 60 and 84° to the SE. The average thickness of these veins is 0.68 m.

Ag-Pb-Zn mineralization at the GC deposit can be divided into two types: primary and oxidized. The primary mineralization is mainly composed of galena-sphalerite-silver minerals, which occur sparsely, as disseminations, veinlets, and lumps. Primary mineralization accounts for 95% of the entire mineral resource. Oxide mineralization occurs on and near the surface.

Mineralized veins in the GC area occur in relatively permeable fault-breccia zones. These zones are extensively oxidized from the surface to depths of about 40 m. Veins in this zone exhibit open space and boxwork lattice textures resulting from the leaching and oxidation of sulphide minerals. Secondary minerals present in varying amounts in this zone include kaolinite, hematite and limonite.

The dominant sulphide mineral is pyrite, and other constituents are a few percent of sphalerite, galena, pyrrhotite, arsenopyrite, magnetite, and less than a percentage of chalcopyrite and cassiterite. Gangue minerals include chlorite, quartz, fluorite, feldspar, mica, hornblende, with a small amount or trace amount of kaolinite, tremolite, actinolite, chalcedony, garnet, zoisite, apatite, and tourmaline.

Alteration minerals associated with the GC vein systems include quartz, sericite, pyrite, and chlorite, together with clay minerals and limonite. Silicification commonly occurs near the centre of the veins. Chlorite and sericite occur near and slightly beyond the vein margins.

Quartz, pyrite, fluorite, and chlorite are closely related to the mineralization.

The poly-metallic mineralization of the GC deposit belongs to the mesothermal vein infill style of deposit.

Exploration and data management

Silvercorp has carried out surface and underground exploration activities since 2008.

Surface-based exploration occurred primarily during 2008, which included soil sampling, geological mapping and trenching. Following up on geochemical anomalies Silvercorp conducted trenching and pitting programs that exposed the mineralized veins on the surface and at shallow depth. A total of seven pits and one trench were excavated by Silvercorp exposing three veins.

More than 40 km of underground tunnelling and sampling at the Property was carried out between 2012 and 2017. These programs comprised 27,403 m of drifting along mineralized structures, 7,292 m of crosscutting across mineralized structures, and 6,167 m of raises. Drifts and crosscuts were developed at 40 m intervals vertically to increase geological confidence in the Mineral Resource.

A total of 44,166 channel / chip samples were collected from the mine areas during the period, with samples being assayed for Ag, Pb, and Zn.

Silvercorp completed its first phase of diamond drilling on the GC property in 2008. Systematic drilling commenced on the property in 2011 and continued through to 2017. All Silvercorp drilling was completed as NQ-sized core. Drillhole collars were surveyed using a total station and down hole surveys were completed every 50 m downhole. Core recoveries varied between 41.7% and 100%, averaging 96.9%. AMC reviewed the relationship between grade and core recovery and found no bias.

The majority of drillholes were drilled as inclined holes to test multiple vein structures. Underground drillholes were drilled as fans of multiple holes from single set-ups.

Drill core processing is completed by Guangdong Found employees in accordance with a standard procedure. Core recovery is measured followed by detailed logging of the core with lithological, vein and mineralization contacts identified and recorded. The core is photographed and sampled on 1.5 m maximum intervals and at geological or mineralization contacts. Core is cut in half with a rock saw with one half bagged and secured for shipment to the laboratory, and the other half retained in the core tray for future reference.

Channel samples are collected along sample lines perpendicular to the mineralized vein structure as well as from walls of cross-cut tunnels and bottom of trenches. Samples include vein material and associated wallrock.

Between 2008 and 2014 samples were prepared and analysed by ALS Chemex in Guangzhou (ALS Guangzhou), Guangdong Province, China. This is accredited with International Standards Organization (ISO) 9001:2015 and China National Accreditation Service (CNAS). Commencing in 2012 Silvercorp shipped samples to the Gaocheng onsite laboratory in addition to ALS. GC Lab became the primary laboratory in 2014 and is not accredited.

All data for the GC Project is stored within a central Access Database which is managed by two designated database administrators. All data collection and storage are standard with most data including the laboratory data being uploaded from Excel into the Access database.

QA/QC protocols are fairly industry standard. Certified Reference Materials (CRMs) have been routinely inserted since 2011. Blank (uncrushed) samples and coarse duplicates have been inserted since 2012 (drilling) and 2014 (underground sampling). Umpire samples (pulp duplicates) have been sent to a different laboratory since 2011.

It is noted that the CRM insertion rate for drillhole sample batches and underground chip sample batches has been 2 – 4%. Also, CRM performance has not, to date, been monitored on a batch by batch basis. This rate should be increased to 5% and remedial action taken in real time, based on the control charts which are compiled on a batch by batch basis. Umpire assay duplicates have been used and show acceptable results with no systematic bias. The rate of insertion of umpire duplicate samples should be increased to 5% for both drillhole and underground chip samples.

The QP has highlighted some issues for improvement in the QA/QC process, however it considers the assay database to be acceptable for Mineral Resource estimation.

Data verification was carried out by the QP with 5% of the samples being verified in the database. Of the 11,171 samples contained within the vein domains, 612 samples were verified, 6 errors were found, and 18 assay certificates not located. The six errors represent around 1%. Further validation of the database is recommended to identify and correct any remaining errors.

The QP does not consider these issues to have a material impact on Mineral Resource estimates and considers the assay database to be acceptable for Mineral Resource estimation.

Mineral Resource estimates

The Mineral Resources for the GC deposit have been prepared by Mr Shiping Yin, Resource Geologist of Silvercorp. Ms Dinara Nussipakynova, P.Geo., of AMC, has reviewed the methodologies and data used to prepare the Mineral Resource estimates and, after changes to the Mineral Resource classification, she is satisfied that they comply with reasonable industry practice. Ms Nussipakynova takes responsibility for these estimates.

AMC is not aware of any known environmental, permitting, legal, title, taxation, socioeconomic, marketing, political, or other similar factors that could materially affect the stated Mineral Resource estimates.

The data used in the Mineral Resource estimation includes results of all drilling carried out on the Property to 31 December 2017. The estimation was carried out in Micromine™ software. Interpolation was carried out using inverse distance cubed (ID³) for all the veins.

Table 1.1 Summary of Mineral Resources as of 31 December 2017

Resource classification	Tonnes (Mt)	Ag (g/t)	Pb (%)	Zn (%)	Contained metal		
					Ag (koz)	Pb (Mlbs)	Zn (Mlbs)
Measured	2.735	101	1.4	3.2	8,840	84	195
Indicated	3.638	92	1.2	2.7	10,818	98	217
Measured and Indicated	6.374	96	1.3	2.9	19,658	181	412
Inferred	7.481	107	1.2	2.6	25,662	196	429

Notes: CIM Definition standards (2014) were used for reporting the Mineral Resources

Mineral Resource are reported at a cut-off grade of 100 g/t AgEq.

The equivalency formula is $Ag\ g/t + 44.6 * Pb\ \% + 43.5 * Zn\ \%$ using prices of \$19/oz Ag, \$1.00/lb Pb and \$1.25/lb Zn and estimated recoveries of 77% Ag, 86% Pb, and 83% Zn.

Drilling results up to 31 December 2017.

Mineral Resources that are not Mineral Reserves do not have demonstrated economic viability.

The numbers may not compute exactly due to rounding.

Source: Silvercorp, reproduced as a check by AMC Mining Consultants (Canada) Ltd.

The GC deposit consists of 89 veins, each of which has a separate block model. Approximately 16,000 m of channel samples and 27,800 m of core samples from 1,050 drillholes form the basis of the estimate. Capping is employed on the raw data and the composite length equals the vein thickness.

The parent block size for all veins was 1 m by 2 m by 2 m (x, y, z) with block percentages employed. In order to check the estimates AMC imported all 89 block models and, based on provided wireframes, created sub-celled models for better representation of the mined-out volumes.

Interpolation was carried out using the inverse distanced cubed (ID³) method. Mining depletion and write-offs based on survey information to 31 December 2017 were coded into the block models by Silvercorp.

On review of the classification, AMC revised the classification system using an assessment of mineralization continuity, data quality and data density, with data density being the main criterion. Mineral Resources were classified as Measured, Indicated, and Inferred.

The block models were validated by AMC in four ways. First, visual checks were carried out to ensure that the grades respected the raw assay data. Secondly, swath plots were reviewed. Thirdly, the estimate was statistically compared to the composited assay data, with satisfactory results. Lastly, eight block models were re-estimated using independent parameters and ordinary kriging. The results of the OK estimate compared favourably with the ID³ estimates.

Mineral Reserve estimates and mining

To convert Mineral Resources to Mineral Reserves, mining cut-off grades have been applied, mining dilution has been added and mining recovery factors assessed on an individual vein mining block basis. Only Measured and Indicated Resources have been used for Mineral Reserves estimation.

The Mineral Reserve estimates for the Gaocheng property were prepared by Silvercorp under the guidance of independent Qualified Person, Mr H. Smith, P.Eng., who takes QP responsibility for those estimates.

The Mineral Reserve estimation is based on the assumption that stoping practices will continue to be shrinkage stoping with a relatively small amount of cut and fill resuing. Minimum mining widths of 1.0 m for shrinkage and 0.5 m for resuing, and dilution of 0.20 m total for shrinkage and 0.10 m for resuing cut and fill stopes are assumed. Cut off grades used are 180 g/t AgEq for shrinkage and 245 g/t AgEq for resuing.

Table 1.2 summarizes the Mineral Reserves estimate for the Gaocheng mine. 47% of the Mineral Reserve tonnage is categorized as Proven and 53% is categorized as Probable.

Table 1.2 Gaocheng mine Mineral Reserves estimate at 31 December 2017

Reserve classification	Tonnes (Mt)	Ag (g/t)	Pb (%)	Zn (%)	Contained metal		
					Ag (koz)	Pb (Mlbs)	Zn (Mlbs)
Proven	1.691	96	1.4	3.2	5,219	53	120
Probable	1.873	97	1.4	2.9	5,841	58	121
Proven and Probable	3.564	96	1.4	3.1	11,000	112	240

Notes to Mineral Reserve Statement:

Full breakeven cut-off grades: Shrinkage = 180 g/t AgEq; Resuing = 245 g/t AgEq.

Marginal material cut-off grade: 145 g/t AgEq.

Dilution (zero grade) assumed as 0.1 m on each wall of a shrinkage stope and 0.05 m on each wall of a resuing stope.

Mining recovery factors assumed as 95% for resuing and 92% for shrinkage.

Metal prices: Silver US\$19/troy oz, lead US\$1.00/lb, zinc US\$1.25/lb.

Processing recovery factors: Ag - 77%, Pb - 86%, Zn - 83%.

Effective date 31 December 2017.

Exchange rate assumed is RMB 6.50: US\$1.00.

Rounding of some figures may lead to minor discrepancies in totals.

Since the start of mining operations through to the end of 2017, a total of 988,000 tonnes has been milled from pre-and post-commercial production mined at Gaocheng. The comparison of the head grades to date with the current Mineral Reserve estimates shows a reduction in silver grade of 2%, a reduction in lead grade of 5%, and an increase in zinc grade of 13% in the Mineral Reserves.

Mining to date has been conducted in two stages. Stage 1 targeted bringing the project into production as soon as practicable using mobile, rubber-tired, diesel-powered equipment (development jumbo, loader and truck) with surface declines access down to -50 mRL. Stage 2 development from -50 mRL down to -300 mRL employs conventional tracked equipment (battery powered locomotives, rail cars, electric rocker shovels and pneumatic hand-held drills) via a surface shaft access. In-stope rock movement is by gravity to draw points or hand-carting to steel-lined passes.

The rock mass condition is categorized as Fair to Good and it is anticipated that the vein and host rocks in the mine area will continue to be largely competent and require minimal ground support other than in weaker ground areas.

A pillar is maintained around the Main Shaft. Development may occur within the pillar zone, however stope production will not be allowed. The shaft pillar is an expanding cone with a dip from the collar elevation of 80°. The pillar radius at surface (248 mRL) is 13 m and the Main Shaft radius is 3 m.

Relative to the Mineral Reserve estimates in the previous Technical Report (2012 Technical Report - pre-operations), there is a 264% increase in Proven Mineral Reserve tonnes and a 56%

decrease in Probable Mineral Reserve tonnes, with a decrease in Mineral Reserve total tonnes of 25% (1,186,000 t).

Metallurgy and processing

Since the 2012 Technical Report no further metallurgical testing has been done, but the mill functioned in a trial mode up to 2014 and, from that point (FY2015 starting Q2 2014), has been in commercial production.

Metallurgical testing for the GC project was carried out by the Hunan Research Institute of Non-Ferrous Metals and reported in May 2009 in the report "Development and Research of the Comprehensive Recovery Test of Lead Zinc Silver Tin Sulphur for the Lead Zinc Ore Dressing in GC Mine Area". This report was made available to AMC in English translation by Silvercorp. The testwork was also summarized in the January 2011 GMADI report as part of the "Design Instructions" for the plant design.

The objectives of the testwork were, following on from previous testwork of 2007 on samples from artisanal mining dumps, to i) maximize silver recovery to the lead concentrate, ii) investigate the potential for tin recovery, iii) develop a process flow sheet with appropriate operating parameters as a basis for the industrial scale implementation of lead, zinc, sulphur (and possibly tin) recovery, and iv) determine the product quality characteristics relative to the relevant national standards.

Since the start of trial operations in 2013 and commercial production in 2014, lead and zinc concentrates have been produced in commercial quantities at the Gaocheng mill. The overall process consists of crushing, grinding, sequential flotation of lead, zinc and pyrite concentrates, and concentrate dewatering by disc filtration. An experimental tin recovery gravity separation circuit is installed on pyrite flotation tails.

Two-stage crushing is carried out, with the second stage in closed circuit. Run of mine ore at -350 mm is reduced to crusher product at -10 mm. This is followed by two-stage grinding in ball mills to a product size of 80% passing 75 µm (P_{80} of 75 µm).

The flotation process consists of a standard flotation of lead, with three-stage cleaning of the lead concentrate, then flotation of zinc concentrate with three-stage cleaning; leaving pyrite tailings as S concentrate. Concentrates are dewatered by conventional thickening and filtration.

Trucks under escort by security personnel are used to transport lead and zinc concentrates from the mine site to refineries. A front-end loader is used to load the concentrate from storage sheds near filters at the mill site to the concentrate shipping trucks.

Since completion of commissioning, the plant has processed approximately the same amount of ore each year (approximately 250 ktpa).

There is a laboratory on site equipped with the customary sample preparation, wet chemistry, and basic photometric analytical equipment; as well as crushing, grinding, flotation, and gravity-separation metallurgical testing equipment.

Project infrastructure

The filtered tailings are conveyed to the TMF area via conveyor and then spread by bulldozer on a bench-by-bench basis. The tailings deposition method is dry stacking and filling (from bottom to top and stacking by bench to form the embankment), with concurrent rolling and compaction to the desired dry density standards.

The waste rock dump is located a short distance to the east of the mine portal. It is understood to have an immediate capacity of the order of 275,000 m³ (~558 kt). Underground waste rock produced to date has largely been used for construction purposes by Silvercorp or transported off site by local area persons, free of charge, again to be used for construction activities. The removal of waste rock from site is anticipated to continue for the foreseeable future. Waste rock could opportunistically be disposed of into shrinkage stope voids (with approximately 1.2 Mm³ or 2.3 Mt void capacity) but this is not in the current mine plan.

Based on the GC environmental assessment report, AMC understands that waste rock at the GC mine has no significant acid-generating potential.

There is a 110 kV substation near Gaocun, about 6 km from the mining area. This is fed from the Guangdong Province electrical grid system. Silvercorp uses this substation as the main source of power for the mine. Currently there are two overhead power lines for the 6 km route. Two 1,500 kW diesel generators are designated for emergency backup to the man-hoist, underground ventilation system, water pumping and essential services in the plant.

A 10 kV substation within the mining area provides power service for the entire mining area. The power supply and distribution in the process plant, mining area, administrative and living areas are configured based on needs.

Sewage treatment and water treatment plants operate at the mine site. Any water that is not recycled and is released to the environment is treated to comply with standing regulations.

Underground water is discharged to surface using conventional centrifugal pumps via pipe-lines installed in the Ramp, Ramp Shaft, and Main Shaft. Underground water pumped to surface is collected in ponds at the Ramp portal or Main Shaft for sediment settling prior to being pumped to the process plant water treatment station. In 2017, a total volume of 468,630 m³ of underground water was treated, including 268,844 m³ discharged and 199,786 m³ recycled.

There is a comprehensive repair workshop on surface for the maintenance of large-scale production equipment, vehicle repair, processing and repair of partial components, and the processing of emergency parts. It has the following services: tyre processing, maintenance, and servicing, welding, electrical, hydraulic, tools, parts, and material warehouse. In addition, the mining contractor has its own mobile equipment surface workshop for repairs and servicing located adjacent to the Ramp portal.

There are also underground workshop facilities that are composed of mining equipment maintenance workshop, equipment and spare parts store, dump oil depot, reserve electric locomotives, and tramcars maintenance workshop and stockpile yard.

The explosives warehouse was constructed in the valley to the southeast of the GC Mining Area.

A properly constructed containment for storage of fuel is located in the vicinity of the diesel generators and fuel dispensing facilities.

There is a mine dry facility near the portal accommodating lockers, change room, showers, and washrooms for the miners. The mine office complex is for administration and engineering functions and to provide working space for management, supervision, geology, engineering and other operations support staff.

Silvercorp operates the mine using contractors for development and production. The operation and maintenance of Silvercorp's fixed plant is via Silvercorp personnel. Silvercorp provides its own management, technical services, and supervision staff to manage the GC mine operation.

Concentrate contracts

Sales contracts are in place for lead concentrates with Shandong Humon Smelting Co. Ltd., and for zinc concentrates with Chenzhou Qiantai Industrial Co. Ltd. and Henan Yuguang Zinc Industry Co. Ltd. All contracts have an effective period of one year, with key elements of the contracts subject to change based on market conditions when monthly supplemental agreements to the annual contracts are negotiated. Arsenic levels in the concentrates are acceptable to the Chinese smelters. All contracts have freight and related expenses to be paid by the customers.

Environment

Silvercorp has all the required permits for its operations on the GC Property and, in conjunction with safety and environmental certificates, these give Silvercorp the right to carry out full mining and mineral processing operations.

An Environmental Impact Assessment (EIA) report on the GC Project was prepared by the Guangdong Environmental Technology Centre (GETC) initially, and then reassessment is done periodically as required by regulations. An Environmental Permit was issued by the Department of Environmental Protection of Guangdong Province in June 2010.

There are no cultural minority groups within the general area surrounding the project. No records of cultural heritage sites exist within or near the GC project areas. The surrounding land is used predominantly for agriculture. The mining area does not cover any natural conservation, ecological forests or strict land control zones.

Silvercorp has made a range of cash donations and contributions to local capital projects and community support programs, sponsoring university students and undertaking projects such as village road construction, and school upgrading and construction. Silvercorp has also made economic contributions to the local economy in the form of direct hiring and retention of local contractors, suppliers, and service providers.

A monitoring plan has been negotiated between the company and the local environmental protection department to meet the environmental management requirements of the project. Key components of the monitoring plan are water pollution monitoring, together with environmental air and noise monitoring. The monitoring work is carried out by qualified persons and / or a third party contractor and is undertaken on a regular basis.

Costs and economics

Cost estimates are in U.S. dollars and assume an exchange rate of 6.5 RMB to US\$1. The FY2019 budget is based on mining and milling 250,000 tonnes of ore, of which 97% would be by shrinkage and 3% by resuing. Other major operational requirements budgeted are waste development at 4,479 m, exploration tunneling at 11,060 m, and drilling at 30,000 m. Sustaining development of 673 m is also budgeted.

All major infrastructure for operation of the Gaocheng mine is in place, including that for the potential production rate increase to 1,600 tpd. Sustaining capital costs are budgeted for mine development tunneling and for property, plant and equipment and come to a total of \$810,000 for FY2019, or \$3.24 per tonne mined.

Mining operating costs are categorized by direct mining (shrinkage or resuing), waste development, exploration tunnelling, drilling, and common costs. Other budgeted operating costs are for milling, general and administrative items, and government fee, Mineral Resources tax, and other taxes. The operating cost breakdown for the FY2019 budget is as follows: mining - \$42.08/tonne, milling - \$16.78/tonne, G&A - \$7.66/tonne, mineral resources tax, etc. - \$7.43/tonne, for a total budget operating cost of \$73.95/tonne.

Contractor costs are the major component of the mining cost. The principal components of the milling costs are utilities (power and water), consumables (grinding steel and reagents), and labour.

The Gaocheng mine has been in commercial production for four years. From FY2019 onwards, a 12-year LOM is envisaged for the resource as currently understood, with average silver equivalent grades projected to be of the order of 335 g/t for the first eight years and then to fall to an average of 240 g/t for the remainder of the mine life.

A base case NPV at 8% discount rate of \$160M (pre-tax), \$120M (post-tax) is projected for the 12-year LOM.

Interpretation and conclusions

Polymetallic mineralization at the GC project comprises over 80 distinct veins, ranging in thickness from a few centimetres to several metres, with a general east-west orientation and dipping generally south at 60° – 80°. The Mineral Resource estimates described in the report were prepared by Silvercorp using Micromine software and reviewed, classified and signed off by Ms D. Nussipakynova, P.Geo of AMC, who is a Qualified Person for the purposes of the Technical Report.

Using a 100 g/t silver equivalent (AgEq) cut-off grade, Measured and Indicated Resources (inclusive of Mineral Reserves) are estimated at 6.37 million tonnes grading 96 g/t silver (Ag), 1.3% lead (Pb), and 2.9% zinc (Zn); and Inferred Mineral Resources are estimated at 7.48 million tonnes grading 107 g/t Ag, 1.2% Pb, and 2.6% Zn.

Compared to the previous estimate of Mineral Resources (Technical Report effective date 23 January 2012 – the '2012 Technical Report') Measured and Indicated Resources have decreased by 16%, which is a combination of mining depletion and change in classification method. Inferred Mineral Resources have decreased by 6%. In the Measured category the silver grade has decreased by 56% and lead and zinc grades have decreased by 1% and 3% respectively. In the Indicated category silver grades have increased by 18%, and lead and zinc grades have decreased by 7% and 12% respectively. In the Inferred category, grades have decreased for silver, lead, and zinc by 13%, 16%, and 2% respectively.

The results of the underground drilling program at GC show that vein structures are still open at depth.

Silvercorp has implemented industry standard practises for sample preparation, security and analysis. This has included common industry QA/QC procedures to monitor the quality of the assay database, including inserting Certified Reference Material (CRM) samples, blank samples and coarse (uncrushed) sample duplicates into sample batches on a predetermined frequency basis. Umpire check duplicates samples have been submitted to check laboratories to confirm analytical accuracy.

AMC's review of Silvercorp's QA/QC procedures has highlighted a number of issues that require further investigation and improvement. AMC and Silvercorp have discussed these issues and agreed on a process to address and improve QA/QC, the recommendations for which are itemized in Section 26. AMC does not consider these issues to have a material impact on the global Mineral Resources and Mineral Reserve estimates but believes that there could be material impacts on a local scale. Overall, it considers the assay database to be acceptable for Mineral Resource estimation.

Mineral Reserves have been estimated using a full breakeven cut-off grade of 180 g/t AgEq for shrinkage stoping (245 g/t AgEq for the projected smaller amount of resuing), based on a mine

design and plan prepared by Silvercorp engineers and reviewed by Mr H. Smith, P.Eng. of AMC, who is a Qualified Person for the purposes of the Technical Report. Total Proven and Probable Reserves are 3.56 million tonnes grading 96 g/t silver, 1.4% lead, and 3.1% zinc, containing 11 million ounces silver, 112 million pounds lead, and 240 million pounds zinc.

Metal prices used in determining cut-off grades for both Mineral Resources and Mineral Reserves are: silver - \$19/troy ounce; lead - \$1.00/lb; zinc - \$1.25/lb. An exchange rate of 6.5 RMB : US\$1 and mining costs of \$37/t for shrinkage and \$65/t for resuing have been assumed. Metallurgical recovery assumptions are: silver - 77%; lead - 86%, zinc - 83%.

In comparison with the Mineral Reserve estimate in the 2012 Technical Report, there is a 264% increase in Proven Mineral Reserve tonnes and a 56% decrease in Probable Mineral Reserve tonnes, resulting in a decrease in total Mineral Reserve tonnes of 25% (1,186,000 tonnes). Silvercorp received a mining permit in December 2010. From the start of commercial operations at Gaocheng in 2014 through to 31 December 2017, 988,000 tonnes have been mined at average head grades of 98 g/t silver, 1.5% lead, and 2.7% zinc.

The predominant shrinkage mining method uses the blasted ore as the working platform for each stope lift. The ore is removed on completion of stope mining leaving an empty void. There is potential to opportunistically dispose of development waste into these voids, but current mine plans do not include this approach. The resue method uses blasted waste from the footwall as the working platform for each stope lift. The waste remains in the stope at completion of stope mining. Some hand sorting of ore from waste is conducted.

The rock mass condition is categorized as Fair to Good. AMC's previous assessment anticipated that the vein and host rocks in the mine area would generally be competent and require minimal ground support. This has largely been confirmed in operations, with most areas deemed to require little or no support. Where Poor ground conditions have been encountered, ground support is provided, with a range of strategies available depending on the local situation.

Based on Proven and Probable Reserves only, the GC mine is a viable operation with a projected Life of Mine (LOM) of 12 years through to 2030, with an average annual production rate of approximately 300,000 tonnes, and with average silver equivalent grades of the order of 335 g/t for the first eight years and then 240 g/t for the remainder of the mine life. GC also has the potential to extend the LOM beyond 2030, via conversion of existing Mineral Resources to Mineral Reserves, and further exploration and development.

Since the start of trial operations in 2013 and commercial production in 2014 (FY2015), lead and zinc concentrates have been produced in commercial quantities at the GC processing plant. Small amounts of tin concentrate and sulphur have also been produced but these quantities have not been significant enough to be material to mine economics. In all sections of the plant, space / capacity has been allocated for an expansion to 1,600 tpd, but such expansion is not contemplated at this time.

Sales contracts are in place for the lead concentrates with Shandong Humon Smelting Co. Ltd., and for the zinc concentrate with Chenzhou Qiantai Industrial Co. Ltd. and Henan Yuguang Zinc Industry Co. Ltd. All contracts have an effective period of one year, with key elements of the contracts subject to change based on market conditions when monthly supplemental agreements to the annual contracts are negotiated. All contracts have freight and related expenses to be paid by the customers.

In the 2012 Technical Report, AMC expressed some concerns about potential arsenic (As) levels in concentrates. Experience reported in operations indicates that the As level in the zinc concentrate has been maintained below 1% with, in most instances, a similar result for the pyrite concentrate. The GC lead and zinc concentrates are acceptable to the smelters with which Silvercorp has current contracts (see Section 13.5).

All pertinent facilities are in place at the GC site, inclusive of security, accommodation, catering, engineering and administration building, mine dry, mine ventilation, main power sub-station, mine rescue, water supply, compressed air, underground dewatering, sewage treatment, explosives magazines, water treatment plant, maintenance / repair facilities, storage, laboratory, communications, fuel farm, fire prevention, waste rock dump, and tailings management facility (TMF).

With respect to waste rock, all such material brought to surface is either used by Silvercorp for construction / maintenance activities or is removed from the site, free of charge, by local persons, again as construction material. The environmental assessment has indicated that waste rock at the GC mine has no significant acid-generating potential.

The TMF utilizes dry stacking and filling (from bottom to top and stacking by bench to form the embankment) with concurrent rolling and compaction. In the 2012 Technical Report AMC recommended that the TMF safety analysis be re-assessed in accordance with industry practice. The most recent TMF risk assessment report was approved by the Chinese authorities on 14 May 2018 and the TMF Safety Production Certificate was renewed on 4 September 2017. That notwithstanding, AMC has recommended that Silvercorp continues to satisfy itself, as per best industry practice, that all fundamental aspects of the TMF design, construction and operation have been and continue to be satisfactorily addressed. This may include geotechnical drilling of the dam foundation area, as it is AMC's understanding that such activity has not specifically been undertaken.

Silvercorp utilizes contract labour for mining at GC on a rate per tonne or a rate per metre basis. The contract includes all labour, all fixed and mobile equipment, materials, and consumables, including fuel and explosives, which are purchased through the company. Ground support consumables such as timber and power are the responsibility of the company.

The FY2019 budget is based on mining and milling 250,000 tonnes of ore, of which 97% would be by shrinkage and 3% by resuing. Other major operational requirements budgeted are waste development at 4,479 m, exploration tunneling at 11,060 m, and drilling at 30,000 m. Sustaining development of 673 m is also budgeted. Cost estimates are in U.S. dollars and assume an exchange rate of 6.5 RMB to US\$1.

FY2019 sustaining capital is budgeted at \$810,000, which equates to \$3.24 per tonne of ore projected to be mined.

Based on the LOM production forecast and projected mining costs, and assuming long-term metal prices to be the same as those used for cut-off grade determination (silver - \$19/troy ounce; lead - \$1.00/lb; zinc - \$1.25/lb), a simple economic model analysis indicates a pre-tax NPV at 8% discount rate of \$160M (\$120M post-tax). Over the LOM, 45% of the net revenue is projected to come from zinc, 35% from silver, and 20% from lead.

As part of an economic sensitivity assessment, metal prices more in line with those current at the time of writing of this Technical Report (silver - \$16.75/troy ounce, lead - \$1.14/lb, zinc - \$1.45/lb) were used in the simple economic model, resulting in a projected pre-tax NPV at 8% discount rate of \$176 M (\$132 M post-tax). For this scenario, 49% of the net revenue is projected to come from zinc, 29% from silver, and 22% from lead.

Recommendations

AMC makes the following recommendations for the GC mine:

AMC's review of Silvercorp's QA/QC procedures has highlighted a number of issues that require further investigation and improvement. AMC and Silvercorp have discussed these issues and agreed on a process to address and improve QA/QC via an overhaul of the CRM program as follows:

- Purchase five additional commercially-produced CRMs, one high grade, two at around the cut-off grade of the deposit and two at around the expected grade of the deposit (note that having CRMs with similar, but slightly different values, reduces the chances of the laboratory recognizing them).
- If Silvercorp intends to keep using CRM GSO-2, require the Institute of Geophysical and Geochemical Exploration to provide the standard deviation data.
- Introduce real-time monitoring of CRM results on a batch by batch basis.
- Re-assay sample batches with two consecutive CRMs occurring outside two standard deviations, or one CRM occurring outside three standard deviations.
- Increase insertion rates to at least 5%.
- Investigate the consistent negative biases apparent in the lead and zinc assays for CDN-FCM-7, to determine if they indicate real negative biases for the corresponding sample batches or arise from the GC lab recognizing the CRMs and assuming incorrect certified values.
- Assay the source of the blank material to ensure its suitability as a blank.
- Substantially reduce Silvercorp's pass / fail criteria on blanks to conform with common industry practice.
- Investigate the very marked differences in performance between the ALS and GC labs and seek reassurance from the GC lab that it is using the blanks in a manner consistent with good industry practice.
- Increase blank insertion rates to at least 4% of samples submitted. Insert blanks immediately after expected high grade mineralization.
- Monitor blanks immediately upon receipt of results and have batches re-analysed if significant contamination is indicated.
- Consider the introduction of crushed duplicates and pulp duplicates (replicates) as part of the GC QA/QC program to improve monitoring of sample preparation and assaying performance.
- Conduct sieve analyses at various stages of sample preparation at the laboratory to ensure optimal parameters are achieved and minimal sampling errors are introduced.
- Increase umpire sample submission rates to around 5% for both drillhole and underground samples.
- Modify the central database so that assay data be recorded without rounding to accurately reflect the original assay certificates.
- Internally validate the existing sample database to ensure that any other sample prefix issues are addressed.
- Review database and sample procedures to ensure that sample prefix issues do not reoccur.

There are a number of recommendations with respect to Mineral Resource estimation:

- Collect additional bulk density samples to represent various ore types including low grade, medium grade, high grade, and waste material.
- Use of a dynamic anisotropy search or increase the search radius of the ellipse across the veins, to improve grade continuity within the estimation.
- Continue to use the revised AMC approach to Mineral Resource classification, which is based on estimation criteria and manual adjustments where appropriate. This eliminates outliers.
- Undertake future modelling of the GC deposit as a single block model as opposed to individual block models for each vein.

Further recommendations in the Technical Report are:

- For bulk density assessment and verification, collect additional samples to represent various mineralization types including low grade, medium grade, high grade and waste material.
- Assess ground conditions on a round by round basis in all development headings (ore and waste) to determine the requirement for ground support. Doing so will help prevent the occurrence of significant failures from backs and walls, which require timely rehabilitation and expose the work force to rock-fall hazard.
- Ensure scaling of the development heading on a round by round basis.
- Maintain a focus on dilution and grade control.
- Conduct routine check scaling of all unsupported development at the mine. This process can help identify areas of the mine in which rock mass deterioration is occurring and allow rehabilitation works to be planned.
- Where possible, avoid mining development intersections in fault zones, and design drifts to cross fault zones at right angles (to minimize the exposure length within the drift).
- Assess specific rock mass conditions for critical underground infrastructure, including shafts and chambers, to determine ground support requirements to ensure serviceability of the excavation for the life of mine.
- Ensure that an assessment of crown pillar requirements has been incorporated into the detailed mine design with particular focus on surface pillar requirements in the vicinity of Hashui Creek valley, and any other streams (or drainage paths) that traverse the mine area.
- As part of ongoing operations at the mine, continuously review geotechnical and ground support aspects in a formal and recordable manner, bearing in mind previous recommendations, local and mine-wide operating experience in all rock types encountered, any advisable data collection, and also looking to future mining development.
- With respect to the TMF, Silvercorp to continue to satisfy itself, as per best industry practice, that all fundamental aspects of the TMF design, construction and operation have been and continue to be satisfactorily addressed. This may include geotechnical drilling of the dam foundation area, as it is AMC's understanding that such activity has not specifically been undertaken.
- Continue with a focus on safety improvement, including implementation of a policy where the more stringent of either Chinese or Canadian safety standards are employed.
- Place a strong focus on stockpiling and record keeping procedures and ensure that the summation of individual ore car weights by stope and zone is, as far as practicable, fully integrated into the tracking and reconciliation process.
- Undertake periodic mill audits aimed at ensuring optimum process control and mill performance.

- Continue exploration tunnelling and diamond drilling at Gaocheng. The exploration tunnelling is used to upgrade the drill-defined Resources to the Measured category, and the diamond drilling is used to expand and upgrade the previous drill-defined Resources; explore for new mineralized zones within the unexplored portions of vein structures, and test for extensions of the vein structures.

Contents

1	Summary	ii
2	Introduction.....	26
3	Reliance on other experts	28
4	Property description and location.....	29
	4.1 Exploration and mining permits	30
5	Accessibility, climate, local resources, infrastructure, and physiography	32
6	History	33
	6.1 History of mining	34
	6.2 History of Mineral Resources	35
7	Geological setting and mineralization	37
	7.1 Regional geology	37
	7.2 Property geology	38
	7.2.1 Structures.....	40
	7.3 Mineralization.....	42
	7.4 Characteristics of the mineralized veins	42
	7.5 Other mineralization features	44
8	Deposit types.....	45
9	Exploration	46
	9.1 Soil geochemical program.....	46
	9.2 Topographic and geological mapping	47
	9.3 Trenching and pitting	47
	9.4 Underground works.....	49
10	Drilling	54
	10.1 Historic drilling (pre-2008).....	54
	10.2 Silvercorp drilling (2008 – 2017)	54
	10.2.1 2008 drill program	55
	10.2.2 2011 to 2017 drill programs	56
	10.2.3 Bulk density	64
	10.3 Conclusion	65
11	Sample preparation, analyses, and security	66
	11.1 Introduction.....	66
	11.2 Sampling methods	66
	11.2.1 Drillhole sampling	66
	11.3 Underground sampling	66
	11.4 Sample shipment and security.....	67
	11.5 Sample preparation and analysis	67
	11.5.1 ALS Chemex Guangzhou.....	67
	11.5.2 Gaocheng Mine Laboratory	67
	11.6 Data management	68
	11.7 QA/QC monitoring program – overview	68
	11.8 Certified reference materials	70
	11.8.1 Description.....	70
	11.8.2 AMC discussion	70
	11.8.3 AMC conclusions	75
	11.8.4 AMC recommendations	76
	11.9 Blank samples.....	76
	11.9.1 Description.....	76

11.9.2	AMC discussion	77
11.9.3	AMC conclusions	79
11.9.4	AMC recommendations	79
11.10	Coarse duplicate samples.....	79
11.10.1	Description.....	79
11.10.2	AMC discussion	81
11.10.3	AMC conclusions	82
11.10.4	AMC recommendations	82
11.11	Umpire (check lab) duplicate samples	82
11.11.1	Description.....	82
11.11.2	AMC discussion	84
11.11.3	AMC conclusions	84
11.11.4	AMC recommendations	84
11.12	Conclusions.....	84
11.13	Recommendations	85
12	Data verification	86
12.1	Site visit.....	86
12.2	Assay data verification	86
12.3	Data validation	86
12.4	AMC discussion.....	86
12.5	Recommendations	87
12.6	Conclusions.....	87
13	Mineral processing and metallurgical testing	88
13.1	Introduction	88
13.2	Metallurgical samples	88
13.3	Mineralogy.....	89
13.4	Metallurgical testwork	90
13.4.1	Lead flotation conditions	90
13.4.2	Zinc and pyrite flotation conditions.....	91
13.4.3	Sulphide circuit flotation tests.....	91
13.4.4	Copper-lead separation tests	93
13.4.5	Tin recovery tests	93
13.4.6	Optimization opportunities	93
13.5	Concentrate quality considerations.....	95
13.6	Summary of testwork outcomes	96
13.6.1	Metallurgical samples	96
13.6.2	Mineralogy	96
13.6.3	Laboratory testwork	96
13.6.3.1	Grinding.....	96
13.6.3.2	Flotation	96
13.6.3.3	Tin recovery	96
13.6.4	Optimization opportunities	97
13.6.5	Concentrate quality	97
13.7	Mill operation FY2015 to present.....	97
14	Mineral Resource estimates.....	99
14.1	Introduction	99
14.2	Data used	99
14.2.1	Drillhole database	99
14.2.2	Bulk density	101
14.3	Domain modelling.....	101
14.3.1	Lithological and mineralization domains	101
14.4	Statistics, capping, and compositing.....	102
14.5	Block model	106

14.5.1	Block model parameters	106
14.5.2	Grade estimation	107
14.5.3	Mining depletion	108
14.5.4	Resource classification	109
14.5.5	Block model validation	111
14.5.6	Mineral Resource reporting	117
14.6	Comparison with previous Mineral Resource estimate	121
14.7	Recommendations	123
15	Mineral Reserve estimates	124
15.1	Introduction and Mineral Resources base	124
15.2	Mineral Reserve estimation methodology	124
15.3	Cut-off grades	124
15.3.1	AMC comment on cut-off grades	125
15.4	Bulk density	125
15.5	Dilution and recovery factors	125
15.5.1	Dilution	125
15.5.2	Mining recovery factors	126
15.6	Mineral Reserve estimate	126
15.7	Conversion of Mineral Resources to Reserves	127
15.8	Comparison of 2018 and 2012 Mineral Reserve estimates	127
16	Mining methods	129
16.1	Conventions	129
16.2	Introduction	129
16.3	Geotechnical conditions	129
16.3.1	Introduction	129
16.3.2	Available data	130
16.3.3	Data analysis	131
16.3.4	Characterization of geotechnical conditions	133
16.3.5	In situ stress	134
16.3.6	Hydrogeology	134
16.3.7	Mine design considerations	134
16.3.7.1	Rock mass conditions	134
16.3.7.2	Surface requirements	135
16.3.7.3	Stability assessment for stoping	135
16.3.7.4	Stope pillars	136
16.3.7.5	Main shaft pillar	136
16.3.7.6	Ground support requirements	136
16.3.7.7	Conclusions	137
16.4	Extraction sequence	138
16.5	Production rate	138
16.6	Mining methods	138
16.6.1	Shrinkage stoping	138
16.6.2	Resue stoping	139
16.6.3	Resue management and grade control	141
16.7	Mine design	141
16.7.1	Pre-existing development	143
16.7.2	Mine access	144
16.8	Mine development	145
16.8.1	Development requirement	145
16.8.2	Shafts	146
16.9	Mine production	147
16.9.1	Commercial production to end-2017	147
16.9.2	LOM plan production	147

16.10	Rock handling	149
16.10.1	Shaft hoisting	149
16.10.2	Waste material	150
16.11	Mine services	151
16.11.1	Ventilation	151
16.11.1.1	Primary ventilation	151
16.11.1.2	Secondary ventilation	152
16.11.2	Water supply	152
16.11.3	Dewatering	152
16.11.4	Power supply	153
16.11.5	Fuel storage and dispensing	154
16.11.6	Compressed air	154
16.11.7	Communications	154
16.11.8	Explosives storage	154
16.11.9	Mine equipment maintenance	154
16.12	Mine equipment details	155
16.12.1	Equipment productivities	156
16.13	Mine personnel	156
16.14	Mine safety	157
16.14.1	Fire prevention	158
16.14.2	Mine rescue	158
16.14.3	Dust	158
16.14.4	Emergency egress	158
16.14.5	Mine refuge stations	159
16.14.6	Ablutions	159
17	Recovery methods	160
17.1	Introduction	160
17.2	Process flowsheet	160
17.3	Process description	161
17.3.1	Summary	161
17.3.2	Crushing	163
17.3.3	Grinding	163
17.3.4	Flotation	164
17.3.5	Concentrate handling	166
17.3.6	Tin recovery circuit	166
17.4	Process control and automation	167
17.5	Ancillary facilities	168
17.5.1	Laboratory	168
17.5.2	Maintenance workshop(s)	168
17.6	Key inputs	169
17.6.1	Power	169
17.6.2	Water	169
17.6.3	Reagents	169
17.7	Summary	169
18	Project infrastructure	171
18.1	Tailings Management Facility (TMF)	171
18.1.1	Overview	171
18.1.2	Site selection	171
18.1.3	TMF design and assessment	173
18.1.4	Tailings delivery	176
18.2	Waste rock dump	176
18.3	Power supply	177
18.4	Roads	178

18.5	Transportation.....	178
18.6	Water supply.....	178
18.7	Sewage treatment	178
18.8	Mine dewatering	178
18.9	Water treatment facility.....	178
18.10	Site communications	179
18.11	Camp	179
18.12	Dams and tunnels.....	180
	18.12.1 Surface maintenance workshop	180
18.13	Explosives magazines.....	180
18.14	Fuel farm.....	181
18.15	Mine dry.....	181
18.16	Administration building.....	181
18.17	Assay laboratory.....	181
18.18	Security / gatehouse	181
19	Market studies and contracts.....	182
19.1	Concentrate marketing	182
19.2	Smelter contracts	182
19.3	Commodity prices	183
20	Environmental studies, permitting, and social or community impact.....	184
20.1	Introduction	184
20.2	Laws and regulations	185
	20.2.1 Regulation guidelines	185
20.3	Waste and tailings disposal management.....	186
20.4	Site monitoring.....	186
	20.4.1 Monitoring plan.....	186
	20.4.2 Water management.....	187
	20.4.3 Groundwater	188
	20.4.4 Waste water.....	188
	20.4.5 Gas emission monitoring.....	190
	20.4.6 Noise monitoring.....	191
	20.4.7 Soil testing.....	191
20.5	Permitting requirements	192
20.6	Social and community interaction	193
	20.6.1 Cultural minorities and heritages	193
	20.6.2 Relationships with local government	193
	20.6.3 Labour practices	193
20.7	Remediation and reclamation	194
20.8	Site closure plan.....	194
21	Capital and operating costs.....	195
21.1	Key cost parameters	195
21.2	Capital costs	195
	21.2.1 Sustaining capital.....	195
21.3	Operating costs	195
22	Economic analysis.....	198
22.1	Introduction	198
22.2	Annual production schedule	198
22.3	Cash flow forecast	199
22.4	Sensitivity analysis	201
23	Adjacent properties.....	202
24	Other relevant data and information	203

25	Interpretation and conclusions	204
26	Recommendations	207
27	References.....	209
28	QP Certificates	211

Tables

Table 1.1	Summary of Mineral Resources as of 31 December 2017	vi
Table 1.2	Gaocheng mine Mineral Reserves estimate at 31 December 2017	vii
Table 2.1	Persons who prepared or contributed to this Technical Report	26
Table 4.1	Mining Permit Corner Points of the GC Property	30
Table 4.2	GC Mining Permit, owned by Guangdong Found	31
Table 6.1	Historical exploration work 2001 – 2008	34
Table 6.2	Record of drilling 2001 – 2008.....	34
Table 6.3	Details of historical underground workings	35
Table 6.4	SRK April 2008 Mineral Resource estimates for the GC Project.....	36
Table 6.5	AMC June 2009 Mineral Resource estimates for the GC Project	36
Table 6.6	AMC January 2012 Mineral Resource estimates for the GC Project.....	36
Table 7.1	Dimensions and occurrences of selected mineralized veins.....	43
Table 9.1	Surface exploration programs completed in 2008.....	46
Table 9.2	Trenches and pits completed by Silvercorp in 2008 with vein highlights.....	48
Table 9.3	Summaries of underground works between 2012 and 2017.....	49
Table 9.4	Underground tunnelling program – mineralization highlights	52
Table 10.1	Meters of various drill core sizes prior to acquisition by Silvercorp.....	54
Table 10.2	Drilling programs between 2011 and 2017	57
Table 10.3	Drillhole intersections >100 g/t AgEq by vein	59
Table 10.4	Drillhole intersections highlighted on Figure 10.5	62
Table 11.1	ALS Chemex lab method and detection limits	67
Table 11.2	Silvercorp GC lab detection limits.....	68
Table 11.3	QA/QC statistics	69
Table 11.4	QA/QC insertion rates	69
Table 11.5	GC Certified Reference Materials.....	70
Table 11.6	AMC CRM review statistics (all elements combined, 2011 – 2017).....	72
Table 11.7	Silvercorp blank statistics	77
Table 11.8	Assay results for blank samples (ALS Chemex Guangzhou)	77
Table 11.9	Assay results for blank material (Gaocheng)	77
Table 11.10	Summary of RPD plots for Ag, Pb, and Zn for coarse duplicate samples	81
Table 11.11	Coarse duplicate sample statistics.....	81
Table 11.12	Details of check assays.....	82
Table 11.13	Results of umpire laboratory duplicates for drillhole samples	84
Table 12.1	Data verification results.....	86
Table 13.1	Metallurgical samples relative to 2012 Mineral Reserve and FY2015 / 2018 mill head grades	89
Table 13.2	Silver associations	89

Table 13.3	Closed circuit flotation test results	93
Table 13.4	Closed circuit flotation test results	96
Table 14.1	Summary of Mineral Resources as of 31 December 2017	99
Table 14.2	Summary of data used in 2018 estimation	100
Table 14.3	Grade capping summary	103
Table 14.4	Statistics of raw, capped, and composited assay data for the selected 10 veins	105
Table 14.5	Block models rotation angles	107
Table 14.6	Micromine search parameters	108
Table 14.7	Statistical comparison of composites and block model for the 10 largest veins	112
Table 14.8	Input parameters in calculating Mineral Resource cut-off grade	117
Table 14.9	Mineral Resources as of 31 December 2017 by each vein at 100 g/t silver equivalent	118
Table 14.10	Reporting from AMC block models at a range of cut-off values	121
Table 14.11	Comparison of Mineral Resources at 100 g/t AgEq cut-off grade	122
Table 15.1	Mineral Reserve cut-off grades and key estimation parameters	125
Table 15.2	Average dilution by mining method	126
Table 15.3	Gaocheng mine Mineral Reserve estimate at 31 December 2017	127
Table 15.4	Resources and Reserves comparison	127
Table 15.5	Comparison of 2018 and 2012 Mineral Reserve estimates	128
Table 16.1	Rock mass classification parameters by geotechnical domain	134
Table 16.2	Co-ordinates of pre-existing development, Main Shaft, and RARs	144
Table 16.3	Vertical development profiles and categories	145
Table 16.4	Development waste	146
Table 16.5	Mine shafts	147
Table 16.6	GC production FY2015 – FY2018	147
Table 16.7	LOM production summary	148
Table 16.8	Underground water pumped, discharged, and recycled for year 2017	153
Table 16.9	Mining contractor typical key equipment summary	155
Table 16.10	Silvercorp fixed plant summary	156
Table 16.11	Development and production activity productivities	156
Table 18.1	Key metrics of design and latest assessment	174
Table 19.1	Key elements of smelter contracts	183
Table 20.1	Water environmental monitoring plan for the Gaocheng mining area	187
Table 20.2	Ground water testing results at Gaocheng village (1)	188
Table 20.3	Ground water testing results at Gaocheng village (2)	188
Table 20.4	Waste water monitoring results. Guangzhou Najia Testing Technology Ltd. Report No. GZNJIA20170176	189
Table 20.5	Tailing water monitoring results – Guangzhou Najia Testing Technology Ltd. Report No. NJA170717001	190
Table 20.6	Exhaust gas monitoring results – Screening workshop. Guangzhou Najia Testing Technology Ltd. Report No. GZNJIA20170176	190
Table 20.7	Exhaust gas monitoring results – Crushing workshop. Guangzhou Najia Testing Technology Ltd. Report No. GZNJIA20170176	191

Table 20.8	Noise monitoring results - Guangzhou Najia Testing Technology Ltd. Report No. GZNJIA20170176	191
Table 20.9	Soil testing result.....	192
Table 20.10	Expenditures on reclamation and remediation from 2012 to 2017 ('000 RMB)	194
Table 21.1	Gaocheng sustaining capital budget FY2019	195
Table 21.2	Gaocheng operating cost budget 2019*	196
Table 22.1	Gaocheng LOM production schedule	199
Table 22.2	Gaocheng mine cash flow projection	200
Table 22.3	Gaocheng mine sensitivity analysis	201

Figures

Figure 4.1	GC property location map	29
Figure 7.1	Tectonic geology map of southern China.....	37
Figure 7.2	Regional geological map	38
Figure 7.3	Property geology map	39
Figure 7.4	The occurrence and distribution of mineralized veins (Level -100 m)	40
Figure 7.5	Cross section of Exploration Line 22A	41
Figure 7.6	Fault planes	42
Figure 9.1	Soil geochemical anomalies of Ag, Pb, and Zn on the GC Property	47
Figure 9.2	Trenches and pits on the GC Property.....	48
Figure 9.3	Longitudinal projection of vein V2E	50
Figure 10.1	Drill core storage facility	55
Figure 10.2	Drilling completed on the GC Property	56
Figure 10.3	Underground drillhole plan at Level 0 m.....	58
Figure 10.4	Cross section on Exploration Line 22A	60
Figure 10.5	Inset map for Cross Section 22A.....	61
Figure 10.6	Cross section on Exploration Line 34	63
Figure 10.7	Longitudinal section of Vein 2E	64
Figure 11.1	Control chart for GSO-2, Ag, drillhole samples.....	73
Figure 11.2	Control chart for GSO-2, Pb, drillhole samples.....	73
Figure 11.3	Control chart for GSO-2, Zn, drillhole samples.....	74
Figure 11.4	Control chart for CDN-FCM-7, Ag, drillhole samples.....	74
Figure 11.5	Control chart for CDN-FCM-7, Pb, drillhole samples.....	75
Figure 11.6	Control chart for CDN-FCM-7, Zn, drillhole samples.....	75
Figure 11.7	2011 – 2017 blank performance (Pb)	78
Figure 11.8	2011 – 2017 blank performance (Pb)	78
Figure 11.9	Scatter chart showing results of coarse duplicate samples, 2011 – 2017.....	80
Figure 11.10	Scatter charts showing results of umpire duplicate samples	83
Figure 13.1	Closed circuit flotation test flowsheet	92
Figure 13.2	Concentrate value vs % Pb (Ag \$18/oz)	94
Figure 13.3	Concentrate value vs % Pb (Ag \$30/oz)	95
Figure 14.1	3D view of GC drillholes and channels sampling.....	100
Figure 14.2	Plan view of mineralization domains.....	101
Figure 14.3	Pie chart of 89 veins by classified tonnes	102

Figure 14.4	Mining depletion longitudinal project vein V2E	108
Figure 14.5	Plan view of mined out stope (purple) and written-off shapes (yellow)	109
Figure 14.6	Mineral Resource classification vertical section: vein NV10	110
Figure 14.7	Silver equivalent grades vertical section: vein NV10	111
Figure 14.8	Swath-plot of silver grades in Measured and Indicated blocks of vein NV10....	114
Figure 14.9	Swath-plot of lead grades in Measured and Indicated blocks of vein NV10	115
Figure 14.10	Swath-plot of zinc grades in Measured and Indicated blocks of vein NV10	116
Figure 14.11	Vertical section of vein V2E models coloured by silver grades	117
Figure 16.1	Section looking west at 93500 mE, showing '100-RQD' histograms plotted on drillhole traces.....	131
Figure 16.2	Distribution analysis for all geotechnical logging data	132
Figure 16.3	RQD data distribution	133
Figure 16.4	Typical shrinkage stope layout.....	139
Figure 16.5	Typical resue stope layout	140
Figure 16.6	GC Mine design	142
Figure 16.7	GC veins and development plan at – 150 mRL.....	143
Figure 16.8	Development profile by type	146
Figure 16.9	LOM production profile by type	149
Figure 16.10	Main Shaft headframe	150
Figure 16.11	GC Mine operations labour	157
Figure 17.1	Process flowsheet	161
Figure 17.2	Processing plant site plan	162
Figure 17.3	Surface grizzly feed to ROM ore bin.....	163
Figure 17.4	Grinding mills and spiral classifier	164
Figure 17.5	Grinding / flotation plant general arrangement	165
Figure 17.6	Flotation cells.....	166
Figure 17.7	Disc filters and zinc concentrate shed	166
Figure 17.8	Control room screens	167
Figure 17.9	Laboratory	168
Figure 18.1	Plan of surface facilities, GC Project	172
Figure 18.2	Satellite aerial view of surface facilities, GC Project	173
Figure 18.3	GC TMF dam and water seepage.....	174
Figure 18.4	TMF dam water catchment	175
Figure 18.5	GC mine substation.....	177
Figure 18.6	GC water treatment facility	179
Figure 23.1	Zonation of mineralization in the Daganshan mineralization field	202

2 Introduction

AMC Mining Consultants (Canada) Ltd. (AMC) was commissioned by Silvercorp Metals Inc. (Silvercorp) to prepare an independent Technical Report (the 2018 Technical Report) on the Gaocheng (GC) property, located in Gaocun Township, Yun'an County, Guangdong Province, China. AMC has prepared previous Technical Reports on the GC property in 2009 ('NI 43-101 Technical Report Update on the GC Ag-Zn-Pb Project in Guangdong Province, People's Republic of China', effective date 18 June 2009), and 2012 ('NI 43-101 Technical Report on the GC Ag-Zn-Pb Project in Guangdong Province, People's Republic of China', effective date 23 January 2012). Table 2.1 indicates persons who prepared or contributed to the Technical Report.

Table 2.1 Persons who prepared or contributed to this Technical Report

Qualified Persons responsible for the preparation of this Technical Report						
Qualified Person	Position	Employer	Independent of Silvercorp?	Date of last site visit	Professional designation	Sections of Report
Ms D. Nussipakynova	Principal Geologist	AMC Mining Consultants (Canada) Ltd.	Yes	January 2018	P.Geo.	12, 14, Part of 1, 25, and 26
Mr H. Smith	Senior Principal Mining Engineer	AMC Mining Consultants (Canada) Ltd.	Yes	January 2018	B.Sc., M.Sc., P.Eng.	2 to 6, 15, 16, 18 to 22, 24, 27, Part of 1, 25, and 26
Mr A. Riles	Associate Principal Metallurgical Consultant	AMC Mining Consultants (Canada) Ltd.	Yes	May 2011	B.Met. (Hons) Grad Dipl Business Management, M. Econ. Geol, MAIG (QP)	13, 17, Part of 1, 25, and 26
Mr P. Stephenson	Associate Principal Geologist	AMC Mining Consultants (Canada) Ltd.	Yes	No visit	P.Geo., B.Sc., FAusIMM (CP), MAIG, MCIM	7 to 11, 23, Part of 1, 25, and 26
Other Experts who assisted the Qualified Persons in the preparation of this report						
Expert	Position	Employer	Independent of Silvercorp	Visited site	Sections of Report	
Dr A. Ross	Geology Manager / Principal Geologist	AMC Mining Consultants (Canada) Ltd.	Yes	No visit	12, 14	
Mr S. Robinson	Senior Geologist	AMC Mining Consultants (Canada) Ltd.	Yes	No visit	7 to 11, 23	
Mr Leon Ma	Senior Resources Geologist	Silvercorp Metals Inc. Inc.	No	January 2018	1 to 11	
Mr Derek Liu	Chief Financial Officer	Silvercorp Metals Inc. Inc.	No	2015	15, 21	
Mr Luke Liu	Vice President China Operations	Silvercorp Metals Inc. Inc.	No	Since July 2014	15, 16, 18	
Mr L. Waldman	Senior Vice President	Silvercorp Metals Inc. Inc.	No	2014	4	
Mr J. M. Shannon	General Manager / Principal Geologist	AMC Mining Consultants (Canada) Ltd.	Yes	No visit	1, 25, 26	
Mr R. Chesher	Principal Metallurgical Consultant	AMC Consultants Pty. Ltd.	Yes	No visit	13, 17	

AMC acknowledges the numerous contributions from Silvercorp in the preparation of this report and is particularly appreciative of prompt and willing assistance of Mr Leon Ma and Mr L. Liu.

Ms Dinara Nussipakynova and Mr Herbert Smith visited the GC property in January 2018. All aspects of the project were examined by the Qualified Persons, including drill core, laboratories, underground workings, processing plant, tailings stockpile, water treatment plant, and other surface infrastructure. Other AMC employees have previously visited the site.

In preparing this report, AMC has relied on various geological maps, reports and other technical information provided by Silvercorp. AMC has reviewed and analysed the data provided and drawn its own conclusions augmented by its direct field observations. The key information used in this report is listed in Section 27, References, at the end of this report.

Much of the geological information in this report was originally written in Chinese. Translations of key technical documents and data into English were provided by Silvercorp. The Qualified Persons have no reason to believe that the translations are not credible and believe they are generally reliable but cannot attest to their absolute accuracy.

Silvercorp's internal technical information reviewed by AMC was adequately documented, comprehensive and of good technical quality. It was gathered, prepared and compiled by competent technical persons. Silvercorp's external technical information was prepared by reputable companies and AMC has no reason to doubt its validity. AMC used its professional judgement and made recommendations in this report where it deems further work is warranted.

This report includes the tabulation of numerical data which involves a degree of rounding for the purpose of resource estimation. AMC does not consider any rounding of the numerical data to be material to the project.

All currency amounts and commodity prices are stated in US dollars. Quantities are stated in metric (SI) units. Commodity weights of measure are in grams (g) or percent (%) unless otherwise stated.

This report has been produced in accordance with the Standards of Disclosure for Mineral Projects as contained in NI 43-101 and accompanying policies and documents. NI 43-101 utilizes the definitions and categories of Mineral Resources and Mineral Reserves as set out in the Canadian Institute of Mining, Metallurgy and Petroleum (CIM) Standards on Mineral Resources and Mineral Reserves Definitions and Guidelines (2014) (CIM Standards).

A draft of the report was provided to Silvercorp for checking for factual accuracy. The report is effective at 30 June 2018.

3 Reliance on other experts

The Qualified Persons have relied, in respect of legal aspects, upon the work of the Expert listed below. To the extent permitted under NI 43-101, the Qualified Persons disclaim responsibility for the relevant section of the Report.

- Expert: Henry Shi, Jun He Law Offices, Beijing, as advised in a letter of 21 March 2018 to Mr Lorne Waldman, Senior Vice President, Silvercorp Metals Inc.
- Report, opinion or statement relied upon: information on mineral tenure and status, royalty obligations, Mineral Resources tax, etc.
- Extent of reliance: full reliance following a review by the Qualified Persons.
- Portion of Technical Report to which disclaimer applies: Section 4.

The Qualified Persons have relied, in respect of environmental aspects, upon the work of the issuer's expert listed below. To the extent permitted under NI 43-101, the Qualified Persons disclaim responsibility for the relevant section of the Report.

- Expert: Mr Lai Jinming, Environmental Specialist, Silvercorp Metals Inc.
- Report, opinion or statement relied upon: information on environmental studies, permitting, social and community impact, site monitoring, remediation and reclamation, and closure plan.
- Extent of reliance: full reliance following a review by the Qualified Persons.
- Portion of Technical Report to which disclaimer applies: Section 20.

4 Property description and location

The GC property is located in the vicinity of Gaocheng village, Gaocun Township, Yun'an District, Yunfu City, Guangdong Province, People's Republic of China (Figure 4.1).

Figure 4.1 GC property location map



4.1 Exploration and mining permits

In 2008, Silvercorp acquired 100% of the shares of Yangtze Gold Ltd. (Yangtze Gold), a private British Virgin Island (BVI) company, which in turn wholly owns Yangtze Mining Ltd. (Yangtze Mining). Yangtze Mining owns a 95% interest in a Sino-Foreign joint venture company, Anhui Yangtze Mining Co. Ltd. (Anhui Yangtze). Anhui Yangtze's main asset was the GC exploration permit for the GC Mine, which was subsequently converted to a mining permit in November 2010.

Guangdong Found Mining Co. Ltd. (China), (Guangdong Found), is the designated joint venture operating company of the GC Mine. Yangtze Mining (H.K.) Ltd., a wholly owned subsidiary of Yangtze Mining, owns 95% of Guangdong Found. Guangdong Found has a 100% beneficial interest in the GC Mine. The boundaries of the mining permit were surveyed, and the boundary markers were staked in the ground by the Bureau of Land and Resources of Guangdong Province before issuing the mining permit to Guangdong Found in 2010.

On 14 June 2010 Silvercorp announced that it had been issued an Environmental Permit for the project from the Department of Environmental Protection of Guangdong Province, an essential document required for a mining permit application.

A Mining Permit was issued to Anhui Yangtze by the Ministry of Land and Resources of China on 24 November 2010. The permit is valid for 30 years to 24 November 2040, covers the entire 5.5238 km² area of the GC Mine and permits mining from 315 m to minus 530 m elevations. The permit was issued on the terms applied for and allows for the operation of an underground mine to produce silver, lead, and zinc. In June 2012, Anhui Yangtze transferred the mining permit to Guangdong Found, and a new mining permit was issued to Guangdong Found by the Ministry of Land and Resources of China on 6 June 2012.

Mining Permit Corner Points of the GC Project area are as shown below in Table 4.1.

Table 4.1 Mining Permit Corner Points of the GC Property

Point	Gauss coordinates	
	X	Y
1	2536958.82	37591830.45
2	2536977.34	37594822.59
3	2535131.42	37594834.19
4	2535112.90	37591841.69

The grid system used for the GC project is the Xi'an Geodetic Coordinate System 1980. Altitude is referred to the Yellow Sea 1956 Elevation System. The project survey control points were generated from three nearby national survey control points.

Key information contained in the Mining Permit is provided in Table 4.2.

Table 4.2 GC Mining Permit, owned by Guangdong Found

Permit No.	No. C1000002010113210083333
Owner	Guangdong Found Mining Co. Ltd.
Owner's address	48 Zhenqian Rd., Gaocun Township, Yun'an County, Yunfu City of Guangdong Province, P. R. China
Name of the mine	GC Lead and Zinc Mine of Guangdong Found Mining Co. Ltd.
Business category	Sino-Foreign cooperative enterprises
Types of ore mined	Zinc, lead, and silver ore
Mining method:	Underground mining
Production capacity:	330,000 tonne/year
Mine area	5.5238 km ²
Valid period	6 June 2012 to 24 November 2040
Issued date*	6 June 2012

*Exploration Permit issued 6 June 2012, converted to Mining Permit 24 November 2010.

Currently, GC Mine is subject to Mineral Resources taxes, levied at 3% of sales. This tax together with other government fees totals around 5% of net revenue. AMC is not aware of any additional royalties, back-in rights, payments, agreements, environmental liabilities, or encumbrances particular to the property other than those stated above.

5 Accessibility, climate, local resources, infrastructure, and physiography

The GC project is located in the vicinity of Gaocheng Village of Gaocun Township, Yun'an District, Yunfu City, Guangdong Province, China. Altitudes in the region range from 78 m to 378 m above sea level (ASL), usually 150 to 250 m ASL, with relative differences of 50 to 150 m. Vegetation is in the form of secondary forests of pine and hardwoods, bushes and grasses. Top soil covers most of the ground. Outcrops of bedrocks can only be observed in valleys.

The GC project is located west of the metropolitan city of Guangzhou, the capital of Guangdong Province. Guangzhou is located about 120 km northwest of Hong Kong and has a population of almost 14 million registered residents and temporary migrant inhabitants, as of December 2016, according to an economic report released by the Guangzhou Academy of Social Science. It is serviced by rail and daily flights from many of China's larger population centres. Access to the GC project from Guangzhou is via 178 km of four-lane express highway to Yunfu, then 48 km of paved road to the project site. A railway connection from Guangzhou to Yunfu is also available.

The region belongs to a sub-tropical monsoon climate zone with average annual temperature of 20 – 22°C. Rainfall is mainly concentrated in spring and summer from March to August. Winters feature short periods of frosting. The GC project is able to operate year-round.

Streams are well developed in the district, with the Hashui Creek flowing in the GC project area. There is a reservoir upstream of the GC project area. Small hydro power stations are developed in the region that are connected to the provincial electrical grid. There is a 10 kV power line that crosses through the project area.

A power supply system consisting of a 5.8 km power line, a 110 kV substation, and a 10 kV safety backup-circuit was completed in 2013. This system has sufficient capacity to support the current production and any envisaged future production expansion.

The economy of Yun'an District mainly relies upon agriculture and some small township industrial enterprises. Labour is locally available, and technical personnel are available in Yunfu and nearby cities. The Gaocheng village is located within the GC project area.

6 History

Various state-sponsored Chinese Geological Brigades and companies have conducted geological and exploration work in the project area. Systematic regional geological surveys covering the area started in 1959. The following is a brief history of the exploration work in the area:

- During 1959 to 1960, No. 763 Geological Brigade of Guangdong Bureau of Geology conducted a 1:200,000 regional geological survey and mapping, and regional prospecting of Mineral Resources in the area. A geological map and geological reports were published.
- From 1964 to 1967, the Comprehensive Study Brigade of Guangdong Bureau of Geology conducted general prospecting and 1:50,000 geological mapping in the area, including the current project area, and submitted a geological report.
- In 1983, the Geophysical Survey Brigade of Guangdong Bureau of Geology and Mineral Resources conducted a 1:200,000 airborne magnetic survey covering the project area.
- In 1988, the Regional Geological Survey Brigade of Guangdong Bureau of Geology and Mineral Resources conducted a 1:200,000 stream sediment survey, which covers the project area.
- In 1991, the Geophysical Survey Brigade of Guangdong Bureau of Geology and Mineral Resources conducted a 1:200,000 gravity survey covering the project area.
- In 1995, the Ministry of Geology and Mineral Resources completed the compilation and interpretation of 1:1,000,000 geochemical, geophysical and remote sensing surveys covering the area.
- During 1995 and 1996, the Geophysical Survey Brigade of Guangdong Bureau of Geology and Mineral Resources conducted a 1:50,000 soil survey, and defined some large and intensive Pb, Zn, Ag, Sn, W, and Bi geochemical anomalies, which cover the project area.
- During 1990 and 2000, the Guangdong Provincial Institute of Geological Survey (GIGS) conducted a 1:50,000 stream sediment survey, which covers the project area, and defined several intensive anomalies of Pb-Zn-Ag-Sn-Mn, leading to the discovery of the GC deposit.
- During 2001 and 2002, and again in 2004 and 2005, GIGS conducted general prospecting at the GC project area, and defined some mineralized bodies and estimated Mineral Resources for the GC deposit.
- During 2006 and 2007, contracted by Yangtze Mining, GIGS conducted detailed prospecting at the GC project area, and completed a 36-hole, 11,470 m surface diamond drilling program and 1,964 m³ of trenching and surface stripping, to update and upgrade the Mineral Resources of the GC deposit.
- In 2008, Silvercorp completed a 22-hole, 10,083 m drilling program, which resulted in the discovery of an additional 15 mineralized veins.

A summary of the historical work between 2001 and 2008 is shown in Table 6.1. Table 6.2 contains a drill record for the same period.

Table 6.1 Historical exploration work 2001 – 2008

Program	Unit	Work completed				
		2001 - 2002	2004 - 2005	2006 - 2007	2008	Total
1:10,000 Soil survey	km ²	4.0				4.0
1:10,000 soil profiling	km	12.4				12.4
1: 5,000 Hydrogeological survey	km ²			12.5		12.5
1:10,000 Geological survey	km ²	15.0				15.0
1:5000 Geological survey	km ²		5.3			5.3
1:2000 Geological survey	km ²			4.5		4.5
1:2000 topographic survey	km ²			4.5		4.5
Exploration line survey	km	3.8	2.0	6.7		12.5
Diamond drilling	m	1,010.3	983.6	11,469.8	10,083.0	23,546.7
Trenching (pitting)	m ³	3,888.0	3,582.5	1,964.1		9,434.6
Tunnelling	m	66.0				66.0
Tunnel clean-up	m	197.2		302.6		499.8
Tunnel geological mapping and sampling	m	637.2		632.6		1,269.8
Control point survey	Point			42.0		42.0
Survey of engineering points	Point		23.0	222.0		245.0
Hydrogeological observation hole	Point			2.0		2.0
Soil samples	Sample	1,116.0				1,116.0
Chemical analysis samples	Sample	454.0	182.0	2,849.0		3,485.0
Internal checking samples	Sample	17.0		275.0		292.0
External checking samples	Sample			150.0		150.0
Rock survey samples	Sample	41.0				41.0
Thin and polishing sections	Piece	34.0	8.0	27.0		69.0
Composite samples	Sample	2.0		26.0		28.0
Spectrum analysis sample	Sample			1.0		1.0
Small specific gravity samples	Sample			62.0		62.0
Artificial heavy mineral sample	Sample			1.0		1.0
Multiple element samples	Sample			3.0		3.0
Water quality samples	Sample			11.0		11.0
Rock and ore samples	Sample			38.0		38.0
Sample for metallurgical test	Sample			1.0		1.0
Metallurgical testing	Test			1.0		1.0

Table 6.2 Record of drilling 2001 – 2008

Year drilled	PQ (m) 85 mm	HQ (m) 63.5 mm	NQ (m) 47.6 mm	Total (m)
2001 – 2005		1,993.9		1,993.9
2006 – 2007	420.3	5,179.7	5,869.9	11,469.8
2008			10,083.0	10,083.0
Total (m)	420.3	7,173.6	15,952.9	23,546.7

6.1 History of mining

Prior to Yangtze Mining acquiring the GC Property, illegal mining activity resulted in the excavation of several tunnels and small scale mining of veins V2, V2-2, V3, V4, V5, V6, and V10. GIGS reported

that a total of 1,398 m of excavation comprised of 10 adits and tunnels had been completed on the property through the illegal activity.

In 2002, GIGS developed 66 m of tunnel to crosscut veins V5 and V5-1. GIGS sampled and mapped adits ML1 to ML5, ML6, ML7, ML9, and PD12.

Yangtze Mining, after its purchase of the property in 2005, mapped and sampled the accessible tunnels ML5 and ML8. Tunnel ML5 had exposure to vein V10 and tunnel ML8 had exposure to vein V2-2. Assay results of tunnel samples were used in resource estimation. Table 6.3 details the underground workings and work completed. However, there are no detailed reconciliation data available for any of the mineralization extracted.

Table 6.3 Details of historical underground workings

Tunnel / adit	Length of tunnel / adit (m)	Vein intersected	No. samples collected	Mapped and sampled by
ML1	156	V4	12	GIGS
ML2	70	V3	1	GIGS
ML3	2	V4	6	GIGS
ML4	41	V4	3	GIGS
ML5	324	V10	13	Yangtze
ML6	438	V2	25	GIGS
ML7	45	Not named, parallel to V4		GIGS
ML8	246	V2-2	19	Yangtze
ML9	46	V4		GIGS
PD12	28	V6	3	GIGS
PD4401	66	V5	5	GIGS

6.2 History of Mineral Resources

GIGS prepared a resource estimate for nine mineralized veins for the GC project after the 2004 – 2005 exploration season. GIGS has its own classification system of Mineral Resources / Reserves, which is different from CIM Standards. AMC does not believe that the GIGS estimation of resources is material to this report.

Prior to this current report, three resource estimates for the GC project have been reported:

Technical Report by SRK Consulting (SRK), dated April 2008 (entitled "Technical Report on Gaocheng Ag-Zn-Pb Project and Shimentou Au-Ag-Zn-Pb Project, Guangdong Province, People's Republic of China").

AMC June 2009 Technical Report (entitled "NI 43-101 Technical Report Update on the GC Ag-Zn-Pb Project in Guangdong Province, People's Republic of China").

AMC Technical Report (entitled "NI 43-101 Technical Report on the GC Ag-Zn-Pb Project in Guangdong Province, People's Republic of China") dated January 2012.

Table 6.4 summarizes the SRK resource estimates for thirteen 'better-explored' veins, Table 6.5 summarizes AMC's 2009 resource estimates for 27 veins, and Table 6.6 summarizes AMC's 2012 resource estimates for 25 veins.

Table 6.4 SRK April 2008 Mineral Resource estimates for the GC Project

Category	Tonnage	Ag (g/t)	Pb (%)	Zn (%)	Sn (%)	Ag (kg)	Pb (t)	Zn (t)	Sn (t)
Measured	499,793	206.63	1.31	3.94	0.14	103,270	6,546	19,712	709
Indicated	1,329,903	100.45	1.51	2.36	0.13	133,590	20,040	31,362	1,772
Inferred (o)	707,237	238.50	1.01	0.10	0.08	168,682	7,121	673	561
Inferred (s)	6,574,146	112.92	1.42	3.32	0.13	742,361	93,669	218,002	8,619
Measured + Indicated	1,829,695	129.45	1.45	2.79	0.14	236,860	26,587	51,075	2,481
Inferred	7,281,383	125.12	1.38	3.00	0.13	911,043	100,790	218,675	9,179

Note: (o) – oxidized (s) – sulphide.

Table 6.5 AMC June 2009 Mineral Resource estimates for the GC Project

Resource classification	Tonnes	Grade		
		Ag (g/t)	Pb %	Zn %
Measured	374,000	233	1.83	3.19
Indicated	6,034,000	132	1.47	3.35
Total Measured + Indicated	6,408,000	138	1.49	3.34
Inferred	7,892,000	121	1.45	2.70

Table 6.6 AMC January 2012 Mineral Resource estimates for the GC Project

Resource classification	Tonnes	Grade			Contained metal		
		Ag (g/t)	Pb %	Zn %	Ag (kg)	Pb (t)	Zn (t)
Measured	592,800	230	1.41	3.33	136,600	8,400	19,800
Indicated	7,038,700	113	1.31	3.06	797,700	92,500	215,500
Total Measured + Indicated	7,631,500	122	1.32	3.08	934,300	100,900	235,300
Inferred	7,959,800	123	1.41	2.66	976,800	112,500	211,900

Current estimates of Mineral Resources and Mineral Reserves are discussed in the relevant sections of this report.

7 Geological setting and mineralization

This section is a summary of the geological setting and mineralization presented in AMC's Technical Report titled "NI 43-101 Technical Report on the GC Ag-Zn-Pb Project in Guangdong Province, People's Republic of China" dated 22 June 2009 and SRK Consulting's "Technical Report on Gaocheng Ag-Zn-Pb Project, and Shimentou Au-Ag-Zn-Pb Project, Guangdong Province, People's Republic of China", dated April 2008.

7.1 Regional geology

The GC property is located on the east margin of the Luoding basin, east of the Wuchuan – Sihui major fault within the north portion of the Yunkai uplift of the South China Orogenic Belt. Northeast striking structures and arc structures form the basic geological framework of the region. Deposits on the property occur at the intersection of a north-easterly striking fault zone and a near east-westerly striking fault zone.

Figure 7.1 Tectonic geology map of southern China

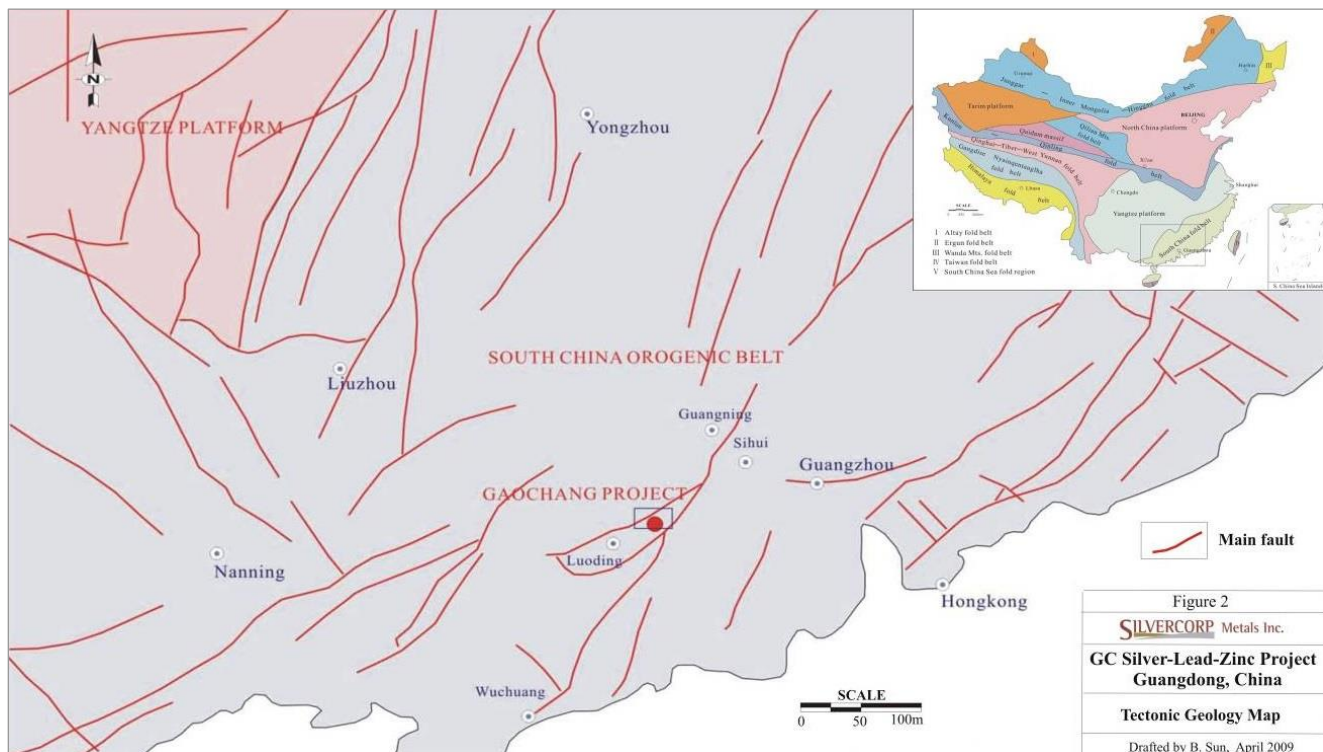

Source: Silvercorp Metals Inc.

Basement geology in the area comprises late Proterozoic Sinian sedimentary clastics and carbonate rocks; Palaeozoic (Ordovician, Silurian, Devonian, Carboniferous) sedimentary clastics and carbonate rocks; and Mesozoic (Triassic) coal-bearing clastic rocks and Cretaceous red clastic rocks. Ag-Pb-Zn poly-metallic deposits occur within late Proterozoic rocks. Cu-Pb-Zn, Mn, and Au-Ag deposits occur within Palaeozoic rocks.

Three prominent sets of structures occur within the region:

- North-easterly striking structures comprising a series of folds and faults that host some mineralized bodies.
- Approximately east-westerly striking structures which dip steeply and contain structural breccias and quartz infill within the fault zones. Prominent alteration zones occur along both sides of these structures.
- Arc or ring structures which include folds and faults surrounding the Daganshan granite body. The Pb-Zn-Ag-Sn deposits, mineralization showings, and Au-Ag-Pb-Zn geochemical anomalies occur in the arc / ring structural zone.

Palaeozoic granite batholiths and Mesozoic granite stocks and dykes occur commonly within the arc / ring structure. These intrusions are closely related with Pb-Zn-Ag poly-metallic mineralization in the region.

Figure 7.2 Regional geological map

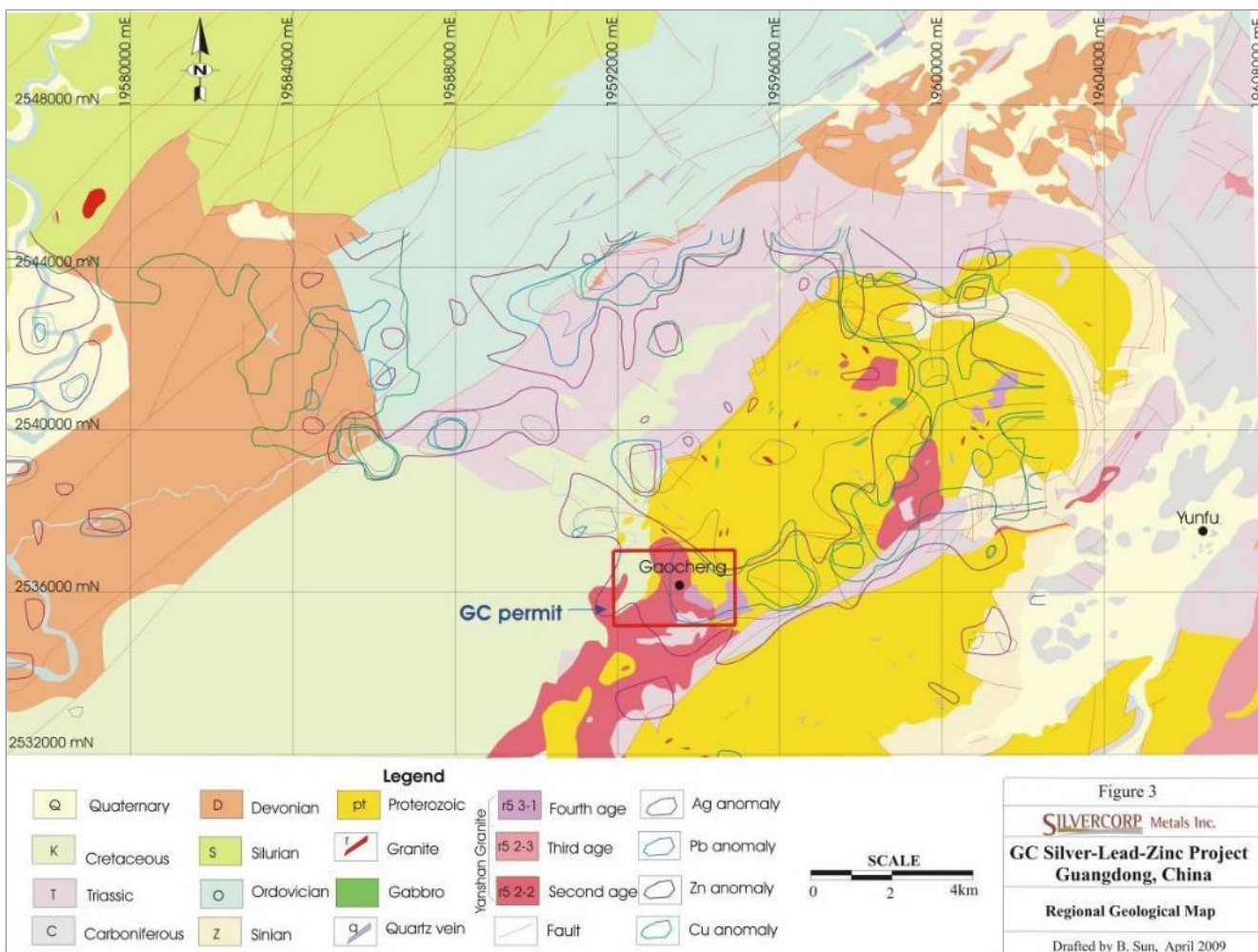

Source: Silvercorp Metals Inc.

7.2 Property geology

The GC Project is located at the intersection between the Wuchuan-Sihui Deep Fault zone and Daganshan Arc-ring structural zone.

Basement rocks within the GC Project area encompass quartz sandstone, meta-carbonaceous siltstone, carbonaceous phyllite, calcareous quartzite and argillaceous limestone of the Sinian Daganshan Formation; quartz sandstone and shale of the Triassic Xiaoyunwushan Formation, and sandy conglomerate and conglomerate of the Cretaceous Luoding Formation. These rocks are intruded by Palaeozoic gneissic, medium-grained biotite granite, and Mesozoic fine- to medium-grained adamellite, brownish, fine-grained, biotite mylonite, granite porphyry, quartz porphyry, diabase, and aplite. The Mesozoic intrusives intruded along the south and southwest contacts of the Palaeozoic granites. The majority of Ag-Zn-Pb mineralization is hosted by the Mesozoic granite. The granite dips south and strikes west northwest, parallel to the majority of mineralized veins on the GC property.

Figure 7.3 Property geology map

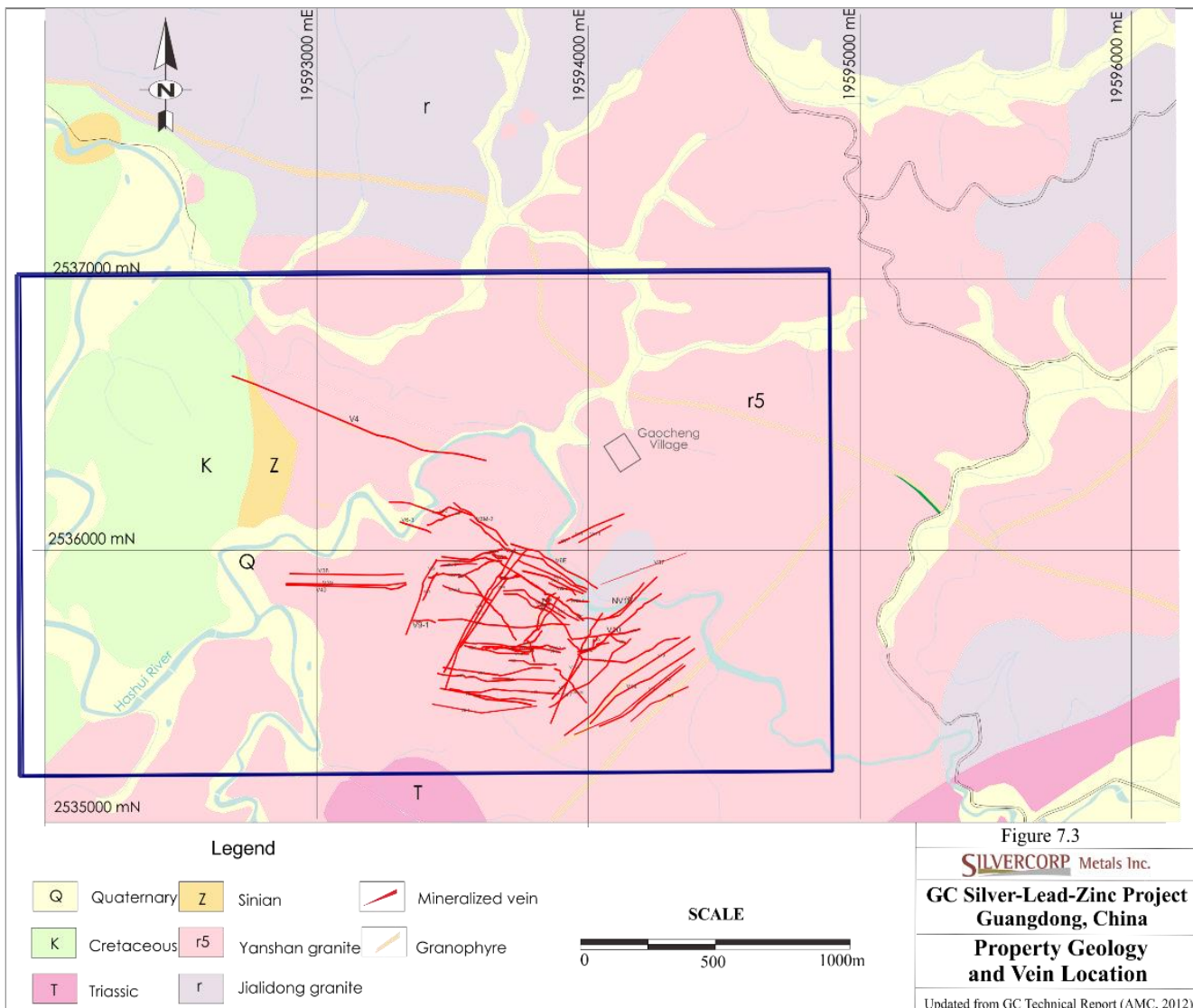

Source: Silvercorp Metals Inc.

7.2.1 Structures

The project area is situated in the southwest part of the Daganshan uplift. Structures developed in the area are mainly the NWW-EW striking Gaocheng Fault zone, the NE striking Baimei Fault zone, and the Songgui Fault zone.

Mineralization at GC is primarily hosted within a WNW-ENE trending, 4.8 km long and 2 km wide fault zone. This zone encompasses numerous veins (V2E, V2-1, V2-2, V6-0, V6-1, V6E, V6M, V6M-2, V7, and V7-3) which strike between 112° and 146° and dip between 65° to the southwest and sub-vertical. Vein V1 dips northeast with a lesser dip of around approximately 44°. The average thickness of veins is 0.89 m.

East-west striking veins include V2W, V2W-0, V2W-4, V5, V5-5, V6, V6-2, V8, V9-1, V9W-2, V9-5, V11, V16, V17, V18, and V19. These veins typically strike 65° to 110° and dip between 59° and sub-vertical to the SE and SSW (Figure 7.4 and Figure 7.5). The average thickness is around 0.9 m.

NE-striking faults cut through the NWW-striking structures with no or minor displacement. Mineralized veins including V9-9, V10, V10-1, V10-3, V10-4, NV10, V12, V13, V14, V25, V26, V28, and V29 form part of this trend. These veins are sub-parallel to the major NE striking faults F25 and F27. These veins strike between 20° and 78° and dip between 60 and 84° to the SE (Figure 7.4). The average thickness of these veins is 0.68 m.

Figure 7.4 The occurrence and distribution of mineralized veins (Level -100 m)

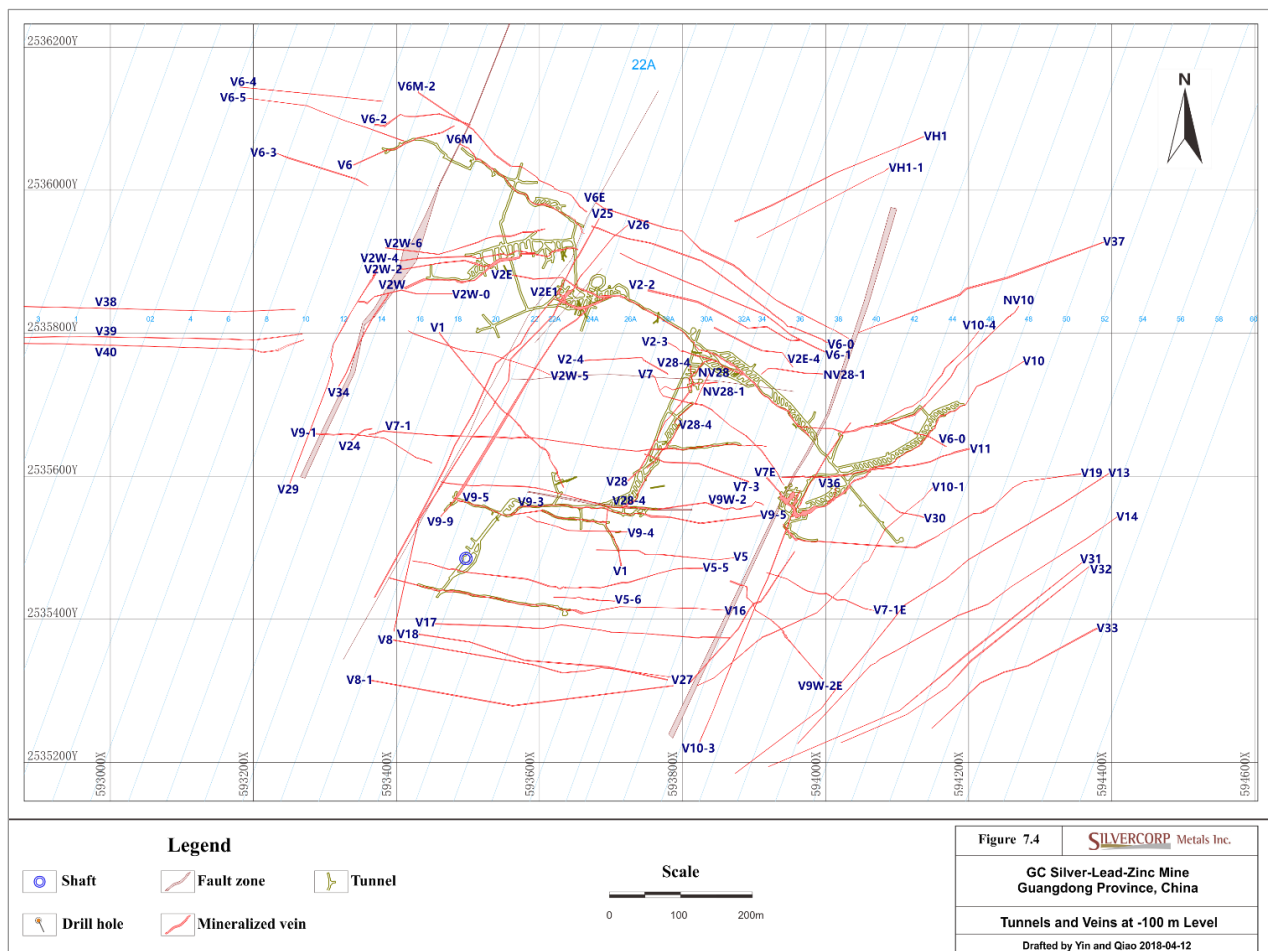

Source: Silvercorp Metals Inc.

Figure 7.5 Cross section of Exploration Line 22A

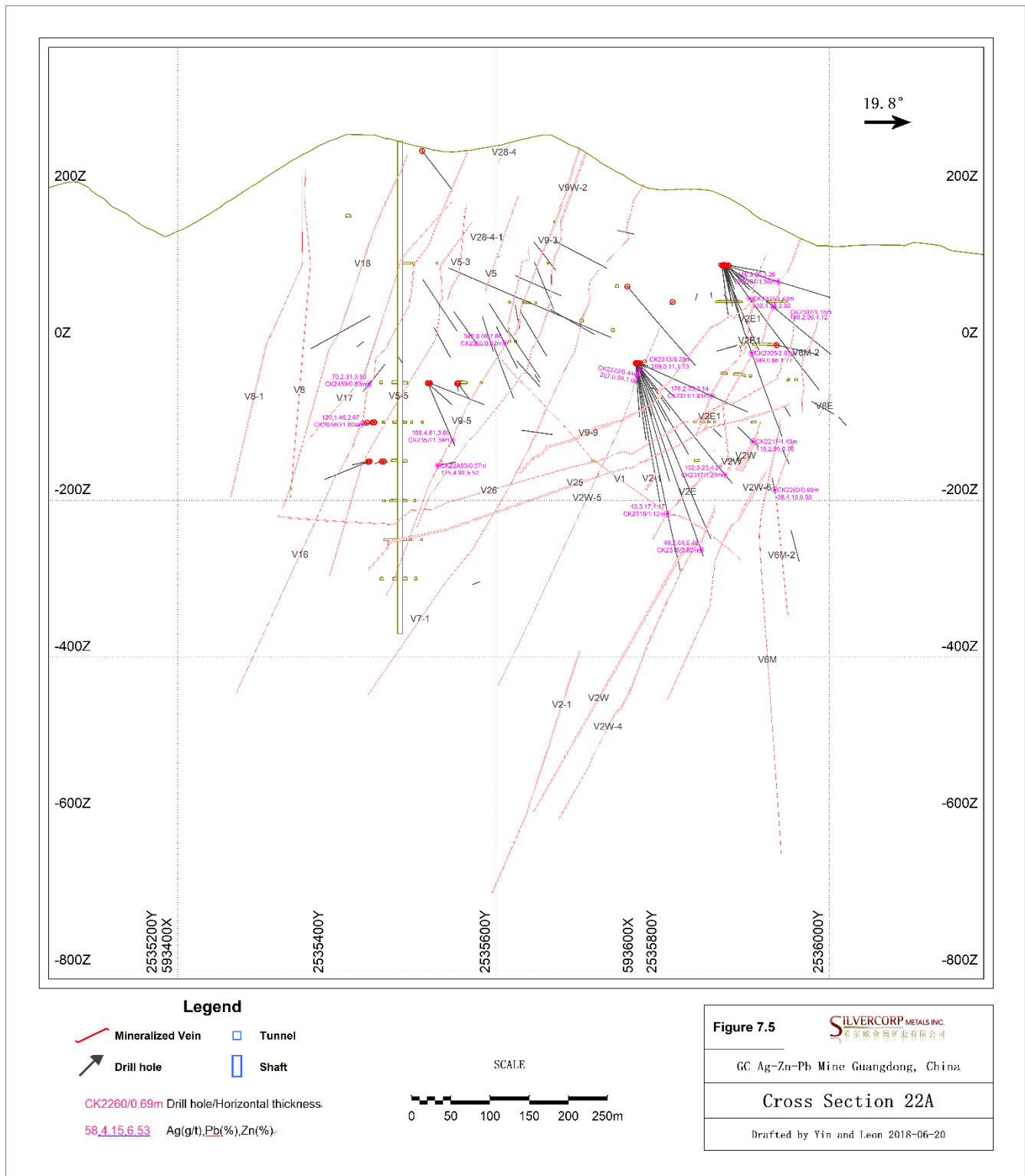

Source: Silvercorp Metals Inc.

Photos are of the NWW and NE striking faults are presented in Figure 7.6. The faults demonstrate a sharp contact between the veins and the host rock.

Figure 7.6 Fault planes



a) Vertical and smooth fault plane of NE vein V10 in an open stope of Tunnel ML5.

b) Vertical and smooth fault plane of NWW vein V2-2 in an open stope of Tunnel ML5.

Source: Silvercorp Metals Inc.

7.3 Mineralization

Ag-Zn-Pb mineralization at the GC deposit can be divided into two types: primary and oxidized. The primary mineralization is mainly composed of galena-sphalerite-silver minerals which occur sparsely, as disseminations, veinlets and lumps. Primary mineralization accounts for 95% of the entire mineral resource. Oxide mineralization occurs on and near the surface.

Mineralized veins in the GC area occur in relatively permeable fault-breccia zones. These zones are extensively oxidized from the surface to depths of about 40 m. Veins in this zone exhibit open space and boxwork lattice textures resulting from the leaching and oxidation of sulphide minerals. Secondary minerals present in varying amounts in this zone include kaolinite, hematite and limonite.

The dominant sulphide mineral is pyrite, typically comprising a few percent to 13% of the vein. Other constituents are a few percent of sphalerite, galena, pyrrhotite, arsenopyrite, magnetite, and less than a percentage of chalcopyrite and cassiterite. Metallic minerals in much smaller amounts include argentite, native silver, bornite, wolframite, scheelite, and antimonite. Metallic minerals occur in narrow massive bands, veinlets or as disseminations in the gangue. Gangue minerals include chlorite, quartz, fluorite, feldspar, mica, hornblende, with a small amount or trace amount of kaolinite, tremolite, actinolite, chalcedony, garnet, zoisite, apatite, and tourmaline.

Alteration minerals associated the GC vein systems include quartz, sericite, pyrite, and chlorite, together with clay minerals and limonite. Silicification commonly occurs near the centre of the veins. Chlorite and sericite occur near and slightly beyond the vein margins.

Quartz, pyrite, fluorite, and chlorite are closely related to the mineralization.

7.4 Characteristics of the mineralized veins

Table 7.1 presents a summary of the characteristics of selected veins on the GC property.

Table 7.1 Dimensions and occurrences of selected mineralized veins

Vein #	Length (m)	Inclined depth (m)	Elevation (m)	Strike (°)	Dip direction (°)	Average dip angle (°)	Average true thickness (m)
V2E	417	957	111-(-768)	100-124	190-214	66	1.61
V2W	270	944	180-(-702)	74-100	164-190	69	2.02
V2-1	173	696	-137-(-766)	117-120	207-210	65	1.03
V1	515	553	-28-(-402)	320-349	50-69	44	0.75
V9-5	275	658	113-(-484)	72-103	162-193	65	0.88
V7E	220	386	0-(-348)	69-138	159-228	64	1.42
V16	477	706	197-(-447)	91-95	181-185	66	0.75
V10-1	482	571	185-(-324)	47-55	137-145	66	0.58
V4	1227	595	166-(-415)	94-119	184-209	77	0.8
V2-4	263	648	-111-(-688)	99-121	189-211	63	1.33
V13	738	540	163-(-297)	46-58	136-148	60	0.44
V6M	246	259	82-(-176)	112-130	202-220	89	0.83
V2E1	117	581	42-(-480)	67-114	157-204	64	1.46
V19	470	584	174-(-332)	63-104	153-194	59	0.78
V28-4	283	690	207-(-400)	33-47	123-137	60	0.84
V2W-6	236	473	(-15.2)-(-450.9)	86-75	170.31	69	0.93
V6-0	343	703	71-(-563)	100-129	190-219	64	0.65
V9W-2	550	767	180-(-523)	72-104	162-194	66	0.85
V14	522	652	284-(-315)	54-57	144-147	68	0.51
V7-1	577	749	161-(-518)	93	183	65	0.63
V6-1	323	734	95-(-564)	94-128	184-218	64	0.84
NV10	370	570	130-(-398)	85-125	175-215	67	0.67
V6-5	245	199	96-(-393)	97-111	187-201	81	0.43
V28	139	825	212-(-517)	23-38	113-128	62	0.8
V10	392	506	126-(-344)	53-59	143-149	68	0.75
V5-5	416	420	114-(-278)	83-110	173-200	69	0.81
V40	490	743	184-(-555)	91	181	84	0.59
V6M-2	315	461	25-(-435)	124-155	214-245	87	0.89
V7	231	840	149-(-614)	117-135	207-227	66	0.65
V29	238	377	187-193	20-27	110-117	84	0.78
V6-2	134	364	-16-(-366)	54-109	144-199	74	1.8
V33	318	248	276-(-231)	43-68	133-158	68	0.81
V8-1	396	417	200-(-208)	90-100	180-190	78	0.76
V31	523	597	277-(-269)	50-65	140-155	66	1.11
V18	328	468	205-(-239)	93-101	183-191	67	0.86
V6	200	420	31-(-375)	60-68	150-158	75	0.99
V17	416	480	167-(-264)	94-109	184-199	62	0.68
V12	719	398	220-(-145)	46-55	136-145	70	0.59
NV28-1	306	433	130-(-259)	67-96	157-185	65	0.93
VH1	290	270	95-(-175)	68	158	89	0.8
V8	400	418	220-(-197)	91-100	181-190	87	0.35
V9-9	364	438	232-(-177)	30-72	120-162	69	0.75
V9-3	339	254	249-8	96	186	71	0.9

Vein #	Length (m)	Inclined depth (m)	Elevation (m)	Strike (°)	Dip direction (°)	Average dip angle (°)	Average true thickness (m)
NV28	235	251	97-(-104)	67-95	157-185	65	0.89
V11	260	496	91-(-345)	74-78	164-168	62	0.74
V25	602	652	120-(-437)	28-36	118-126	61	0.75
V26	635	670	126-(-437)	27-35	117-125	60	0.79
V6-4	200	227	82-(-137)	96	186	75	0.36
V27	305	468	84-(-347)	36-47	126-137	68	0.66
V43	199	135	131-(-3)	135	225	84	0.68
V24	86	280	121-(-141)	73-97	163-187	73	0.83
VH1-1	213	337	154-(-182)	60	150	86	0.46

Source: Silvercorp Metals Inc.

7.5 Other mineralization features

The following are additional mineralization features of the GC deposit.

- High-grade shoots of Ag-Zn-Pb mineralization are commonly associated with the intersections of the NWW and east-west striking faults. This intersection results in east plunging shoots of high grade mineralization.
- Ag-Zn-Pb mineralization is most intense, continuous, and wide within fault breccia zones.
- Grade contours of individual metals within mineralized veins suggests that the Zn mineralization is more continuous than Ag and Pb. Ag and Pb appear to be locally concentrated.

8 Deposit types

This section is a summary of the geological setting and mineralization descriptions presented in the Technical Report titled "NI 43-101 Technical Report Update on the GC Ag-Zn-Pb Project in Guangdong Province, People's Republic of China" dated 18 June 2009. The original source of data was derived from the previous Technical Report on the property titled "Technical Report on Gaocheng Ag-Zn-Pb Project, and Shimentou Au-Ag-Zn-Pb Project, Guangdong Province, People's Republic of China", dated April 2008.

The poly-metallic mineralization of the GC deposit belongs to the mesothermal vein infill style of deposit and exhibits the following characteristics:

- The mineralization occurs as veins which are structurally controlled within broader alteration zones. The alteration can reach more than a few meters along the faults distributing in both hanging wall and footwall.
- The veins have a sharp contact with the host rocks and steeply dip at angles between 60 – 85°.

In general, the Ag-Zn-Pb mineralization occurs along the strike of the faults. The veins have true widths varying from just over 0.1 m to over 10 m. They have been traced for over 1,250 m along the strike, and approximately 550 m down dip.

9 Exploration

The section describes surface and underground exploration activities carried out by Silvercorp between 2008 and 2017.

Surface-based exploration occurred primarily during 2008. This work included soil sampling, geological mapping and trenching (Table 9.1).

Table 9.1 Surface exploration programs completed in 2008

Program	Unit	Work completed
Trenching (pitting)	m ³	740
Soil samples	Samples	535
	Line km	10

Source: Silvercorp Metals Inc.

In addition to surface samples Silvercorp also completed more than 40 km of underground tunnelling and sampling at the property between 2012 and 2017.

Details of drill programs completed between 2008 and 2017 are presented in Section 10 of this report.

The grid system used for the GC project is Xi'an Geodetic Coordinate System 1980. The altitude referred to is the Yellow Sea 1956 Elevation System. The project survey control points were generated from three nearby national survey control points. The control points were surveyed using four NGS-9600 GPS receivers. Survey machines used for topographical survey and geological points, trenches, adits, and drillhole collars were Topcon GTS-Serial Total Station Instrument – XJ0747 and one NX2350 and Sokkia SET-230PK Total Station Instrument.

9.1 Soil geochemical program

In 2008, a 1:10,000 scale soil geochemical survey was completed by Silvercorp on the southern portion of the property. The soil sampling program comprised 20 m spaced samples along 200 m spaced lined covering a 2.22 km² area where no previous drilling had occurred. A total of 535 soil samples were collected from C-horizon soils. Samples were analysed by aqua regia digestion and ICP analysis for Au, Ag, Cu, Pb, Zn, Mo, and As.

Three significant Ag-Zn-Pb geochemical anomalies were identified (Figure 9.1).

- AS1 anomaly: encompasses an area 500 m in length and 50 to 100 m in width and includes peak values of 2.1 ppm Ag, 0.19% Pb, and 0.03% Zn at the eastern extent of V4 vein along F4 fault. Trenching was subsequently carried out over this anomaly.
- AS2 anomaly: encompasses an area 500 m length and 20 to 200 m in width and includes maximum values of 14.5 ppm Ag, 0.11% Pb, and 0.02% Zn.
- AS3 anomaly: is approximately 500 m in length and between 20 and 50 m wide (between Exploration Lines 28 – 44). The anomaly increases to 250 m in width to the east (between Lines 36 to 44).

Figure 9.1 Soil geochemical anomalies of Ag, Pb, and Zn on the GC Property

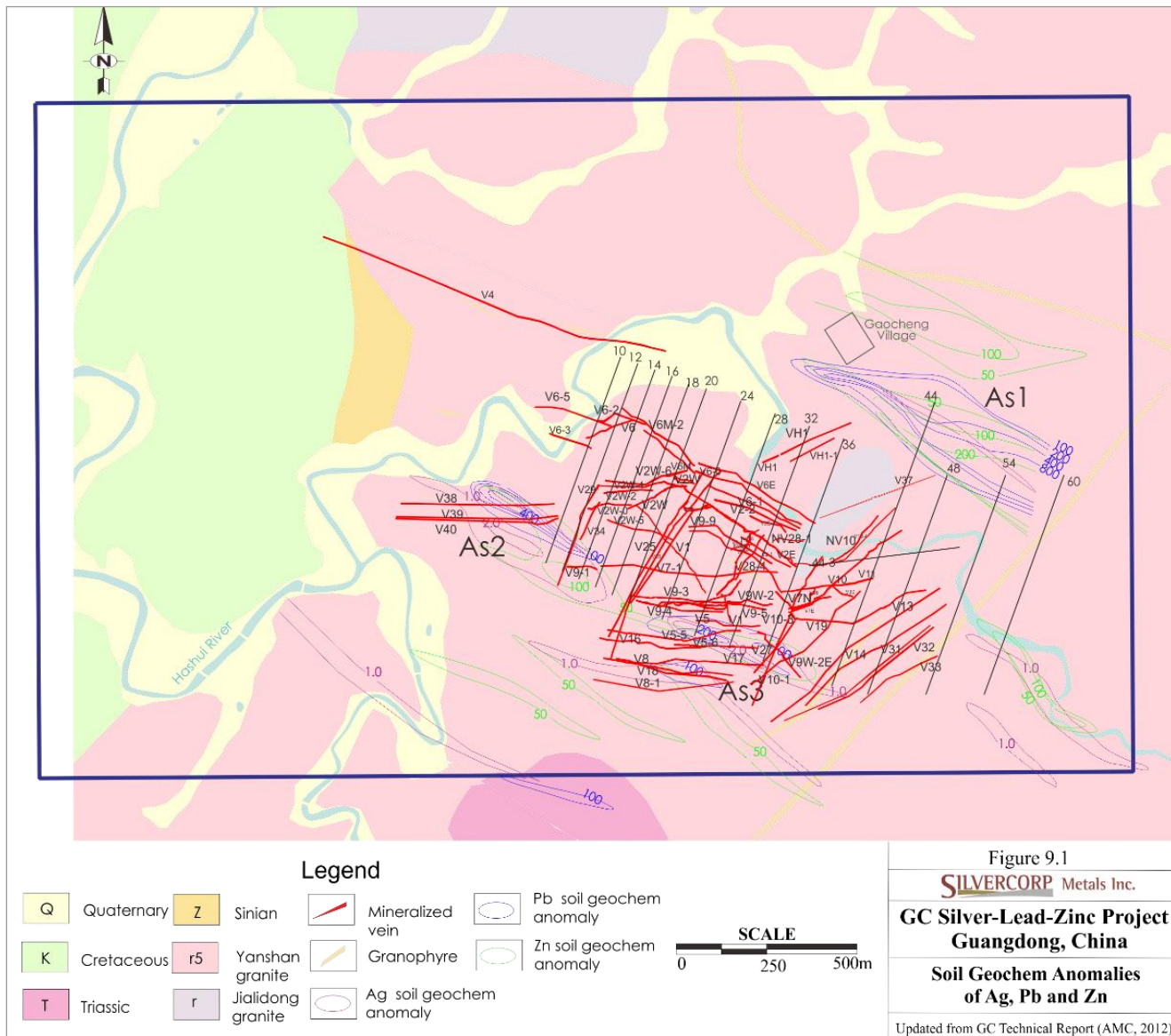

Source: Silvercorp Metals Inc.

9.2 Topographic and geological mapping

The GIGS conducted 1:10,000, 1:5,000, and 1:2,000 geological mapping programs, and a 1: 2,000 topographic survey covering the GC project area in 2008. The geological mapping programs established stratigraphic sequences, and size and distributions of intrusions and faults, which was used as a framework for exploration targeting.

9.3 Trenching and pitting

Based on the soil geochemical and surface mapping, Silvercorp conducted trenching and pitting programs on the GC property. The program exposed the mineralized veins on the surface and at shallow depth. A total of seven pits and one trench were dug by Silvercorp exposing three veins.

Table 9.2 presents results of this program.

Table 9.2 Trenches and pits completed by Silvercorp in 2008 with vein highlights

Trench / pit	Section#	Azimuth	Volume (m ³)	Vein exposed
BT08-1	40	240°	224	0.80 m wide V5-1, containing 25 g/t Ag
BT08-2	44	235°	24	0.95 m wide V7-0, containing 21 g/t Ag
BT08-3	52	210°	32.4	No vein intersected
BT08-4	52	310°	24	No vein intersected
BT08-5	52	340°	52.8	0.80 m wide V7-0, containing 61 g/t Ag
BT08-6	44	230°	33.6	0.65 m wide V5-1, containing 98 g/t Ag
BT08-7	30	340°	118.8	0.75 m wide V5-1, containing 18 g/t Ag
TC5201	52	185°	230.4	1.00 m wide V4, containing 0.31% Pb and 0.13% Zn

Source: Silvercorp Metals Inc.

The trenches or pits were dug perpendicular to striking direction of a soil geochemical anomaly or alteration zone. The trenching or pitting was undertaken by digging into bedrock approximately 0.3 to 0.5 m.

Figure 9.2 Trenches and pits on the GC Property

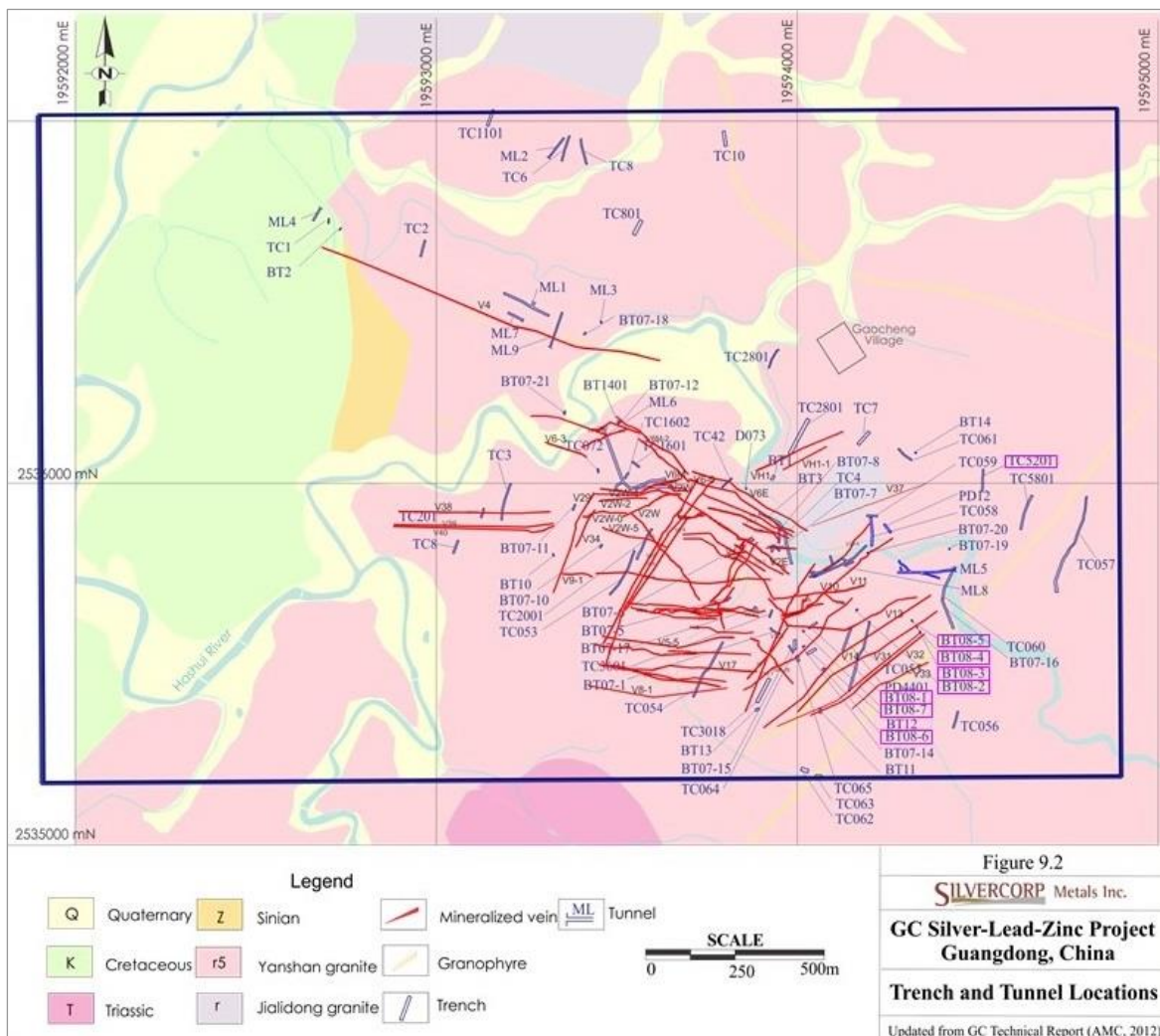

Source: Silvercorp Metals Inc.

Note: Silvercorp acquired the GC property in 2008. Silvercorp 2008 trenches highlighted.

9.4 Underground works

Underground tunnelling programs comprising 40,862 m of tunnelling were completed on the GC property between 2012 and 2017. These programs comprised 27,403 m of drifting along mineralized structures, 7,292 m of crosscutting across mineralized structures, and 6,167 m of raises (Table 9.3). Drifts and crosscuts were developed at 40 m intervals vertically to increase geological confidence in the Mineral Resource.

Channel samples across the mineralized vein structures were collected across the back of the adits at 5 m intervals, with the spacing of channel sample lines increasing to 15 or 25 m in the non-mineralized sections of the vein structures. Individual channels consist of multiple chip samples, cut across the mineralization and associated wall rocks across the tunnel. Details of the procedures and parameters relating to the underground channel sampling and discussion of the sample quality are given in Section 11.

A total of 44,166 channel / chip samples were collected from the mine areas during the period. Table 9.4 summarizes the characteristics of the mineralized veins exposed by the underground works and includes Ag, Pb, and Zn assay highlights. Figure 9.3 outlines channel sample density and location of drifts on one of the main veins at GC Mine.

Table 9.3 Summaries of underground works between 2012 and 2017

Underground works	2012	2013	2014	2015	2016	2017	Total
Drift metres	2,379	5,321	3355	6,734.2	4,328.2	5,285.5	27,403.1
Crosscut metres			1060	2,286.2	1,431.7	2,513.7	7,291.6
Raise metres				1,037.6	2,461.5	2,667.9	6,167.0
Total metres	2,379	5,321	4415	10,058.0	8,221.4	10,467.0	40,861.6

Source: Silvercorp Metals Inc.

Figure 9.3 Longitudinal projection of vein V2E

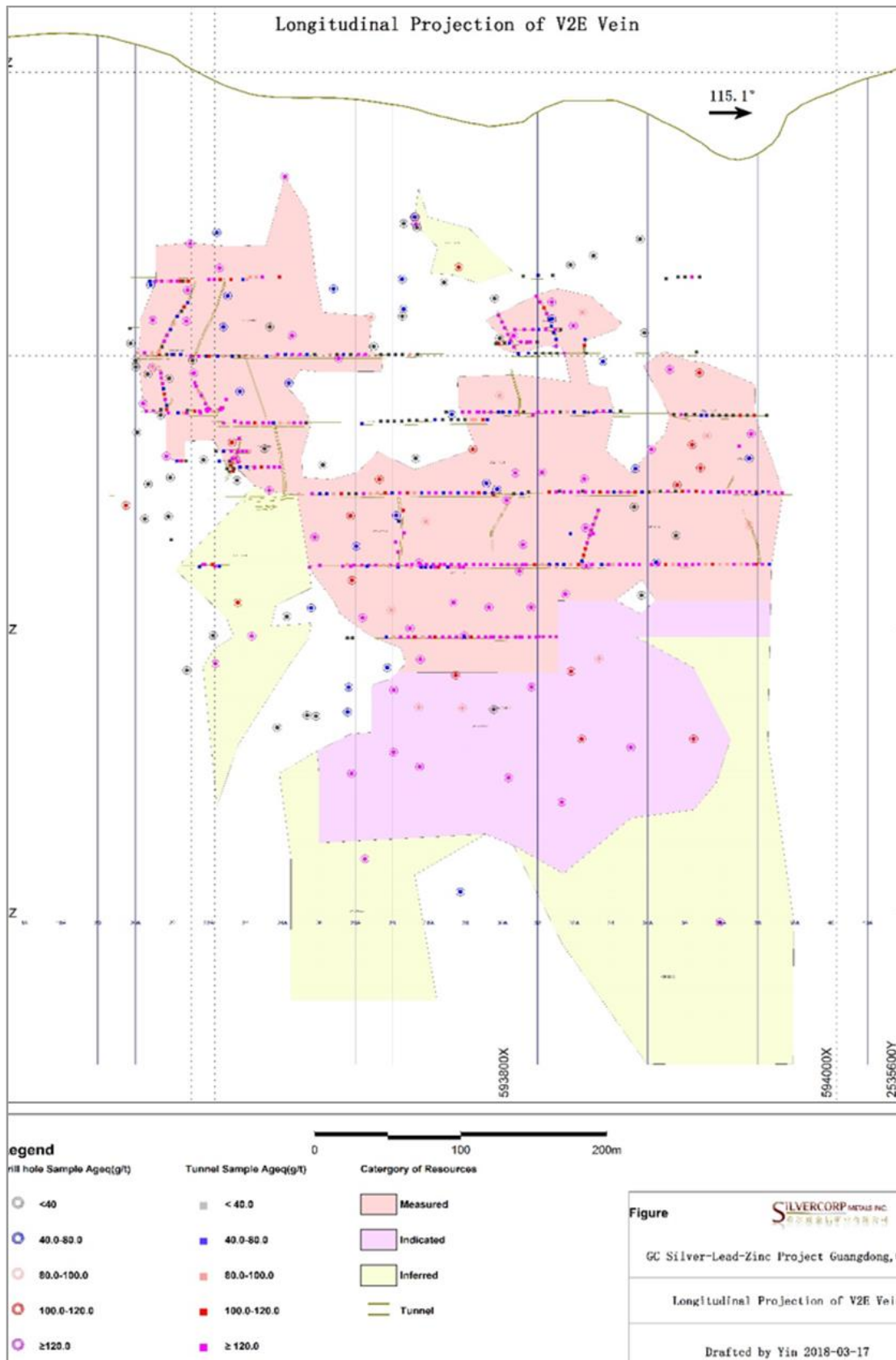

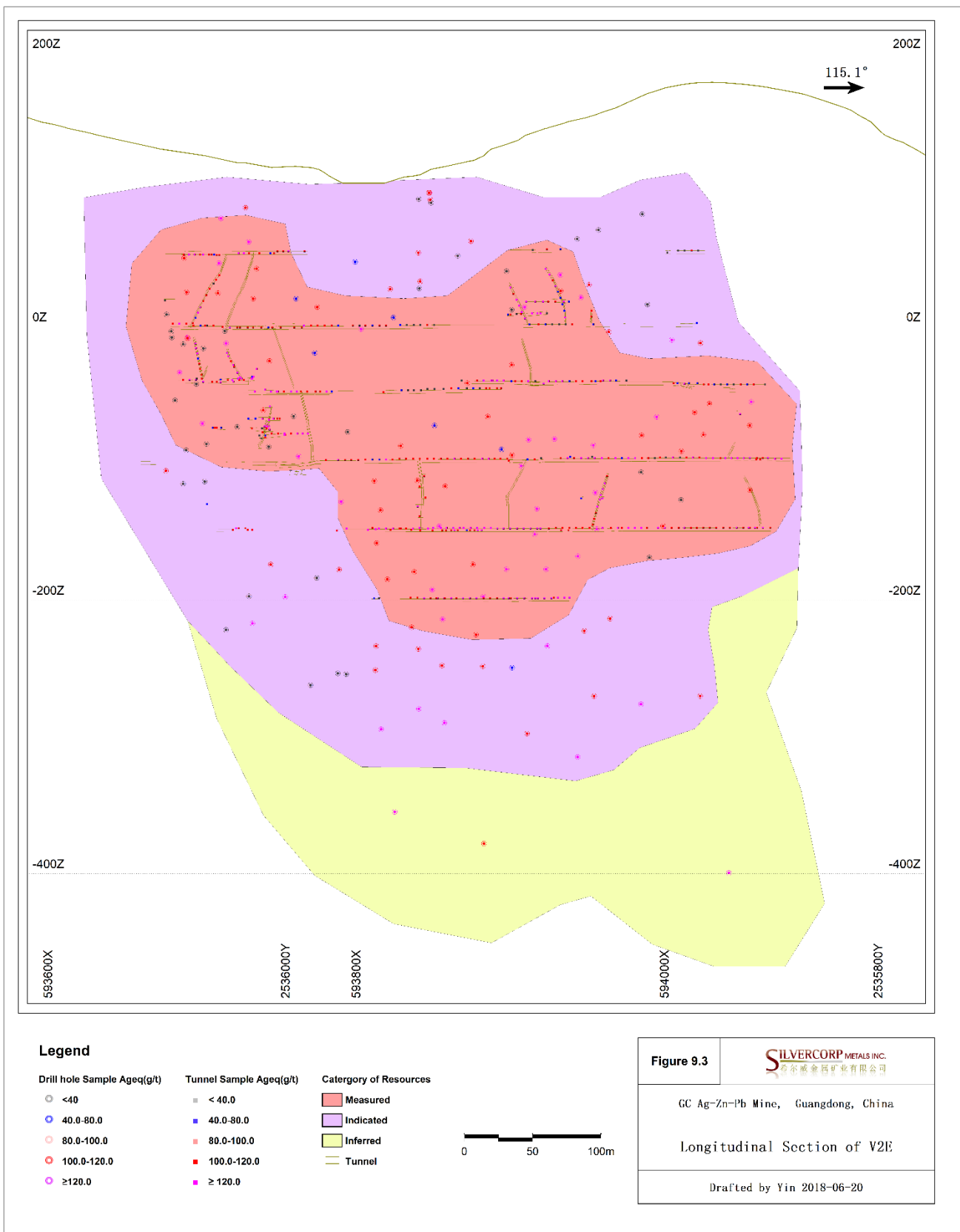

Source: Silvercorp Metals Inc.

Ag equivalent is calculated according to the following formula: $AgEq = 44.6 * Pb\% + 43.5 * Zn\% + Ag \text{ g/t}$.

Table 9.4 Underground tunnelling program – mineralization highlights

Adit ID	Vein	Elevation (m)	Length of mineralized vein (m)	Width of mineralized veins (m)	Weighted average grade			Year
					Ag (g/t)	Pb (%)	Zn (%)	
-150-V1-24AYM	V1	-150	96	1.31	77	3.58	3.24	2016
V1-(-150)-32AYM	V1	-150	62	1.53	56	3.85	3.81	2017
-50-V2-20WYM	V2W	-50	160	3.15	178	2.19	3.20	2013
V2W-(-40)-14YM	V2W	-40	38	1.45	116	0.28	6.28	2017
-50-V2-16WYM	V2W	-50	35	1.70	91	0.41	4.70	2014
V2W-(-150)-22YM	V2W	-150	128	1.89	132	2.77	3.48	2017
V2W-(-150)-22AYM	V2W	-150	54	8.00	132	3.12	4.63	2017
-50-V2E-22YM	V2E	-50	112	2.55	82	1.02	2.45	2015
V2E-(-75)-22AEYM	V2E	-75	32	1.67	148	1.68	3.46	2017
V2E-(-150)-26EYM	V2E	-150	300	1.70	134	2.85	3.89	2017
V2E-(-200)-28EYM	V2E	-200	117	2.69	99	1.25	4.19	2017
-50-V2E-1-22AYM	V2E1	-50	40	3.98	112	1.15	1.95	2016
V2E1-(-200)-26AYM	V2E1	-200	71	2.70	163	2.18	2.79	2017
V6-(-50)-12AYM	V6	-50	40	1.42	115	1.29	6.89	2017
V6-(-100)-12WYM	V6	-100	46	1.11	84	1.52	3.52	2017
+50-V6-21WYM	V6M	50	97	1.15	56	1.93	2.02	2015
0-V6-18WYM	V6M	0	50	1.50	40	2.84	2.52	2014
-100-V6-18EYM	V6M	-100	60	1.80	31	2.77	2.05	2015
V6M-(-150)-18AYM	V6M	-150	21	1.56	158	14.81	8.71	2017
-50-V2E-40WYM	V7E	-50	55	1.10	184	5.67	3.79	2016
V7E-(-100)-40YM	V7E	-100	110	1.75	106	2.14	4.04	2016
+100-V9W-2-YM	V9W-2	100	64	1.48	217	0.98	2.50	2012
V9W-2-50-28YM	V9W-2	50	93	1.29	122	1.17	3.43	2013
0M-V9W-2-28EYM	V9W-2	0	75	1.02	122	1.21	2.63	2015
+50-V9-3-25YM	V9-5	50	50	1.90	216	0.68	6.04	2013
-50-V9-3-23WYM	V9-5	-50	90	1.14	89	0.39	6.12	2014
-50-V9-3-23EYM	V9-5	-50	46	1.19	123	2.87	4.28	2014
V9-5-(-100)-28WYM	V9-5	-100	73	1.08	85	3.00	2.38	2017
V9-5-(-150)YM	V9-5	-150	80	1.78	95	1.91	4.41	2017
V9-5-(-150)-30WYM	V9-5	-150	150	1.45	96	3.41	3.57	2017
V9-5-(-200)-24AYM	V9-5	-200	121	1.24	62	2.32	3.49	2017
0-V10-42NYM	V10	0	47	2.00	187	5.32	4.29	2015
-50-V10-42ANYM	V10	-50	88	1.70	74	2.33	4.40	2016
-100-V10-40AYM	V10	-100	210	1.29	41	1.29	3.34	2017
100-V10-1-40NYM	V10-1	100	262	1.05	127	1.21	8.71	2015
50-V10-1-40YM	V10-1	50	200	0.99	76	0.90	4.69	2016
V10-1-0-42SYM	V10-1	0	145	1.57	101	0.86	4.16	2016
V10-1-(-50)-42ASYM	V10-1	-50	40	0.94	203	1.95	7.68	2017
V12-50-44AYM	V12	50	70	1.24	52	0.22	5.23	2016
+100-V28-28EYM	NV28	100	57	1.52	210	1.88	3.46	2013
NV28-50-(28-32A)YM	NV28	50	115	1.27	146	3.73	2.90	2014
0M-V28-30EYM	NV28	0	42	1.72	108	2.11	6.02	2014
-50-V28-WYM	NV28	-50	35	1.67	141	2.73	3.75	2014

Adit ID	Vein	Elevation (m)	Length of mineralized vein (m)	Width of mineralized veins (m)	Weighted average grade			Year
					Ag (g/t)	Pb (%)	Zn (%)	
V24-0-14SWYM	V24	0	90	1.10	312	2.63	5.81	2017
V24-(-40)-14AYM	V24	-40	49	1.14	306	1.09	7.39	2017
NV10-107-44SYM	NV10	107	83	1.31	125	1.05	2.51	2015
NV10-60-42AYM	NV10	60	63	1.26	122	1.98	3.17	2017
NV10-(-100)-44AWYM	NV10	-100	111	1.63	38	0.78	4.37	2017
50-V36-38SYM	V36	50	43	0.80	236	5.66	2.48	2015

Source: Silvercorp Metals Inc.

10 Drilling

10.1 Historic drilling (pre-2008)

A total of 43 diamond drillholes for a combined total of 13,463.74 m were drilled on the GC property between 2001 and 2007 prior to the property acquisition by Silvercorp. Diamond drillholes were drilled using PQ size in overburden, then reduced to HQ size for up to 100 m depth. The remainder of a hole was drilled using NQ size unless the hole was planned to drill in excess of 600 m in length. Core recoveries varied from 85 to 100%, averaging 99%.

Drilling statistics are presented in Table 10.1.

Table 10.1 Meters of various drill core sizes prior to acquisition by Silvercorp

Year drilled	PQ -85 mm (m)	HQ-63.5 mm (m)	NQ-47.6 mm (m)	Total (m)
2001-2005		1993.91		1993.91
2006-2007	420.27	5179.68	5869.88	11469.83
Total (m)	420.27	7,173.59	5869.88	13,463.74

Source: Silvercorp Metals Inc.

10.2 Silvercorp drilling (2008 – 2017)

Silvercorp completed its first phase of diamond drilling on the GC property in 2008. Detailed systematic drilling commenced on the property in 2011 and continued through to 2017. All Silvercorp drilling was completed as NQ sized core.

All drill programs were managed by Silvercorp. Drillhole collars were surveyed using a total station. Down hole surveys were completed every 50 m downhole using a Photographical Inclinator manufactured by Beijing Beizheng Weiye Science and Technology Co. Ltd (Chinese made equivalent of a Sperry-Sun downhole survey tool). Surface drillhole collars were cemented after completion and locations of drillholes were marked using 50 x 30 x 20 cm concrete blocks.

Core recoveries from Silvercorp drilling programs varied between 41.67% and 99.96% averaging 96.85%. AMC reviewed the relationship between grade and core recovery and found no bias.

All drill core was stored in a clean and well-maintained core shack in the GC camp complex (Figure 10.1). This core shack is locked when unattended and monitored by two security personnel 24 hours a day.

Figure 10.1 Drill core storage facility



a) Drill core racks in core shack



b) Drill core racks in core shack

Source: Silvercorp Metals Inc.

10.2.1 2008 drill program

In 2008, Silvercorp completed a 22-hole (10,082.6 m) drilling program, which resulted in the discovery of 15 mineralized veins. 2008 drillhole locations are shown in Figure 10.2.

Figure 10.2 Drilling completed on the GC Property

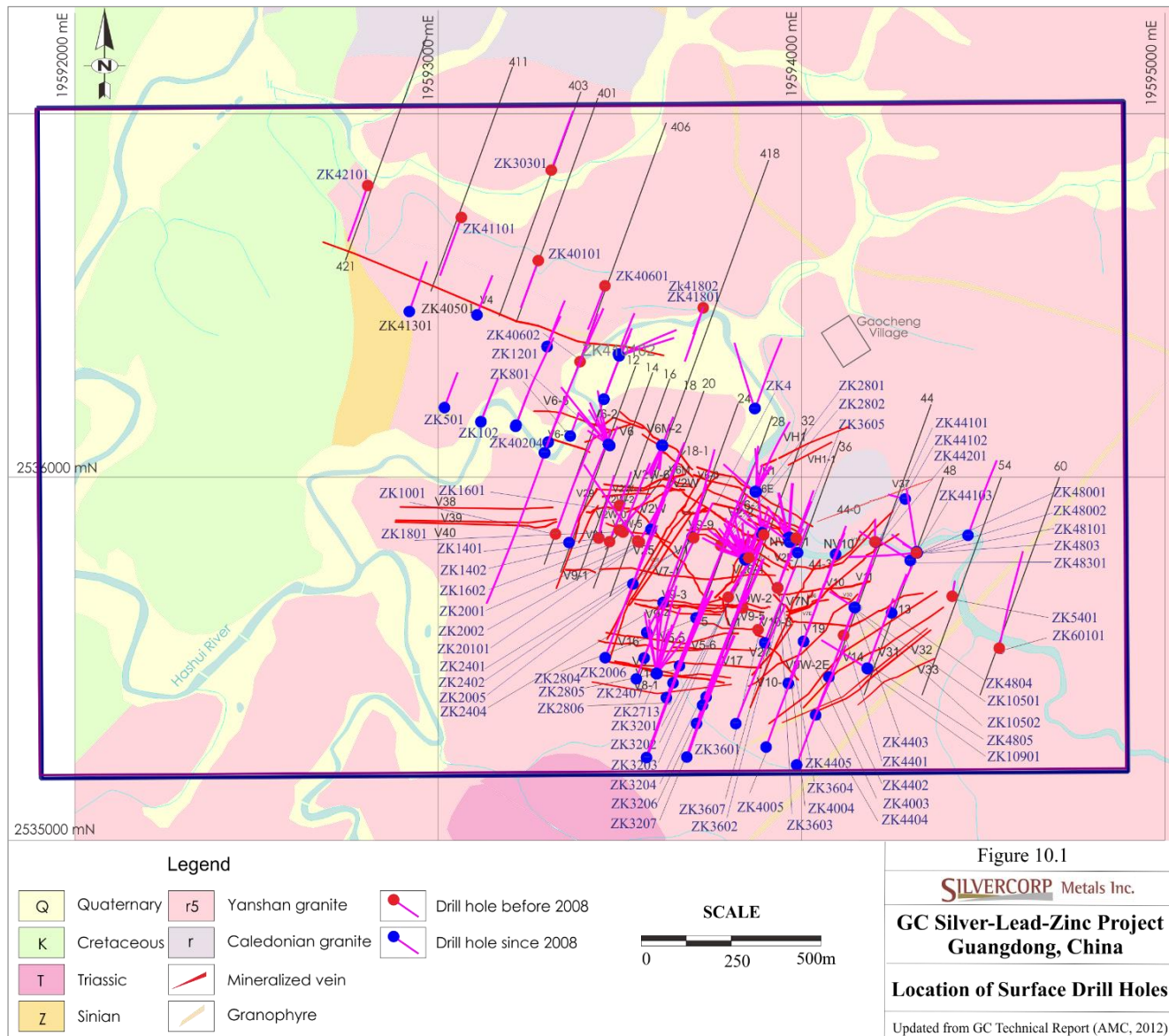

Source: Silvercorp Metals Inc.

Notes: Silvercorp acquired the GC property in 2008. Silvercorp drillhole collars are shown in blue.

10.2.2 2011 to 2017 drill programs

Silvercorp commenced a detailed, systematic drilling program at the GC project in 2011. Between 2011 and 2017, a total of 1,066 diamond drillholes (167,516 m) were completed. This total includes 962 underground diamond drillholes and 104 surface diamond drillholes. A total of 23,067 samples were taken from the drill core.

In total, 867 drillholes hit mineralization with AgEq greater than 100 g/t and a further 91 drillholes intersected mineralization with AgEq between 50 and 100 g/t (Table 10.2). Note: Ag equivalent is calculated using the equation $AgEq = 44.6 * Pb\% + 43.5 * Zn\% + Ag$ g/t. The assumptions used to derive the Ag equivalent formula is discussed in detail in Section 15 of this report.

Table 10.2 presents drilling statistics by year for holes drilled from surface and underground setups. All 2011 drilling was completed from surface. As drill target depths increased, underground drilling was increasingly utilized. Since 2014, all diamond drilling has been completed using underground setups.

Table 10.2 Drilling programs between 2011 and 2017

Year	Metres drilled	Holes completed		Samples collected	Hole with Ag equivalent between 50 and 100 g/t	Holes with > 100 g/t Ag equivalent
		Underground	Surface			
2011	14,370	0	34	1872	3	25
2012	26,393	108	25	4540	8	112
2013	45,975	245	45	7302	22	242
2014	23,536	152	0	1818	9	130
2015	23,846	158	0	1721	13	123
2016	11,825	128	0	1,930	18	101
2017	21,572	171	0	3,884	18	134
Total	167,516	962	104	23,067	91	867

Source: Silvercorp Metals Inc.

Note: Ag equivalent is calculated using the equation $AgEq = 44.6 * Pb\% + 43.5 * Zn\% + Ag \text{ g/t}$.

The majority of drillholes were drilled as inclined holes to test multiple vein structures. Underground drillholes were drilled as fans of multiple holes from single set ups (Figure 10.3).

Significant high-grade mineralized zones have been exposed at and below the current production levels, and major mineralized zones have been extended along strike and downdip.

Figure 10.3 presents a level plan of drilling at the 0 level. Table 10.3 presents drillhole intersections >100 g/t AgEq by vein. Cross sections of drilling are presented in Figure 10.4, Figure 10.5, and Figure 10.6. A longitudinal section for vein 2E is presented in Figure 10.7. Table 10.4 provides data for drillholes highlighted in Figure 10.5.

Table 10.3 Drillhole intersections >100 g/t AgEq by vein

Target vein	Number of holes drilled	Holes with > 100 g/t Ag equivalent intersection	Depth (elevation m)
V2W	141	94	96-(-328)
V2E	119	75	97-(-431)
V9W-2	108	48	162-(-307)
V16	96	47	195-(-177)
V9-5	94	42	142-(-306)
V28-4	74	38	204-(-314)
V7-1	112	35	234-(-337)
NV28	51	34	97-(-223)
V2E1	42	29	87-(-270)
V9-3	85	26	167-(-296)
V10	47	22	99-(-250)
V17	58	22	152-(-127)
V28	45	22	150-(-146)
V6M	40	21	56-(-262)
V2-3	42	20	110-(-127)
V10-1	30	19	152-(-227)
V9-9	49	18	217-(-165)
V2W-5	23	17	62-(-103)
V5-5	54	16	103-(-219)
V7	39	16	95-(-424)
V13	30	15	176-(-141)
V14	25	15	264-(-142)
NV10	31	14	107-(-285)
NV28-1	47	14	110-(-240)
V19	29	14	130-(-314)
V12	29	13	199-(-35)
V26	62	13	133-(-343)
V5-1	22	13	156-(-44)
V6	19	13	79-(-269)
V7-3	22	13	158-(-115)
V5	39	12	129-(-235)
V6M-2	29	12	24-(-235)
V7E	14	11	(-32)-(-251)
V5-3	28	10	166-(-12)
V25	42	9	118-(-377)
V29	20	9	162-(-58)

Source: Silvercorp Metals Inc.

Note: Ag equivalent is calculated using the equation $AgEq = 44.6 * Pb\% + 43.5 * Zn\% + Ag \text{ g/t}$.

Figure 10.4 Cross section on Exploration Line 22A

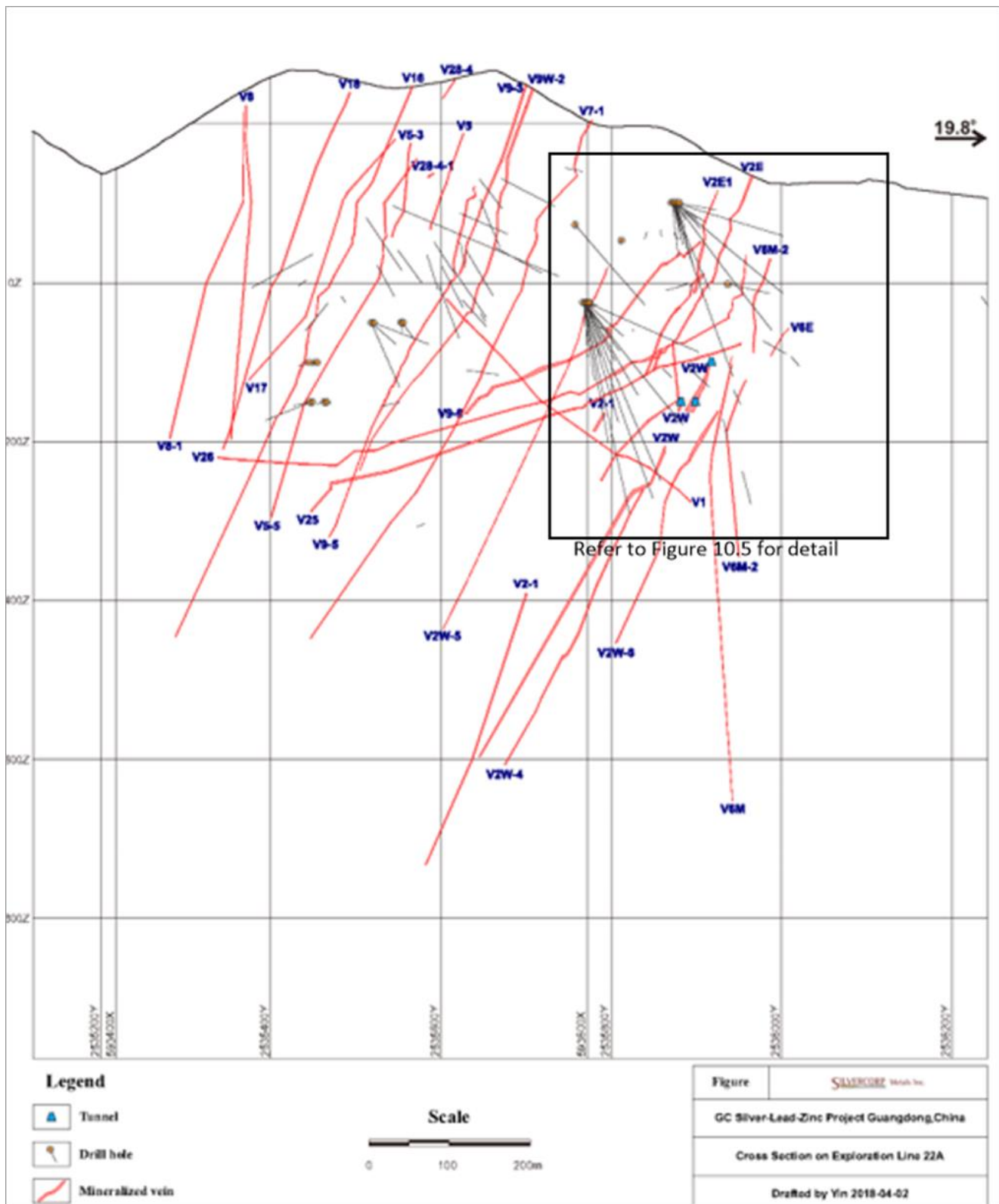

Source: Silvercorp Metals Inc.

Figure 10.5 Inset map for Cross Section 22A

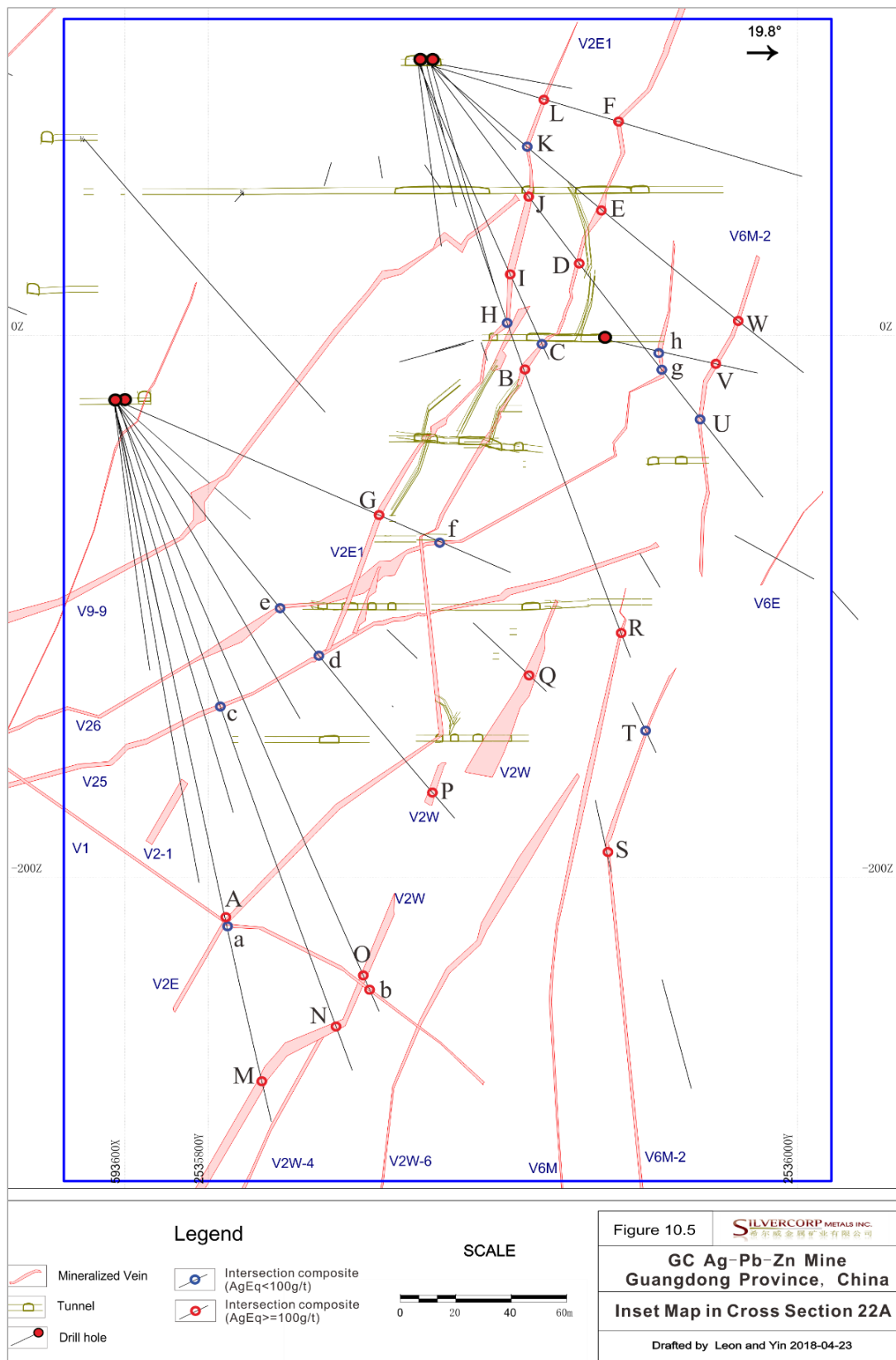

Source: Silvercorp Metals Inc.

Table 10.4 Drillhole intersections highlighted on Figure 10.5

Figure 10.5 point	Vein	Hole ID	From (m)	To (m)	Horizontal width (m)	Interval length (m)	Ag (g/t)	Pb (%)	Zn (%)	Ag Eq (g/t)
A	V2E	CK2316	195.17	197.17	1.12	2.00	43	3.2	4.2	366
B	V2E	CK2305	116.38	119.63	2.07	3.25	349	0.7	1.8	455
C	V2E	CK2307	111.50	112.55	0.72	1.05	3	0.1	0.1	13
D	V2E	CK2303	92.68	93.73	0.93	1.05	45	0.3	5.5	298
E	V2E	CK2302	79.82	83.02	3.18	3.20	109	3.0	4.1	420
F	V2E	CK2301	71.68	73.28	1.56	1.60	146	3.0	3.4	430
G	V2E1	CK2311	100.63	102.83	1.61	2.20	176	2.0	3.1	403
H	V2E1	CK2305	98.78	105.20	3.32	5.22	5	0.03	0.04	8
I	V2E1	CK2307	80.65	85.12	3.08	4.47	72	2.8	2.2	291
J	V2E1	CK2303	57.03	60.04	2.65	3.01	40	0.7	1.8	150
K	V2E1	CK2302	44.69	46.18	1.48	1.49	10	0.1	0.5	38
L	V2E1	CK2301	44.70	45.75	1.03	1.05	19	0.3	5.3	266
M	V2W	CK2316	258.10	262.76	2.61	4.66	11	0.5	1.6	103
N	V2W	CK2315	250.80	252.75	0.80	1.95	48	2.0	5.5	377
O	V2W	CK2313	210.03	212.93	2.10	2.90	45	1.1	3.6	250
P	V2W	CK2317	180.21	184.27	1.29	4.06	102	3.3	4.3	433
Q	V2W	CK2217	154.89	160.20	4.43	5.31	118	3.0	6.8	545
R	V6M	CK2305	218.64	219.49	0.54	0.85	91	0.2	0.6	126
S	V6M-2	CK2260	196.00	198.17	0.69	2.17	58	4.2	6.5	527
T	V6M-2	CK2259	172.36	173.18	0.18	0.82	28	0.2	0.3	49
U	V6M-2	CK2303	163.19	164.89	1.50	1.70	1	0.01	0.05	4
V	V6M-2	CK2266	38.21	39.76	1.40	1.55	67	0.2	1.8	152
W	V6M-2	CK2302	145.03	146.38	1.34	1.35	140	0.04	0.5	164
a	V1	CK2316	197.17	198.47	0.73	1.30	5	0.2	0.2	19
b	V1	CK2313	226.63	228.45	1.32	1.82	126	0.4	1.0	190
c	V25	CK2315	128.44	129.14	0.29	0.70	34	0.1	0.2	47
d	V25	CK2317	117.19	118.44	0.40	1.25	5	0.03	0.05	9
e	V26	CK2317	96.87	98.17	0.41	1.30	8	0.3	0.2	28
f	V26	CK2311	133.24	134.34	0.80	1.10	5	0.05	0.2	15
g	V26	CK2303	130.27	131.73	1.29	1.46	4	0.01	0.2	12
h	V26	CK2266	18.56	19.66	0.99	1.10	6	0.06	0.3	21

Source: Silvercorp Metals Inc.

Note: Ag equivalent is calculated using the equation $AgEq = 44.6 * Pb\% + 43.5 * Zn\% + Ag \text{ g/t}$.

Figure 10.6 Cross section on Exploration Line 34

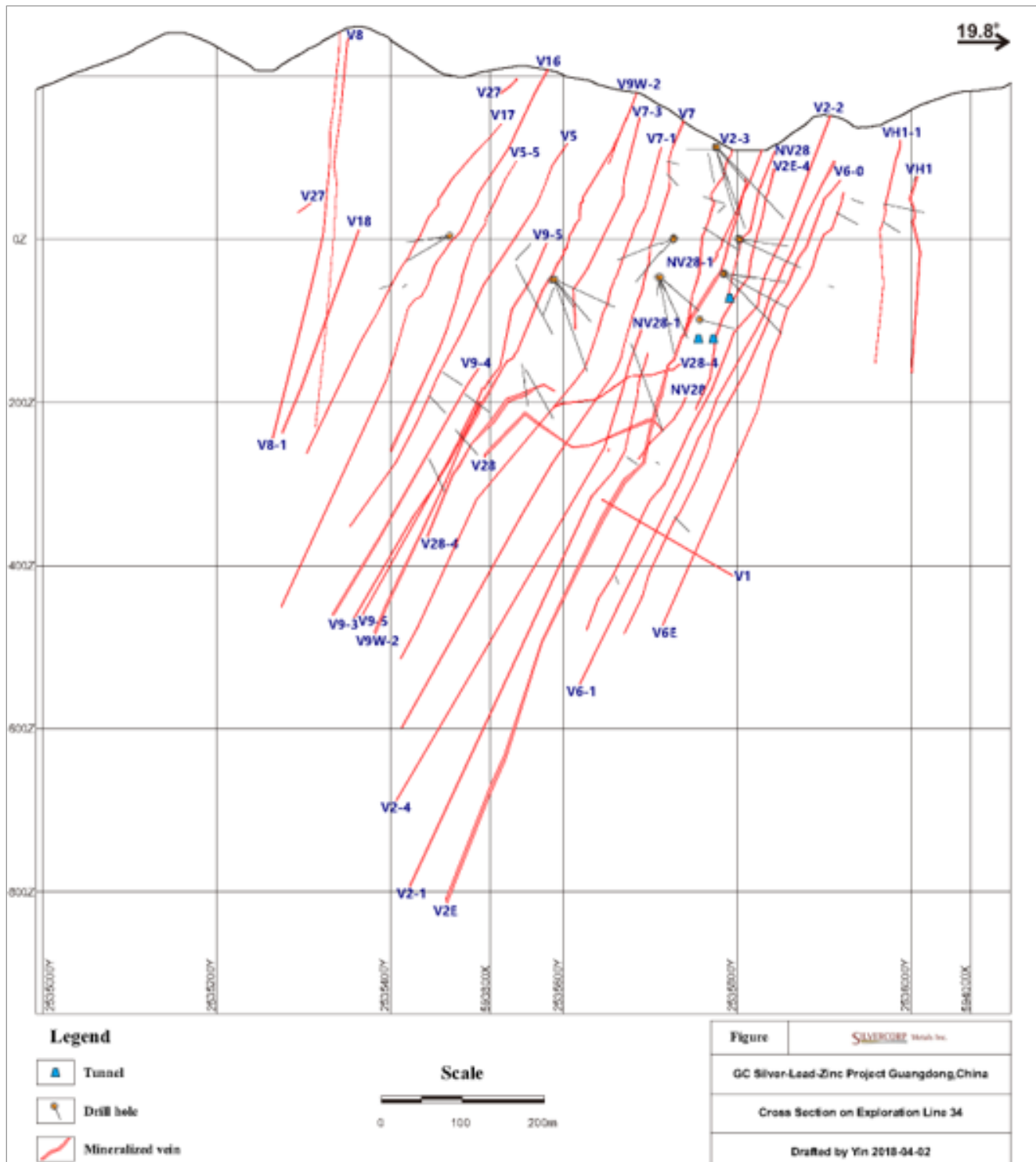

Source: Silvercorp Metals Inc.

Figure 10.7 Longitudinal section of Vein 2E

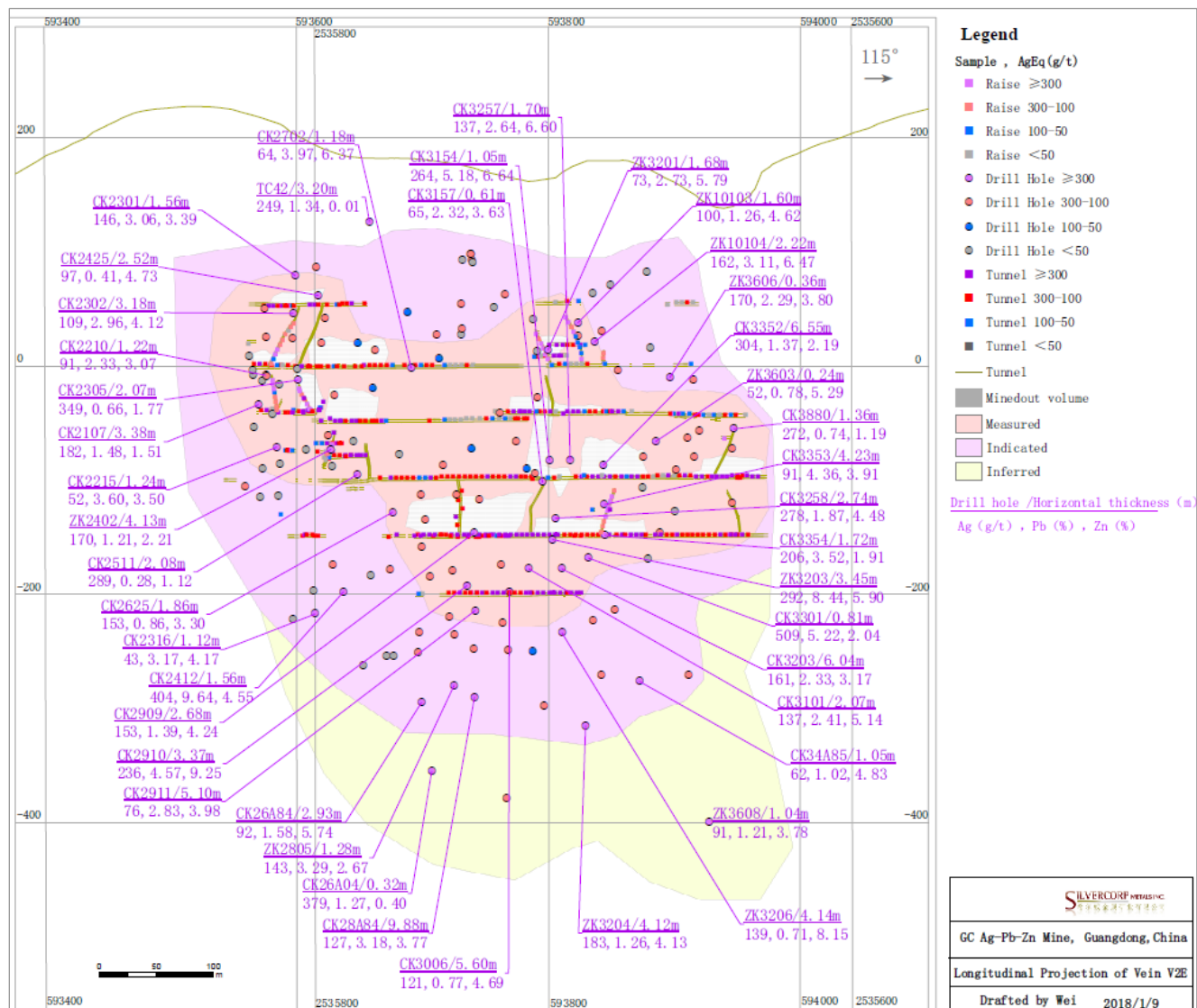

Source: Silvercorp Metals Inc.

10.2.3 Bulk density

A total of 62 samples from 21 drillholes were selected and sent to the Chinese government certified Guangdong Materials Test Centre in Guangzhou for bulk density testing using wax immersion. Samples selected ranged between 5 and 10 cm in length and between 470 and 2,690 g. Nine separate veins were tested.

Average bulk density for all samples after removal of outliers was calculated to be 3.57 t/m³. AMC noted that the average grade of the selected samples is around 65% higher than the average grade of the Mineral Resources, which raises the possibility that the average bulk density of 3.57 t/m³ may err on the high side.

AMC recommends that Silvercorp collect an additional 100 bulk density samples from representative veins of the deposit and of the varying base metal and pyrite contents. The average grade of bulk

density samples should reasonably approximate the average grade of the Mineral Resources. AMC also recommends that samples are assayed for total S in addition to Ag, Pb, and Zn.

If Silvercorp wishes to apply a minimum mining width to future GC Resource Estimates bulk density samples should also encompass bounding waste material.

10.3 Conclusion

In AMC's opinion there are no drilling, sampling or recovery factors that could materially impact the accuracy and reliability of drill results.

11 Sample preparation, analyses, and security

11.1 Introduction

This section describes the sampling methods, sample shipment and security, analytical techniques, and QA/QC followed during the 2008 – 2017 exploration programs. QA/QC data has been reviewed from the 2011 to 2017 drill programs. QA/QC data is not available for prior to 2011.

11.2 Sampling methods

11.2.1 Drillhole sampling

Drill core processing is completed by Guangdong Found employees in accordance with the following procedure:

- Geologists check metre marking and completeness of core at the drill site.
- Core is transported to the core shack at the surface in the camp complex.
- Geologists assess core recovery. This is completed by measuring the length of core recovered and comparing to the length of the drilled interval.
- Geologists complete detailed logging of core. Lithological, vein and mineralization contacts are identified and recorded. Angles to core axis are recorded for mineralized veins. Mineralized veins typically contain massive sulphide or significant quantities of sulphide and are visually distinct from non-mineralized wallrock.
- Geologists photograph and sample core.
- Drill core is sampled on 1.5 m maximum intervals and at geological or mineralization contacts
- Core is cut in half with a rock saw. One half is placed in a cotton bag which is labelled with the sample number. The other half is placed back in core tray for future reference.
- Sample bags are sealed.
- Individual samples are placed into rice bags and secured for shipment to the laboratory.

11.3 Underground sampling

Sampling of underground workings is completed by Guangdong Found employees as follows:

- Sampling of tunnels:
 - Channel samples are collected along sample lines perpendicular to the mineralized vein structure. Individual channel samples comprise a composite of chips comprising 5 m intervals across visible mineralization and increasing to 15 – 25 m across non-mineralized sections of the vein structure. Samples include vein material and associated wallrock.
- Cross cuts, tunnels, and bottom of trenches:
 - Channel samples are collected from walls of cross cut tunnels and bottom of trenches. In general, samples are limited to the thickness of the mineralized structure which can vary from 20 cm to 1.5 m wide.
- Samples are placed in a cotton bag which is labelled with the sample number. Sample bags are secured closed.
- Individual sample bags are placed into rice bags and secured for shipment to the laboratory.

11.4 Sample shipment and security

Samples were shipped from Gaocheng site to an ALS Laboratory in Guangzhou between 2008 and 2014. Commencing in 2012 Silvercorp shipped samples to the Gaocheng onsite laboratory in addition to ALS. GC became the primary laboratory in 2014. Samples were transported as follows:

- ALS Laboratories (2008 – 2014): Samples were transported in a pickup truck escorted by Guangdong Found employees and then couriered to ALS laboratories in Guangzhou.
- Gaocheng onsite laboratory (2012 – present): Samples are transported to the Gaocheng onsite laboratory escorted by a geologist from Guangdong Found.

11.5 Sample preparation and analysis

11.5.1 ALS Chemex Guangzhou

Between 2008 and 2014 samples were prepared and analysed by ALS Chemex in Guangzhou (ALS Guangzhou), Guangdong Province, China. ALS Guangzhou is accredited with International Standards Organization (ISO) 9001:2015 and China National Accreditation Service (CNAS). The accreditation covers General requirements for the Competence of Testing and Calibration Laboratories.

At ALS Guangzhou, samples were dried, and then crushed to greater than 70% passing <2 mm. The crushed sample was then split using a riffle splitter and up to 250 g pulverized to achieve 85% passing 75 microns.

Prepared samples were digested using ALS assay procedure ME-OG62. In the process samples are digested with nitric, perchloric, hydrofluoric and hydrochloric acids, evaporated, have hydrochloric acid and de-ionized water added, and then are heated for an allotted time. The cooled sample is then diluted to volume with de-ionized water, homogenized and analysed by inductively coupled plasma – atomic emission spectrometry (ICP-AES) or atomic absorption spectrometry (ICP-MS).

Detection ranges for ME-OG62 are shown in Table 11.1.

Table 11.1 ALS Chemex lab method and detection limits

Element	Symbol	Units	Lower limit	Upper limit
Silver	Ag	ppm	1	1,500
Lead	Pb	%	0.001	20
Zinc	Zn	%	0.001	30

Source: Compiled by AMC Mining Consultants (Canada) Ltd. from data provided by Silvercorp Metals Inc.

Silver samples returning assays greater than 1,500 g/t Ag were subsequently analysed by ALS fire assay (method AG GRA-21). This method has a lower detection of 5 g/t and an upper limit of 10,000 g/t.

11.5.2 Gaocheng Mine Laboratory

The Gaocheng Mine Site Laboratory (GC Lab) is owned and operated by Silvercorp. It is not certified by any standards association.

At the GC Lab, samples are dried for 12 hours at 75 – 80°C. Dried samples are crushed to 2 – 5 mm with a jaw crusher, then further crushed to 0.84 – 1.0 mm with a roll crushing machine. The crushed sample is split through a riffle splitter resulting in a subsample of 300 g. This sample is ground with a pulverizer made in Jiangxi, China to 0.125 – 0.074 mm. The pulverizer is cleaned regularly by grinding quartz sand, then cleaned with high pressure air.

Prepared samples (0.5 g) are digested using two acid digests. Ag, Pb, and Zn are analysed using atomic-absorption spectrometry (AAS). Detection limits for the GC Lab analytical process are:

Table 11.2 Silvercorp GC lab detection limits

Element	Symbol	Units	Lower limit	Upper limit
Silver	Ag	Ppm	1	500
Lead	Pb	%	0.001	3
Zinc	Zn	%	0.001	3

Source: Silvercorp Metals Inc.

Lead and zinc reporting above the detection limit (3%) are analysed using a separate titration process. This process has a lower detection limit of 2% and an upper detection limit of 80% for Pb and Zn.

Fire assay is used to analyse high grade silver. This process has an upper detection limit of 5,000 ppm Ag.

11.6 Data management

All data for the GC Project is stored within a central Microsoft Access Database (Access) which is managed by two designated database administrators. Drillhole data is collected in Microsoft Excel (Excel) and imported into the Access database. Underground mapping is recorded on grid paper and in Excel and then imported into Access or Micromine 3D software.

Data from the GC lab is loaded into Access as Excel files. AAS analyses are reported directly from the machine to Excel. Titrimetric analyses of Pb and Zn and gravimetric analyses of high grade silver samples are manually entered into Excel and then imported into Access.

11.7 QA/QC monitoring program – overview

Silvercorp has routinely inserted Certified Reference Materials (CRMs) since 2011. Blank (uncrushed) samples and coarse duplicates have been inserted since 2012 (drilling) and 2014 (underground sampling). Umpire samples (pulp duplicates) have been sent to a different laboratory since 2011. QA/QC insertion statistics are summarized in Table 11.3 and Table 11.4.

Table 11.3 QA/QC statistics

Year	Drilling					Underground sampling				
	Samples	CRMs	Blanks	Coarse duplicates	Umpire samples	Samples	CRMs	Blanks	Coarse duplicates	Umpire samples
Pre 2011	5496	0	0	0	0	2543	0	0	0	0
2011	1859	68	82	0	60	0	0	0	0	0
2012	4724	98	133	94	2247	1017	0	0	0	103
2013	7346	105	132	106	3094	108	0	0	0	11
2014	1592	44	50	44	109	2027	31	29	35	102
2015	1726	45	48	41	31	3934	64	67	68	0
2016	1930	82	81	80	33	4346	71	71	74	0
2017	4032	150	153	155	46	5085	84	84	84	0
Total	28705	592	679	520	5620	19060	250	251	261	216

Source: Compiled by AMC Mining Consultants (Canada) Ltd. from data provided by Silvercorp Metals Inc.

Table 11.4 QA/QC insertion rates

Year	Drilling					Underground sampling				
	Samples	CRMs	Blanks	Coarse duplicates	Umpire samples	Samples	CRMs	Blanks	Coarse duplicates	Umpire samples
Pre 2011	5496	0	0	0	0	2543	0%	0%	0%	0%
2011	1859	4%	4%	0%	3%	0	0%	0%	0%	0%
2012	4724	2%	3%	2%	48%	1017	0%	0%	0%	10%
2013	7346	1%	2%	1%	42%	108	0%	0%	0%	10%
2014	1592	3%	3%	3%	7%	2027	2%	1%	2%	5%
2015	1726	3%	3%	2%	2%	3934	2%	2%	2%	0%
2016	1930	4%	4%	4%	2%	4346	2%	2%	2%	0%
2017	4032	4%	4%	4%	1%	5085	2%	2%	2%	0%
Total	28705	2%	2%	2%	20%	19060	1%	1%	1%	1%

Source: Compiled by AMC Mining Consultants (Canada) Ltd. from data provided by Silvercorp Metals Inc.

11.8 Certified reference materials

11.8.1 Description

Four CRMs have been used by Silvercorp since 2011 (Table 11.5). CRMs GSO-2, GSO-4, and GBW07173 have been sourced from The Institute of Geophysical and Geochemical Exploration and approved by the General Administration of Quality Supervision, Inspection and Quarantine of the People's Republic of China. CRM CDN-FCM-7 has been sourced from CDN Resource Laboratories Ltd in Langley, BC, Canada.

Table 11.5 GC Certified Reference Materials

CRM ID	In use	Ag expected value (g/t)	Ag measure of variation (g/t) (notes 1, 2)	Pb expected value (%)	Pb measure of variation (%) (notes 1, 2)	Zn expected value (%)	Zn measure of variation (%) (notes 1, 2)
GSO-2 (GBW07163)	2011 - 2017	220	±10	2.17	±0.07	4.26	±0.15
GSO-4 (GBW07165) (note 3)	2011 - 2013	148	±6	5.13	±0.08	13.90	±0.20
GBW07173	2011	92	±11	2.14	1.97-2.17	6.06	±0.29
CDN-FCM-7 (note 3)	2013 - 2017	64.7	±4.1	0.629	±0.042	3.85	±0.19

Source: Compiled by AMC Mining Consultants (Canada) Ltd. from data provided by Silvercorp Metals Inc.

Notes: For GSO-2, GSO-4 and GBW07173, measure of variation = $t_{0.01} \times s / N$, where "t0.01" is the listed value of the Student's Distribution at the 99% confidence level, "s" the standard deviation and "N" the number of data sets used.

For CDN-FCM-7, measure of variation = two standard deviations.

GSO-4 was replaced with CDN-FCM-7 in 2013 because of its purported poor performance.

Since GSO-4 was replaced with CDN-FCM-7 in 2013 and GBW07173 was only used five times, in August 2011, GC has effectively only used two CRMs, GSO-2 and CDN-FCM-7, in recent years.

The CRM insertion rate for drillhole sample batches has been in the range of 3 – 4% in the last four years, and for underground chip sample batches has been around 2%. AMC understands that CRM performance at GC has not, to date, been monitored on a batch by batch basis, and Silvercorp was unable to provide AMC with control charts compiled at the time of assaying.

11.8.2 AMC discussion

CRMs are inserted to check the analytical accuracy of the laboratory. AMC advocates an insertion rate of at least 5% of the total samples assayed. CRMs should be monitored on a batch by batch basis and remedial action taken immediately if required. For each economic mineral, there should be at least three CRMs with values:

1. At around the cut-off grade of the deposit.
2. At the expected grade of the deposit.
3. At a higher grade.

The average Mineral Resource grades for the GC deposit are approximately 3% Zn, 1.3% Pb, and 110 g/t Ag at a 100 g/t AgEq cut-off grade. GSO-2 fits the criteria for a high grade CRM, but CDN-FCM-7 does not fit the criteria for either a CRM at around the cut-off grade of the deposit (100 g/t AgEq cut-off grade would equate to approximately 60 g/t Ag, 0.5% Pb, and 0.5% Zn) or the expected grade of the deposit.

CRM performance is typically monitored using control charts, examples of which are shown in Figure 11.1 to Figure 11.6. The performance of the CRMs is usually measured against the standard

deviation values that are provided with most commercially-produced CRMs. AMC advocates re-assaying assay batches with two consecutive CRMs occurring outside two standard deviations, or one CRM occurring outside three standard deviations.

The Chinese CRMs used at GC report a value of "uncertainty" rather than a standard deviation – see footnote to Table 11.5. AMC was unable to calculate the standard deviations from the information provided by Silvercorp, although it notes that the "uncertainty" limits for GSO-2 and GSO-4 are very tight, ranging from $\pm 1.4\%$ to $\pm 4.5\%$ of the certified values.

Based on CRM CDM-FCM-7 and six other Canadian Ag-Pb-Zn CRMs used by Silvercorp at its Ying operation, AMC has calculated that ± 2 standard deviations equate to approximately $\pm 5 - 6\%$ of the CRM certified value, and ± 3 standard deviations equate to approximately $\pm 8 - 9\%$ of the CRM certified value. In its assessment of the performance of the Chinese CRMs, AMC has used $\pm 5\%$ as a proxy for ± 2 standard deviations and $\pm 10\%$ as a proxy for ± 3 standard deviations¹.

Results of CRMs using AMC fail criteria are presented in Table 11.6.

¹ This is also consistent with an approach described by Coombes (2008) to assess CRM performance, in which CRMs 10% higher, and 10% lower than the expected values are considered to have failed.

Table 11.6 AMC CRM review statistics (all elements combined, 2011 – 2017)

CRM	Number of assays		AMC fails (>3 SD or >10%)		AMC mis-labelled		AMC true fails	
	Drilling	Underground	Drilling	Underground	Drilling	Underground	Drilling	Underground
GSO-2 (GBW07163)	312	128	0	0	0	0	0	0
GSO-4 (GBW07165)	77	0	1*	0	0	0	1	0
GBW07173	5	0	0	0	0	0	0	0
CDN-FCM-7	198	122	3**	0	3**	0	0	0

Source: Compiled by AMC Mining Consultants (Canada) Ltd. from data provided by Silvercorp Metals Inc.

Note: * Ag fail, ** Ag, Pb and Zn failed.

AMC's control charts for CRMs GSO-2 and CDN-FCM-7, submitted with drillhole samples, are presented in Figure 11.1 to Figure 11.6. Although not shown, control charts for underground chip samples show similar results and trends.

Figure 11.1 Control chart for GSO-2, Ag, drillhole samples

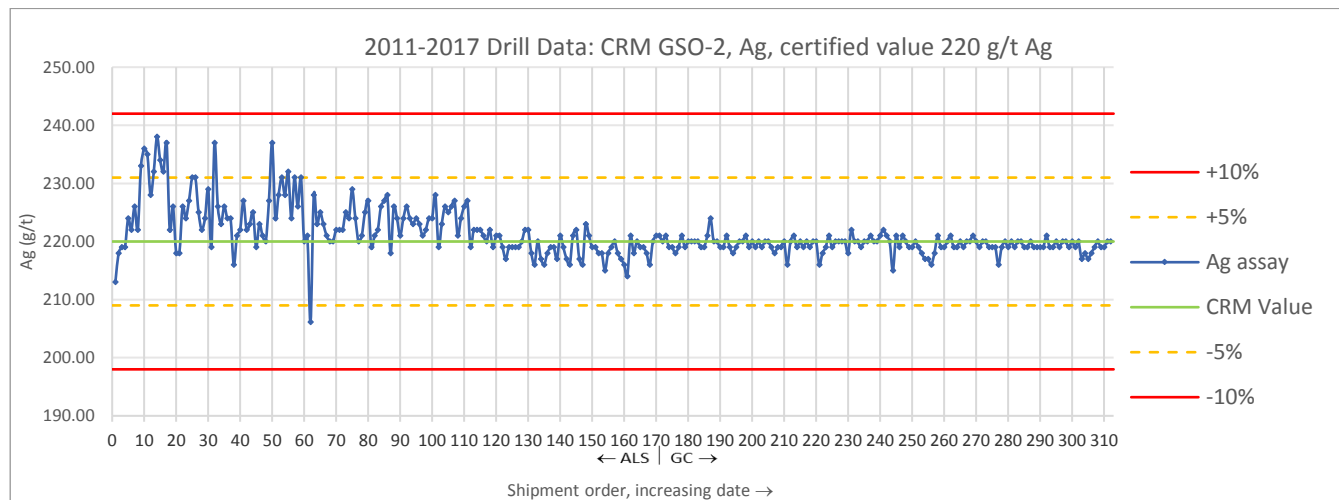

Source: Compiled by AMC Mining Consultants (Canada) Ltd. from data provided by Silvercorp Metals Inc.

Figure 11.2 Control chart for GSO-2, Pb, drillhole samples

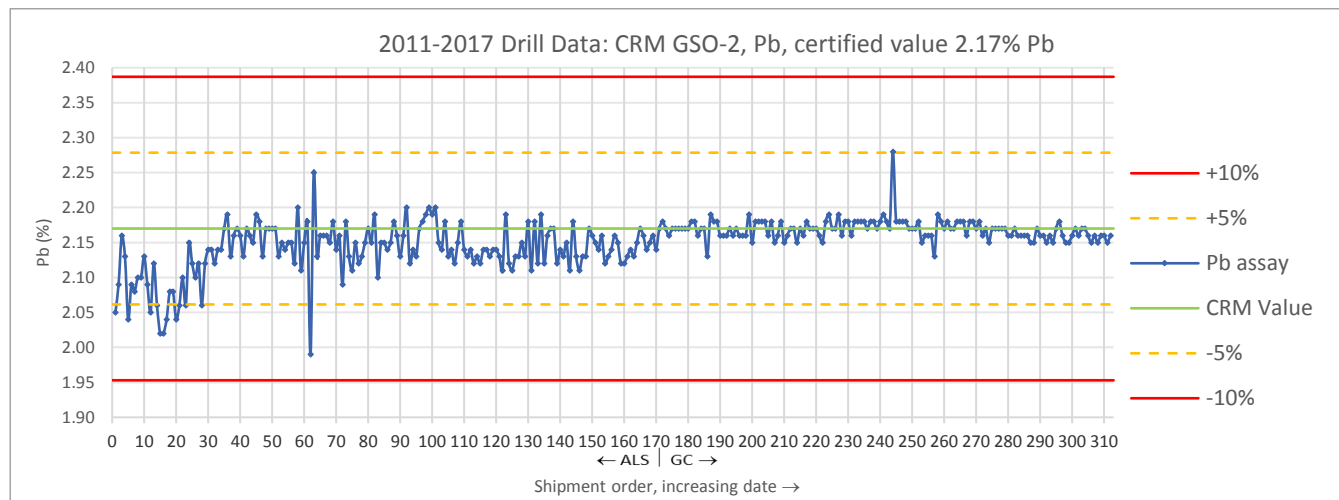

Source: Compiled by AMC Mining Consultants (Canada) Ltd. from data provided by Silvercorp Metals Inc.

Figure 11.3 Control chart for GSO-2, Zn, drillhole samples

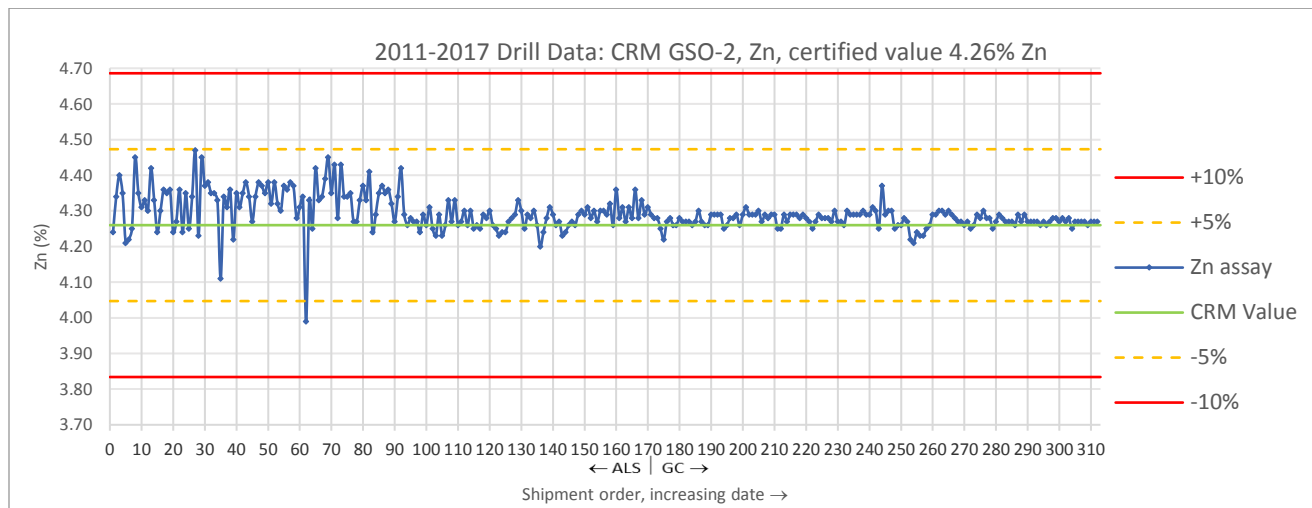

Source: Compiled by AMC Mining Consultants (Canada) Ltd. from data provided by Silvercorp Metals Inc.

Figure 11.4 Control chart for CDN-FCM-7, Ag, drillhole samples

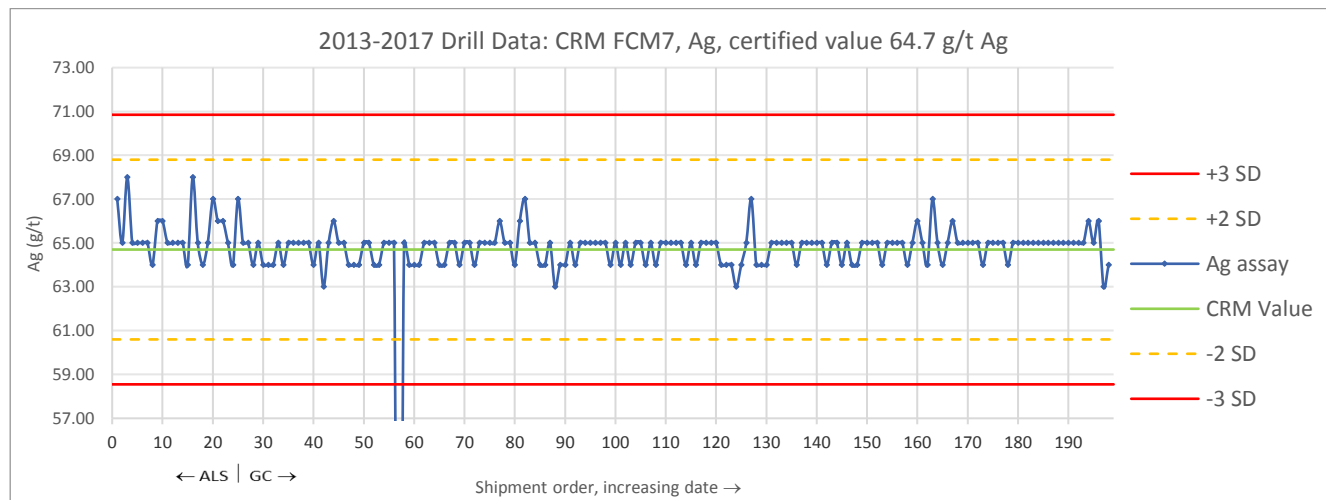

Source: Compiled by AMC Mining Consultants (Canada) Ltd. from data provided by Silvercorp Metals Inc.

Figure 11.5 Control chart for CDN-FCM-7, Pb, drillhole samples

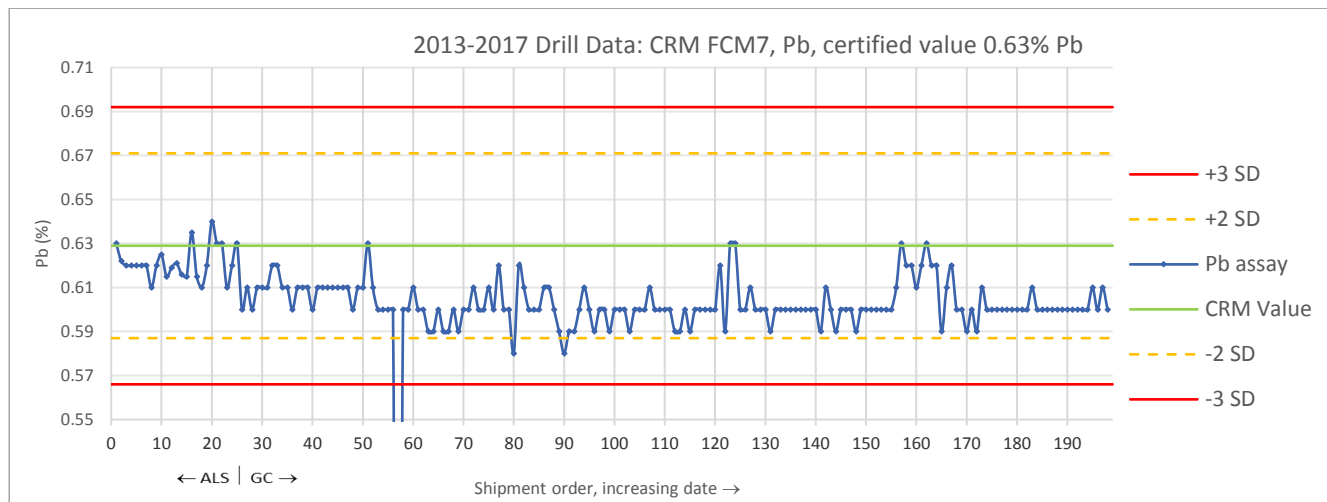

Source: Compiled by AMC Mining Consultants (Canada) Ltd. from data provided by Silvercorp Metals Inc.

Figure 11.6 Control chart for CDN-FCM-7, Zn, drillhole samples

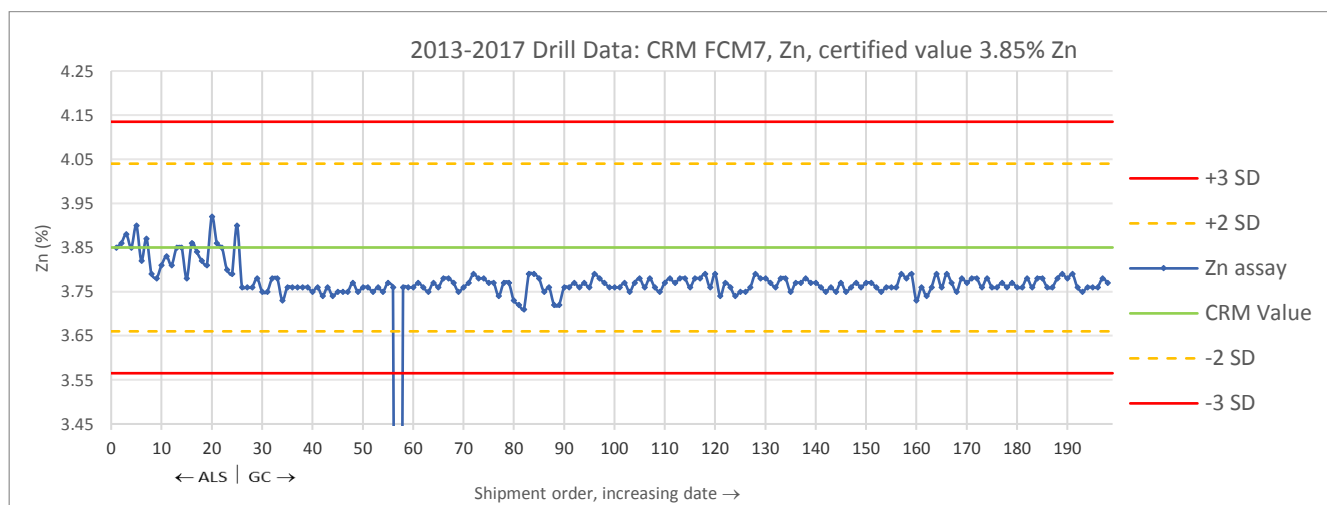

Source: Compiled by AMC Mining Consultants (Canada) Ltd. from data provided by Silvercorp Metals Inc.

11.8.3 AMC conclusions

- Subject to the caveats discussed below, CRM results have generally confirmed the reasonable analytical accuracy of the laboratories used.
- There was an improvement in CRM performance when the primary lab changed from ALS to GC.
- The notably precise and accurate performance of the GC lab with respect to GSO-2 raises concerns that the lab may be aware of the expected values of the CRM, which diminishes its usefulness as a blind check.
- There is a similar concern with respect to the GC lab and CDN-FCM-7, although the consistently 2 – 3% low bias shown for the lead and zinc CRM assays, while not of material concern to Mineral Resource estimates, suggests that the lab may believe the certified values to be less than their true values (0.60% Pb instead of 0.63% Pb, and 3.75% Zn instead of 3.85% Zn).

- The use in recent years of only two CRMs, GSO-2 and CDN-FCM-7, falls short of common industry practice, which is to use at least three (refer to 11.8.2 above) and preferably more.
- GSO-2 fits the criteria for a high grade CRM, but CDN-FCM-7 does not fit the criteria for either a CRM at around the cut-off grade of the deposit or around the expected grade of the deposit.
- The lack of real-time monitoring of CRM performance is of concern as it can lead to remedial action not being undertaken in a timely manner.
- If Silvercorp intends to keep using Chinese CRMs, it should require that standard deviation data be provided so that monitoring can be undertaken in accordance with common industry practice.
- The CRM insertion rate in recent years of 3 – 4% with drillhole sample batches and 2% with underground chip sample batches is less than the preferred rate of at least 5%.
- The above conclusions point to the need for an overhaul of the CRM program at GC.

11.8.4 AMC recommendations

- Institute an overhaul of the CRM program at GC as follows:
 - Purchase five additional commercially-produced CRMs, one high grade, two at around the cut-off grade of the deposit and two at around the expected grade of the deposit (note that having CRMs with similar, but slightly different values, reduces the chances of the laboratory recognizing them).
 - If Silvercorp intends to keep using GSO-2, require the Institute of Geophysical and Geochemical Exploration to provide the standard deviation data.
 - Introduce real-time monitoring of CRM results on a batch by batch basis.
 - Re-assay sample batches with two consecutive CRMs occurring outside two standard deviations, or one CRM occurring outside three standard deviations.
 - Increase insertion rates to at least 5%.
- Investigate the consistent negative biases apparent in the lead and zinc assays for CDN-FCM-7, to determine if they indicate real negative biases for the corresponding sample batches or arise from the GC lab recognizing the CRMs and assuming incorrect certified values.

11.9 Blank samples

11.9.1 Description

Silvercorp uses a Carboniferous dolomitic limestone from a local source as a blank material. The blank is inserted as large cobble sized fragments of rock (i.e. no crushing) collected by geologists from a quarry site. This source has not been subjected to detailed analytical testing or certification.

Silvercorp inserted 679 blanks with drillhole samples between 2011 and 2017 and a further 251 blanks with underground chip samples between 2014 and 2017. Blank samples in recent years have represented 3 – 4% and 1 – 2% of drillhole and underground samples respectively.

Silvercorp considers blank samples with assay results greater than 30 g/t Ag, 0.3% Pb, or 0.3% Zn to have failed (it also uses these criteria at the Ying mine). Statistics on blank samples submitted by Silvercorp between 2011 and 2017 and the results of Silvercorp pass / fail parameters are presented in Table 11.7.

Table 11.7 Silvercorp blank statistics

Sample type	Total samples	# Ag fail (>30 g/t)	# Pb fail (>3%)	# Zn fail (>3%)
Drilling samples	679	0	0	2
Underground samples	251	0	0	2

Source: Silvercorp Metals Inc.

11.9.2 AMC discussion

Coarse and non-crushed blanks test for contamination during both the sample preparation and assay process. Blanks should be inserted in each batch sent to the laboratory. In AMC's opinion, the "pass" requirement should be that 80% of coarse blanks should be less than twice the detection limit. AMC considers Silvercorp's fail criteria of 30 g/t Ag, 0.3% Pb, and 0.3% Zn to be significantly too high, although it acknowledges that it is probably not a matter of material concern to Mineral Resource estimates.

Table 11.8 and Table 11.9 show the assay results from blank materials for drilling completed between 2011 and 2017 and the results of AMC's pass / fail parameters. ALS and GC laboratories are reviewed separately due to the differences in detection limits.

Table 11.8 Assay results for blank samples (ALS Chemex Guangzhou)

Element	Blank / fail	Grade	Number of samples		
			Drillhole	Underground	Total
Ag	Blank	0	344	0	344
	AMC fail level	>2 g/t	13	0	13
Pb	Blank	0	256	0	256
	AMC fail level	> 0.002%	101	0	101
Zn	Blank	0	85	0	85
	AMC fail level	>0.002%	272	0	272

Source: Compiled by AMC Mining Consultants (Canada) Ltd. from data provided by Silvercorp Metals Inc.

Note: Detection Limits: Ag = 1 g/t, Pb = 0.001%, Zn = 0.001%.

Table 11.9 Assay results for blank material (Gaocheng)

Element	Blank / fail	Grade	Number of samples		
			Drillhole	Underground	Total
Ag	Blank	0	321	248	569
	AMC fail level	>10 g/t	1	3	4
Pb	Blank	0	315	239	554
	AMC fail level	> 0.002%	7	12	21
Zn	Blank	0	313	235	548
	AMC fail level	>0.002%	9	16	25

Source: Compiled by AMC Mining Consultants (Canada) Ltd. from data provided by Silvercorp Metals Inc.

Note: Detection Limits: Ag = 5 g/t, Pb = 0.001%, Zn = 0.001%.

Figure 11.7 and Figure 11.8 show drill data results for lead and zinc respectively.

There are two features of Table 11.8, Table 11.9, Figure 11.7, and Figure 11.8 that merit comment:

4. The very marked difference in the AMC failure rates between the ALS and GC labs.
5. The very large number of AMC failures for the ALS lab.

AMC speculates that the differences may arise from ALS having inserted the blanks immediately after well-mineralized samples (which is good practice), a process that may not have been followed by the GC lab, except possibly in the early days of taking over sample preparation from ALS. It is also possible that the blank samples used by ALS had very low levels of mineralization, while those used by the GC lab have no mineralization, or that the ALS lab had poor equipment cleaning processes in contrast to the GC lab.

Although AMC does not believe this issue to be of material concern, the difference in performance between the two labs should be investigated, and reassurance sought that the GC lab is using the blanks in a manner consistent with good QA/QC procedures. Tests should also be undertaken on the source of the blanks to ensure that it is barren.

Figure 11.7 2011 – 2017 blank performance (Pb)

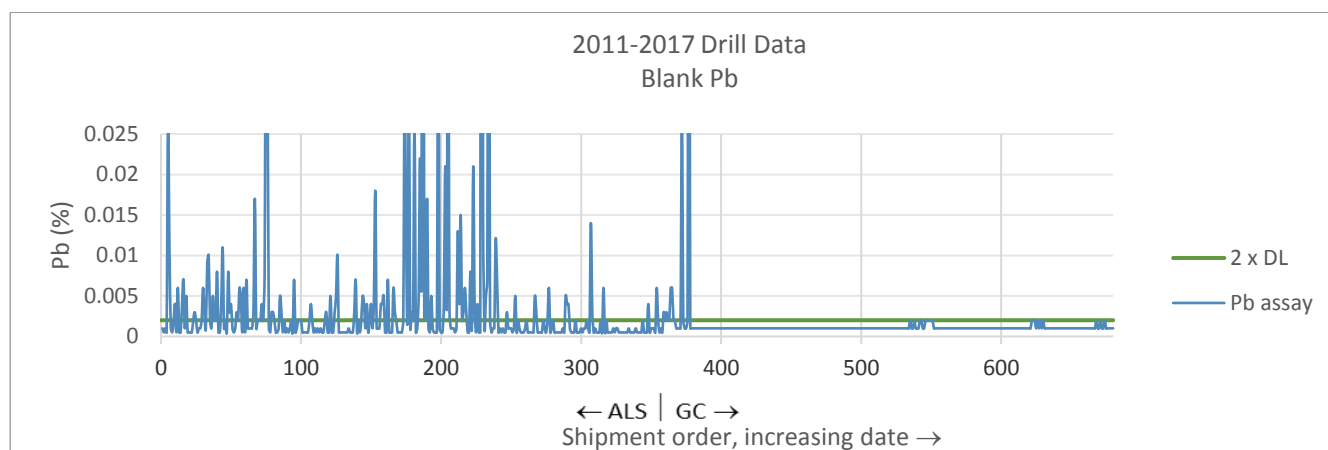

Source: Compiled by AMC Mining Consultants (Canada) Ltd. from data provided by Silvercorp Metals Inc.

Figure 11.8 2011 – 2017 blank performance (Zn)

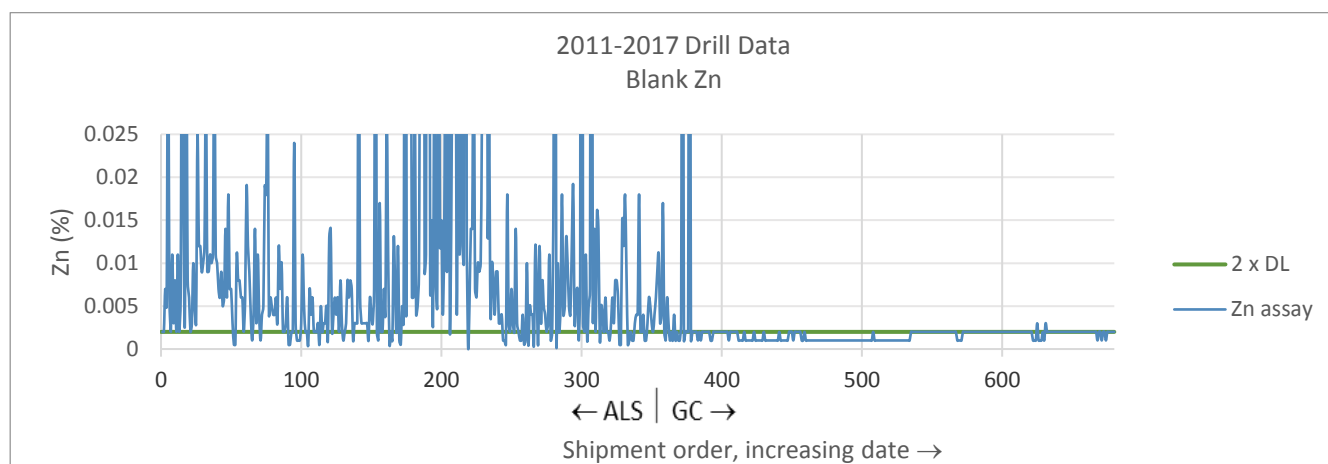

Source: Compiled by AMC Mining Consultants (Canada) Ltd. from data provided by Silvercorp Metals Inc.

11.9.3 AMC conclusions

- In house blank material used by Silvercorp has not been prepared or analysed to confirm that the material is un-mineralized.
- The blank failure parameters used by Silvercorp are generous and may not enable sample preparation / assaying contamination to be properly monitored. The parameters used by Silvercorp do not follow industry good practice.
- The very marked differences in performance between the ALS and GC labs should be investigated and reassurance sought that the GC lab is using the blanks in a manner consistent with good QA/QC procedures.
- The blank submission rate is less than desirable.

11.9.4 AMC recommendations

- Assay the source of the blank material to ensure its suitability as a blank.
- Substantially reduce Silvercorp's pass / fail criteria to conform with common industry practice.
- Investigate the very marked differences in performance between the ALS and GC labs and seek reassurance from the GC lab that it is using the blanks in a manner consistent with good industry practice.
- Increase blank insertion rates to at least 4% of samples submitted. Insert blanks immediately after expected high grade mineralization.
- Monitor blanks immediately upon receipt of results and have batches re-analysed if significant contamination is indicated.

11.10 Coarse duplicate samples

11.10.1 Description

Silvercorp has submitted coarse (uncrushed) duplicates regularly as part of its QA/QC program. Drillhole coarse duplicates comprise submission of ¼ core for selected samples. For underground samples, coarse duplicate samples have been collected as separate chip samples from the same location. Between 2011 and 2017 Silvercorp collected 520 ¼ core duplicate samples and 261 underground chip sample duplicates.

Silvercorp monitors coarse duplicates using scatter graph plots of the grades of original samples against the grades of the corresponding duplicate (Figure 11.9 A - F).

Figure 11.9 Scatter chart showing results of coarse duplicate samples, 2011 – 2017

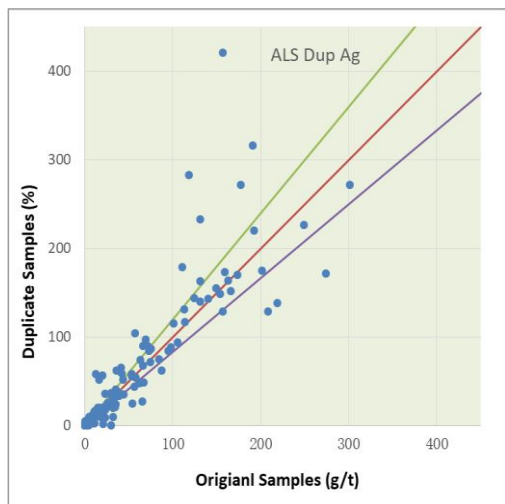

A – Ag Assay of coarse duplicates by ALS

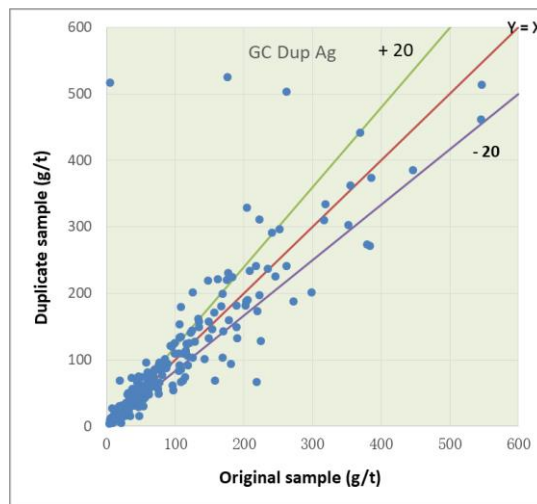

B – Ag Assay of coarse duplicates by GC Lab

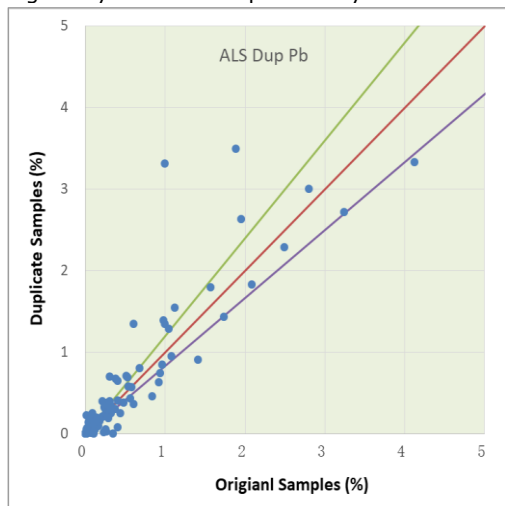

C – Pb Assay of coarse duplicates by ALS

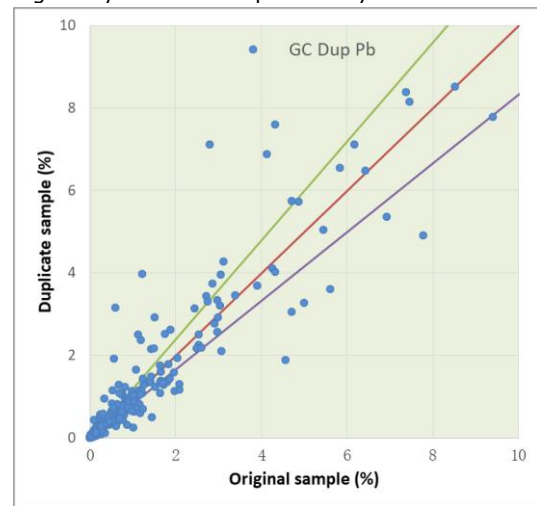

D – Pb Assay of coarse duplicates by GC Lab

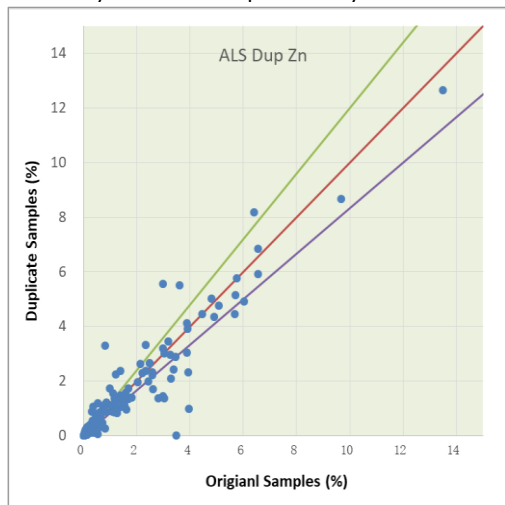

E – Zn Assay of coarse duplicates by ALS

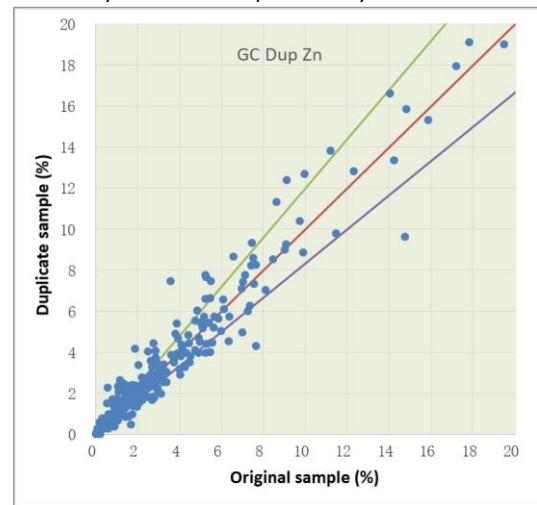

F – Zn Assay of coarse duplicates by GC Lab

Source: Silvercorp Metals Inc.

11.10.2 AMC discussion

Coarse, uncrushed duplicate samples monitor sampling variance (including that arising from crushing), analytical variance and geological variance.

Unmineralized samples should not be sent as duplicates because assays near the detection limit are commonly inaccurate. Duplicate data can be viewed on a scatterplot but should also be compared using the relative paired different (RPD) plot. This method measures the absolute difference between a sample and its duplicate. It is desirable to achieve 80 to 85% of the pairs having less than 20% RPD between the original assay and check assay if it is a coarse duplicate (Stoker, 2006). The results of RPD plots are presented in Table 11.10.

Table 11.10 Summary of RPD plots for Ag, Pb, and Zn for coarse duplicate samples

Element	% duplicates < 20% RPD	
	¼ core duplicates	Underground chip duplicates
Ag	59%	56%
Pb	46%	44%
Zn	53%	57%

Source: Compiled by AMC Mining Consultants (Canada) Ltd. from data provided by Silvercorp Metals Inc.

Sample pairs should be excluded from the analysis if the combined mean of the pair is less than 15 times the detection limit (Kaufman and Stoker, 2009) (see Table 11.11). Removing the low values ensures that there is no undue influence on the RPD plots due to the higher variance of grades likely near to the detection limit, where precision becomes poorer (Long et al., 1997).

Table 11.11 Coarse duplicate sample statistics

Element	Detection limit	Drillhole data		Underground data	
		Samples	Samples >15 times detection	Samples	Samples >15 times detection
Ag	1-5		190		109
Pb	0.001	520	437	261	245
Zn	0.001		501		260

Source: Compiled by AMC Mining Consultants (Canada) Ltd. from data provided by Silvercorp Metals Inc.

AMC makes the following observations based on the duplicate results:

- Between 46 and 59% of the quarter core duplicate pairs are less than 20% RPD, and duplicates report up to 5% higher grade.
- Between 44 and 57% of underground chip duplicates are less than 20% RPD, and duplicates report up to 6% lower grade.
- Although this performance is less than desirable, it is likely due to the heterogeneous nature of the mineralization, the uncrushed nature of the samples, and sampling variance.
- Less than half of Ag values are greater than 15 times the detection limit. The majority of Pb and Zn duplicate data are greater than 15 times the detection.

11.10.3 AMC conclusions

- The results of the coarse, uncrushed duplicate sample submission program does not raise any issues of material concern, with sub-optimal performance probably being due to the heterogeneous nature of the mineralization, the uncrushed nature of the samples, and sampling variance.
- Silvercorp could consider the introduction of crushed duplicates and pulp duplicates (replicates) as part of its QA/QC program to improve its monitoring of sample preparation and assaying performance.
- Silvercorp should conduct sieve analyses at various stages of sample preparation at the laboratory to ensure optimal parameters are achieved and minimal sampling errors are introduced.

11.10.4 AMC recommendations

- Consider the introduction of crushed duplicates and pulp duplicates (replicates) as part of the GC QA/QC program to improve monitoring of sample preparation and assaying performance.
- Conduct sieve analyses at various stages of sample preparation at the laboratory to ensure optimal parameters are achieved and minimal sampling errors are introduced.

11.11 Umpire (check lab) duplicate samples

11.11.1 Description

Silvercorp has been regularly submitting pulp duplicates to third party laboratories for independent analysis. Samples are selected evenly from the following Pb+Zn grade ranges:

- <1%
- 1% - 4%
- 4% - 10%
- 10 - 20%
- <20%

Silvercorp submitted 5,620 drillhole samples and 216 underground chip samples to umpire laboratories between 2011 and 2017. A number of laboratories have been involved (Table 11.12).

Table 11.12 Details of check assays

Year	Primary laboratory	Umpire laboratory	Drillhole check assays	Underground check assays
2011 – 2014	ALS Chemex	GC Laboratory	5,215	101
		BJ Laboratory	60	0
		Inner Mongolia Laboratory	123	115
		514 Laboratory	74	0
2014 – 2017	GC Laboratory	514 Laboratory	148	0
Total			5,620	216

Source: Compiled by AMC Mining Consultants (Canada) Ltd. from data provided by Silvercorp Metals Inc.

Umpire samples in recent years have represented 1 – 2% and 0% of drillhole and underground samples respectively. There appears to have been a major program of umpire sample submission in 2012/13, which Silvercorp has advised was related to commissioning of the GC laboratory.

Silvercorp monitors umpire duplicates using scatter graph plots and quantile-quantile (Q-Q) plots of the grades of original sample assay against the grades of the corresponding umpire sample assay (Figure 11.10 A – F).

Figure 11.10 Scatter charts showing results of umpire duplicate samples

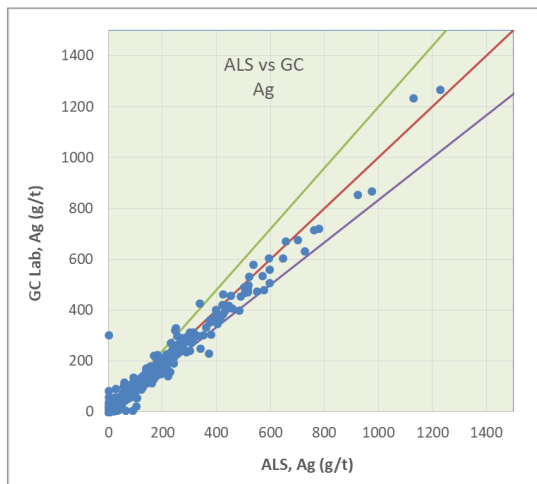

A – Ag Assay results of ALS vs. GC Lab

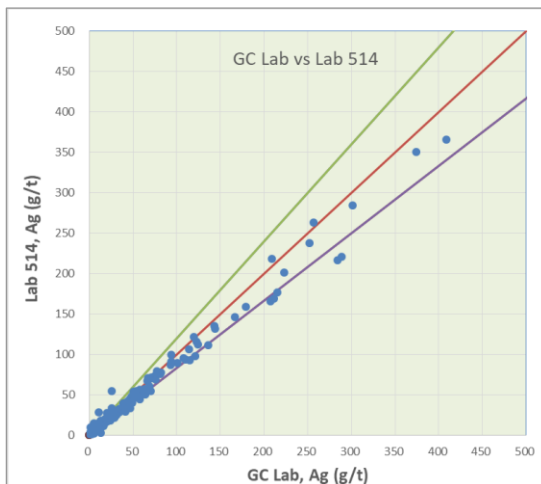

B – Ag Assay results of GC Lab vs. Lab 514

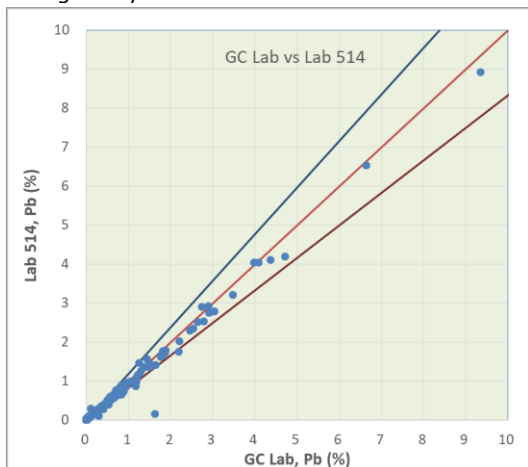

C – Pb Assay results of ALS vs. GC Lab

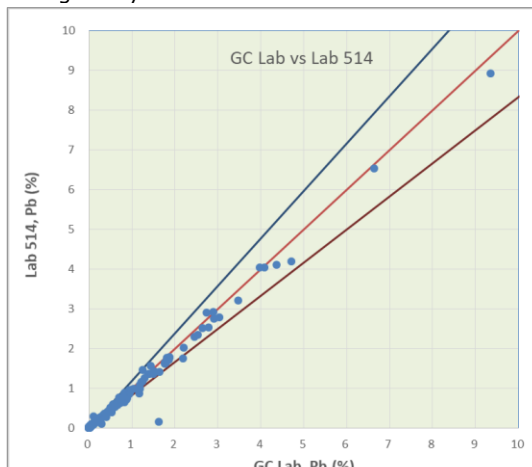

D – Pb Assay results of GC Lab vs. Lab 514

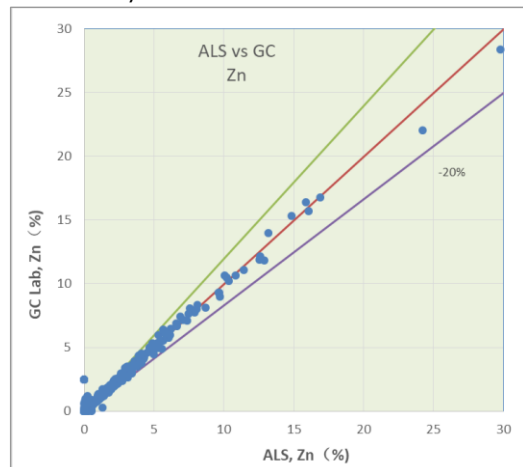

E – Zn Assay results of ALS vs. GC Lab

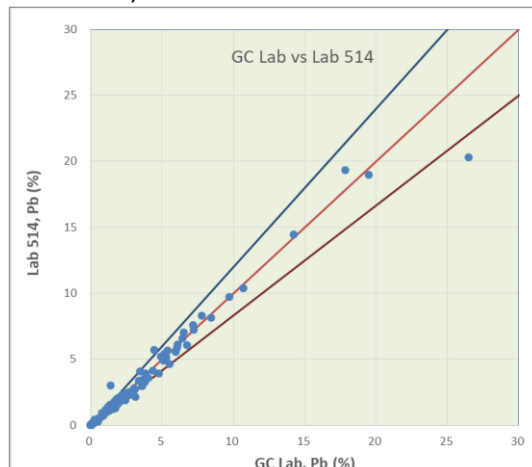

F – Zn Assay results of GC Lab vs. Lab 514

11.11.2 AMC discussion

Umpire laboratory duplicates are pulp samples sent to a separate laboratory to assess the accuracy of the primary laboratory (assuming the accuracy of the umpire laboratory). Umpire duplicates measure analytical variance and pulp sub-sampling variance. Umpire duplicates should comprise around 5% of assays. In AMC's opinion 80% of umpire duplicates should be within 10% RPD.

Results of umpire duplicates for ALS vs GC and GC vs 514 for drillhole samples are presented in Table 11.13.

Table 11.13 Results of umpire laboratory duplicates for drillhole samples

Element	% Umpire duplicates < 10% RPD		% Umpire duplicates < 20% RPD	
	Primary ALS Umpire GC	Primary GC Umpire 514	Primary ALS Umpire GC	Primary GC Umpire 514
Ag	68	53	85	79
Pb	58	55	87	80
Zn	56	70	83	94

Source: Compiled by AMC Mining Consultants (Canada) Ltd. from data provided by Silvercorp Metals Inc.

AMC makes the following observations on umpire laboratory duplicates for drillhole samples.

- Umpire laboratory duplicate submission rates have been somewhat variable since 2011 comprising up to 48% of assays during the commissioning of the GC lab in 2012 – 2013 and decreasing to 1% in 2017, which is well below acceptable rates.
- Between 53% and 70% of umpire duplicates are within 10% RPD of the original laboratory assay, which is sub-optimal but acceptable.
- Between 80% and 94% of umpire duplicates are within 20% RPD of the original laboratory assay, which is good.
- No systematic bias is observed between the original and umpire laboratories.

11.11.3 AMC conclusions

- Umpire laboratory duplicate submission rates have fallen well below acceptable levels in recent years.
- Based on RPD measurements, results have been sub-optimal but acceptable.
- No systematic bias is observed between the original and umpire laboratories.

11.11.4 AMC recommendations

- Increase umpire sample submission rates to around 5% for both drillhole and underground samples.

11.12 Conclusions

Silvercorp has implemented industry standard practises for sample preparation, security and analysis. This has included common industry QA/QC procedures to monitor the quality of the assay database, including inserting Certified Reference Material (CRM) samples, blank samples and coarse (uncrushed) sample duplicates into sample batches on a predetermined frequency basis. Umpire check duplicates samples have been submitted to check laboratories to confirm analytical accuracy.

AMC's review of Silvercorp's QA/QC procedures has highlighted a number of issues that require further investigation and improvement. AMC and Silvercorp have discussed these issues and agreed on a process to address and improve QA/QC.

AMC does not consider these issues to have a material impact on the global Mineral Resources and Mineral Reserve estimates but cannot guarantee there are no material impacts on a local scale. Overall, it considers the assay database to be acceptable for Mineral Resource estimation.

Refer also to Sections 11.8.3, 11.9.3, 11.10.3, and 11.11.3.

11.13 Recommendations

Refer to Sections 11.8.4, 11.9.4, 11.10.4, and 11.11.4.

12 Data verification

12.1 Site visit

On 23, 24, and 25 January 2018, AMC Principal Geologist Ms Dinara Nussipakynova, P.Geo., visited the Property to undertake the following verification steps:

- Discussions with site geologists regarding:
 - Sample collection
 - Sample preparation
 - Sample storage
 - QA/QC
 - Geological interpretation
 - Underground mapping procedures
- A review of the GC onsite laboratory.
- A review of underground workings.
- An inspection of the core shed and drill core intersections.

12.2 Assay data verification

Under supervision of Ms Nussipakynova, Simeon Robinson, P.Geo. of AMC undertook random cross-checks of assay results in the database with original assay results on the assay certificates returned from ALS Minerals and Silvercorp's onsite GC lab for Ag, Pb, and Zn. This verification included comparing 594 of the 11,171 assays contained within mineralized wireframes comprising drillhole and underground sampling data collected between 2008 and 2017. The results of data verification are presented in Table 12.1.

Table 12.1 Data verification results

Year	Samples within wireframe	# samples selected for verification	Assays confirmed	Error noted	Certificate not found	Total samples verified	% samples verified
pre 2012	2,417	151	136	0	15	136	6
2013	725	36	35	1	0	36	5
2014	1,287	71	70	1	0	71	6
2015	1,783	97	95	0	2	95	5
2016	2,091	104	98	4	1	103	5
2107	2,868	153	152	0	0	153	5
Total	11,171	612	586	6	18	594	5

12.3 Data validation

Data validation was carried out using the normal routines in Datamine where the database was checked for collar, survey, and assay inconsistencies, overlaps, and gaps.

12.4 AMC discussion

AMC makes the following observations based on the site visit and data verification.

- Site geologists are appropriately trained and are conscious of the specific sampling requirements of narrow vein, high-grade deposits.
- Six errors were noted out of 594 samples checked representing an error rate of 1.0%.
 - All errors identified were related to data entry:

- One instance where the assay results for the adjacent sample on the certificate was entered.
- Four instances where the sample prefix was omitted in the sample database and the incorrect assays loaded (e.g.: G169092 vs 169092).
- One instance where the sample number was entered incorrectly in the database and did not match the certificate (M890074 vs M89074).
- Pb and Zn (recorded as percent) are rounded to two decimal places in the GC database.
- Ag values (recorded as g/t) are rounded to nearest g/t.
- Assays reporting below detection limit are recorded at the detection limit.

12.5 Recommendations

AMC recommends that Silvercorp implement the following:

- Modification of the central database so that assay data be recorded without rounding to accurately reflect the original assay certificates.
- Internal validation of the existing sample database to ensure that any other sample prefix issues are addressed.
- A review of database and sample procedures to ensure that sample prefix issues do not reoccur.

12.6 Conclusions

AMC does not consider these issues to have a material impact on Mineral Resource estimates. The QP considers the assay database to be acceptable for Mineral Resource estimation.

13 Mineral processing and metallurgical testing

13.1 Introduction

This Section of the 2018 Technical Report includes a large part of the same section from the 2012 Technical Report titled 'NI 43-101 Technical Report on the GC Ag-Zn-Pb Project in Guangdong Province, People's Republic of China, effective date 31 December 2011'. Since the 2012 Technical Report no further metallurgical testing has been done but the mill has functioned in a trial mode up to 2014 and, from that point (FY2015 starting Q2 2014) has been in commercial production. The commentary below discusses metallurgical test work carried out prior to mill start-up, and results from actual processing operations. Further commentary on production operations is provided in Section 17.

Metallurgical testing for the GC project was carried out by the Hunan Research Institute of Non-Ferrous Metals and reported in May 2009 in the report "Development and Research of the Comprehensive Recovery Test of Lead Zinc Silver Tin Sulphur for the Lead Zinc Ore Dressing in GC Mine Area". This report was made available to AMC in English translation by Silvercorp. The testwork was summarized in the January 2011 GMADI report as part of the "Design Instructions" for the plant design; however, AMC drew on the original Hunan Institute report in preparing this section of the report.

The objectives of the testwork were, following on the previous testwork of 2007 on samples from artisanal mining dumps, to i) maximize silver recovery to the lead concentrate, ii) investigate the potential for tin recovery, iii) develop a process flow sheet with appropriate operating parameters as a basis for the industrial scale implementation of lead, zinc, sulphur (and possibly tin) recovery, iv) determine the product quality characteristics relative to the relevant national standards.

13.2 Metallurgical samples

The mineralization and vein structure has been well-summarized in this report and in the 2012 and 2009 Technical Reports. Figure 10.2 of this report shows the veins and drillhole locations.

For the purposes of assessing the representativeness of the metallurgical samples, the following was noted in the 2012 Technical Report:

- The samples derive from 152 drillhole intersections drilled along Lines 24 – 48, representing the central main cluster of veins.
- The main metal tonnage in the resource is contained in veins V2, V6, V7, and V10, although V6 is not as well represented in the reserve, presumably because of its depth.
- The high grade Ag-Pb-Zn shoots occur at the intersections of the WNW and E-W striking faults.
- The Zn mineralization is more pervasive; Ag and Pb are more locally concentrated but intensive, continuous and wide within the breccias zones of a fault.

The distribution of the metallurgical samples relative to the 2012 Mineral Reserve estimated tonnages and grades for the major veins was discussed in the 2012 Technical Report. The conclusion was made that the metallurgical sample grades approximated closely to the average reserve grades and, although vein V2 was somewhat under-represented, the weight distribution of the samples followed fairly closely the distribution by weight of the main veins that made up the 2012 Mineral Reserve.

Table 13.1 shows the average weight % metallurgical sample grades, 2012 Mineral Reserve grades from the metallurgical sample veins, and average mill head grades from FY2015 through to and including FY2018.

Table 13.1 Metallurgical samples relative to 2012 Mineral Reserve and FY2015 / 2018 mill head grades

Mineralization reference	Ag g/t	Pb %	Zn %
Met Samples average weight % grades	147	1.42	3.26
2012 Reserve grades metallurgical sample veins	114	1.28	2.85
Mill Head Grades FY2015 to FY2018	97	1.52	2.70

As can be seen from Table 13.1 the actual production mill head grades approximate closely to the average 2012 Reserve grades for silver and zinc but are closer to the metallurgical sample grades for lead.

13.3 Mineralogy

The sulphide mineralization is typical of mesothermal silver-lead-zinc-quartz-pyrite veins and has been described in general terms by O'Connor in previous Technical Reports. AMC previously noted that the sphalerite is described as having very fine inclusions of chalcopyrite and that this "diseased" sphalerite would promote general sphalerite flotation and inhibit selectivity against it in the lead (and copper) flotation.

The main focus of the Hunan Research Institute mineralogical work was on the silver department, relative to the projected importance of silver revenue.

The occurrence of silver is in three main forms, as summarized below together with the approximate weight distribution:

- Elemental silver, 23%.
- Silver sulphides, e.g. acanthite and argentite (both Ag₂S), 41%.
- Silver in sulphides i.e. as solid solution or inclusions, 33%.

In liberation terms, the principal elemental silver and silver sulphide associations are 13% free, 40% with galena, 14% with sphalerite and 30% with other sulphides, mainly pyrite, also pyrrhotite and arsenopyrite.

Of the silver in sulphides the occurrence is summarized in Table 13.2.

Table 13.2 Silver associations

Mineral	Wt %	Ag g/t	Ag % distribution
Galena	1.6	2897	46.2
Sphalerite	4.8	352	16.8
Other sulphides (pyrite, pyrrhotite, arsenopyrite)	16.7	207	34.5

These mineralogical results with the silver spread across the sphalerite and pyrite as well as the galena have implications for metallurgical performance. As silver is only paid in the lead concentrates, previously discussion referenced compromising lead concentrate grades (and zinc recovery) in order to maximize silver recovery to a payable (i.e. lead) concentrate. This is dealt with further in Section 13.4 in consideration of optimization of the process flowsheet. AMC also considered that the presence of elemental silver and silver sulphides would benefit from the use of a precious metal specific collector like a dithiophosphinate (e.g. Cytec 3418A) in addition to the standard dithiophosphate collectors used in the testwork.

The tin mineralogy was seen to be dominated by cassiterite (75%) with minor amounts of stannite (14%), tin in silicates (6%) and colloidal tin (5%). However, the granulometric distribution of the tin was noted as very fine (<75 µm) which does not augur well for effective gravity concentration.

13.4 Metallurgical testwork

AMC previously noted that no comminution testwork had been carried out so that no work index data or similar was available for grinding circuit design. Production operations have obviously superseded this commentary.

The prime focus of the flotation testwork was on lead (and therefore silver) recovery and both open circuit and closed circuit flotation tests were conducted to derive the final metallurgical performance predictions in line with normal practice. Some investigations into copper-lead separation and tin recovery were also carried out.

13.4.1 Lead flotation conditions

A series of rougher-scavenger flotation tests were performed to determine the optimum grind size, collector selection and dosage, and modifier regime. These were followed by kinetic rougher tests to determine the flotation residence time required.

Initial tests on various grind sizes ranging from 65% passing 75 µm to 90% passing 75 µm showed that, based on lead recovery and the silver grade in the lead concentrate, the optimum grind size was 80% passing 75 µm. AMC noted however that silver recovery was still increasing at finer sizes and investigations into regrinding the rougher concentrate could be warranted.

The basic chemical regime selected was based on lime for pH adjustment and pyrite depression with a combination of zinc sulphate and sodium sulphite for depressing sphalerite and a modest dosage of sodium sulphide to enhance flotation of any oxidized ores (note that an excess of sodium sulphide depressed lead). The use of cyanide in combination with zinc sulphate, the preferred combination in western complex sulphide flotation plants for sphalerite and pyrite depression, was not considered for environmental reasons.

Optimum rougher dosages were found to be:

- Lime 2,000 g/t
- Sodium sulphide 500 g/t
- Zinc sulphate 1,000 g/t
- Sodium sulphite 500 g/t

Based on this regime, investigations were carried out into the collector type and dosage from which it was concluded that the best results in terms of lead and silver recovery was a combination of a dithiocarbamate (AMC notes that this is more usually used for selective copper flotation) and a dithiophosphate at 25 g/t and 10 g/t respectively. AMC also noted that no tests were carried out with a precious metals specific collector of the type previously mentioned and considered this to be an improvement opportunity.

Conditions for cleaner flotation were determined to be 700 g/t lime and 400 g/t zinc sulphate with no further additions of sodium sulphide or sodium sulphite.

The kinetic rougher tests showed that a laboratory flotation time of 5 minutes was required (subject to the usual scale-up factors for industrial design).

13.4.2 Zinc and pyrite flotation conditions

Only limited testwork on zinc and pyrite flotation was carried out, based on the 2007 testwork and industry practice of copper sulphate as an activator and sodium iso-butyl xanthate (SIBX) under alkaline conditions as the collector for zinc flotation. This was followed by lowering the pH to 8 with sulphuric acid and flotation of the pyrite with more SIBX.

Acceptable zinc concentrate grades (52% Zn) at reasonable open-circuit recoveries and high pyrite recoveries were achieved.

13.4.3 Sulphide circuit flotation tests

Based on these conditions established for lead, zinc and pyrite flotation and with three stages of cleaning for lead and zinc flotation and one cleaner for pyrite flotation, a full open-circuit test of sulphide minerals flotation was conducted, as a proof of concept of the overall circuit.

A 48% Pb concentrate at 72% recovery was achieved; zinc recovery was lower (49%) to a 52% Zn concentrate with a substantial amount of the zinc tied up in lead circuit cleaner tails and scavenger concentrates that in practice would be recycled. The remainder of the sulphur was largely recovered to a 48% S pyrite concentrate.

This test demonstrated that sulphide flotation to saleable lead and zinc concentrates at acceptable (for batch tests) recoveries, and a high recovery of the balance of the sulphur to a pyrite concentrate was possible.

Determination of likely recoveries in an actual industrial scale flotation plant with recycling of intermediate "middlings" streams such as cleaner tails and scavenger concentrates was noted to require closed circuit flotation testing. This was carried out according to the flowsheet shown in Figure 13.1.

Figure 13.1 Closed circuit flotation test flowsheet

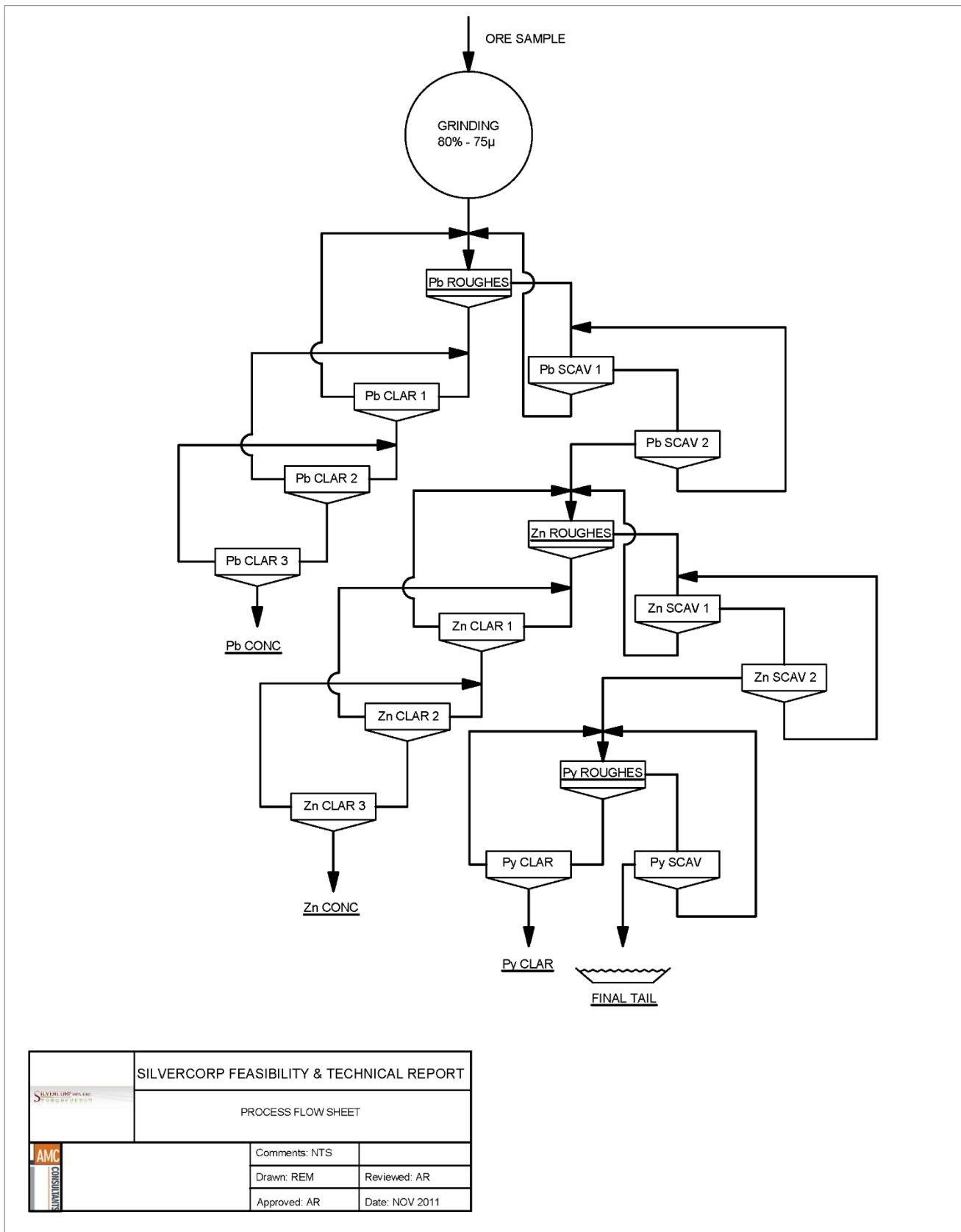

It was not clear to AMC from the testwork data and report of the extent to which this closed circuit test approached the locked cycle test standards commonly used in western laboratories. There was no information on how many cycles were performed (the usual minimum is six) and whether circuit stability was in fact achieved as the circulating loads of middling approached a sort of equilibrium. The most likely consequence of not attaining equilibrium was seen to be that concentrate grades may be over-estimated and recoveries under-estimated.

Notwithstanding this, the results as presented in Table 13.3 appeared reasonable and in accord with expectations from the mineralogy and experience of similar ores. These results constituted the design basis for the flowsheet and the 2012 Technical Report financial model.

Table 13.3 Closed circuit flotation test results

Product	Wt %	Grades				Recoveries			
		% Pb	% Zn	% S	Ag g/t	Pb	Zn	S	Ag
Pb Conc	2.63	46.35	9.53		3009	84.7	7.74		62.8
Zn Conc	5.84	0.92	48.95		268	3.73	88.2		12.4
Pyrite Conc	14.65	0.81	0.41	42.52	190	8.24	1.85	61.3	22.1
Tailings	76.88	0.06	0.09	0.53	4.5	3.38	2.18	4.01	2.74
Feed	100.0	1.44	3.24	10.16	126	100.0	100.0	100.0	100.0

13.4.4 Copper-lead separation tests

The closed circuit test produced a lead concentrate with 3% Cu; accordingly some preliminary investigations were carried out into producing separate copper and lead concentrates. No details of the experimental conditions were available, but the results showed that an 18.5% copper concentrate was produced at 67.6% recovery, but with 7.2% Pb and 16.6% Zn, not attractive to a smelter. The lead concentrate assayed 57.2% Pb at 89% recovery, with negligible copper levels. There was no information on silver deportment.

AMC understands that no further work has been done and no consideration given to incorporating a copper recovery circuit; AMC would consider that reasonable, given the results.

13.4.5 Tin recovery tests

Despite the low tin head grade and fine size distribution of the tin previously referred to, an extensive series of tests to recover tin was performed.

Attempts to produce a saleable grade tin concentrate through either froth flotation or centrifugal, enhanced gravity (high-g) devices were unsuccessful.

Finally, a concentrate of >50% Sn was obtained by spiral concentration followed by tabling of sized streams of the spiral concentrate then froth flotation on the table concentrate to remove the sulphides also concentrated by the gravity processes. Overall tin recovery from these batch tests was of the order of 30%. It was estimated that in a closed circuit tin recovery to a saleable concentrate would be 37%.

AMC considered that the concentrate grade was still relatively low but that if an appropriate smelter customer could be found a tin recovery circuit could in fact be potentially economically viable.

13.4.6 Optimization opportunities

It is AMC's experience with silver-lead-zinc concentrates that the optimum grade-recovery point for the lead concentrate is driven by maximizing silver recovery and is often at a surprisingly low lead

grade. This is particularly so in a fully integrated mine-concentrator-smelter operation and at higher silver prices.

As part of the 2012 Technical Report, AMC carried out a preliminary assessment of the optimization opportunity for moving to a lower grade point on the grade-recovery curve, referencing certain parameters. These are indicated below:

- Analysis of the open-circuit flotation test results to derive grade-recovery data for the lead concentrate and lead-zinc selectivity.
- Polynomial curve-fitting of this data to derive predictive formulae (relying on interpolation only, not extrapolation).
- Estimation from the flotation test data covering a range of lead and silver grades of the silver content of the lead concentrate at various lead grades (approx. 65 g/t Ag per 1% Pb).
- Calculation of the concentrate value at a range of concentrate grades from 30% to 60% Pb allowing for:
 - Incremental increases in silver recovery with increasing lead recovery (and lower lead grade).
 - Declining lead and silver payables as grade falls.
 - Zinc losses from the zinc concentrate to the lead concentrate (Zn non-payable).
- No allowance made for incremental transport costs (no data available).

The results of this exercise are summarized in Figures 13.2 and 13.3 below where two silver prices are considered, a 'longer-term' projection of US\$18/oz and a significantly higher price of US\$30/oz. Note that in both cases lead and zinc prices of US\$1.00/lb. were used.

Figure 13.2 Concentrate value vs % Pb (Ag \$18/oz)

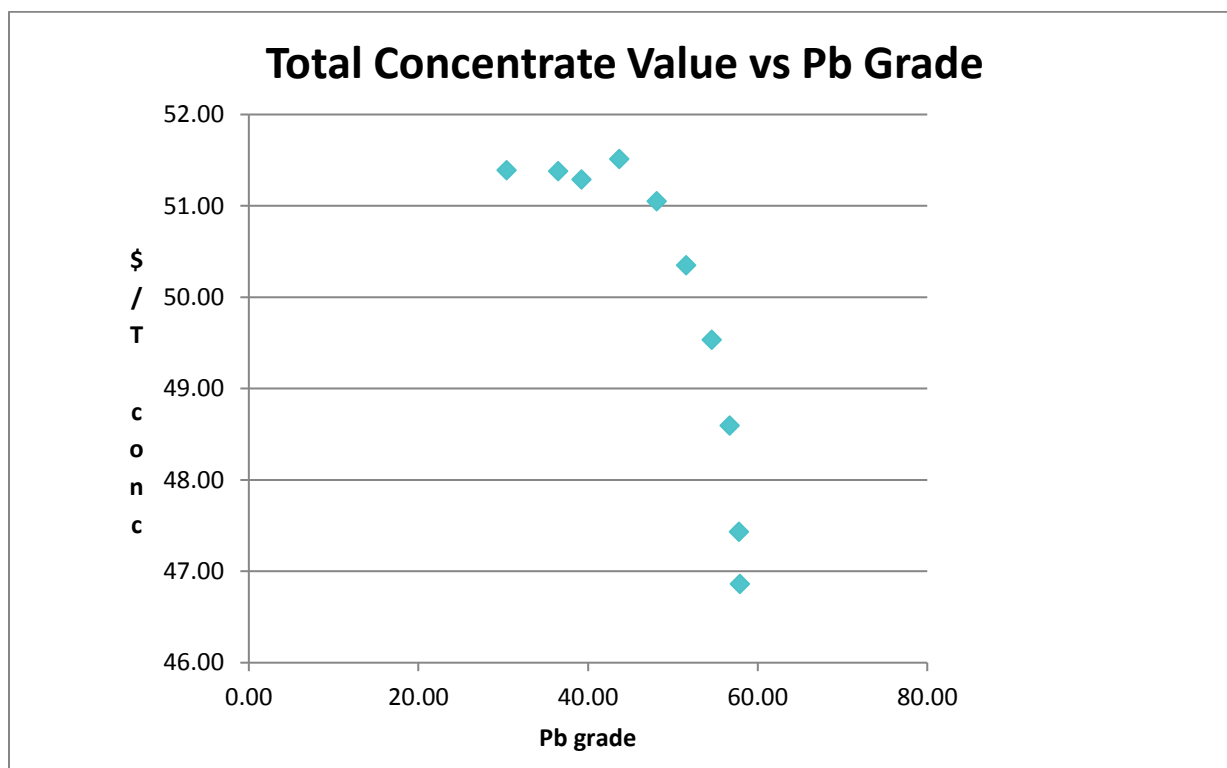
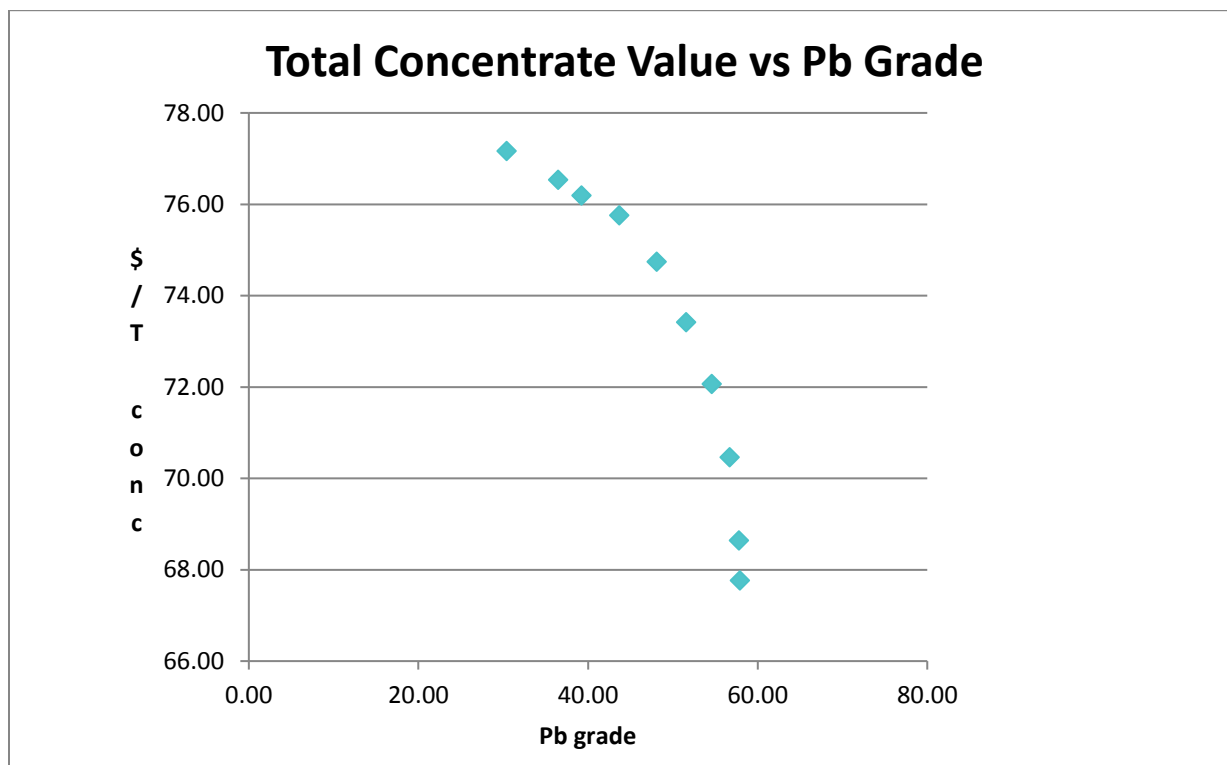

Figure 13.3 Concentrate value vs % Pb (Ag \$30/oz)



It is clear from the above graphs, and accepting the preliminary nature of the evaluation, that the optimum grade-recovery point is sensitive to silver prices. At the 'longer-term' price, the strategy targeting a lead concentrate grade of 46% Pb is seen to be close to the optimum of around 43%; however, a silver price of around US\$30/oz, and assuming lead and zinc prices around US\$1/lb, it would make more sense to pursue a strategy of maximizing lead and silver recovery, at the expense of zinc recovery and, within smelter contract constraints (min 35% Pb grade), lead concentrate grade. However, at current higher zinc prices, a strategy aimed at maximizing zinc value while maintaining as much as possible of the silver, then lead contribution would appear to be more appropriate.

13.5 Concentrate quality considerations

For the metallurgical testing, the main issues highlighted by GMADI with respect to concentrate quality relative to the national standards were:

- Copper and zinc levels in the lead concentrate (3% and 9% respectively), which AMC considered to be more of a commercial issue rather than a material quality issue.
- Arsenic levels in the zinc concentrate (0.57% As) which exceed the 0.4% As level for an otherwise clean Grade 3 concentrate.
- Arsenic levels in the pyrite concentrate (1.15% As) which exceed the 0.07% As level in the top category (Grade 1) of the standard.

AMC considered that the only potential quality issue was arsenic. Experience reported in operations indicates that the As level in the zinc concentrate has been maintained below 1% with, in most instances, a similar result for the pyrite concentrate. AMC also notes the Silvercorp concentrate selling arrangements whereby:

- Should the As level ever be higher than 1.0% in zinc concentrates, the payable Zn content would be discounted by 0.5% Zn for every 1% As above the 1.0% As level.
- For instances where the pyrite concentrate has an As content above 1.0%, a penalty is paid on a case by case basis.

13.6 Summary of testwork outcomes

The key outcomes of the metallurgical testwork were as follows.

13.6.1 Metallurgical samples

The metallurgical samples were adequately representative of the main part of the orebody and of the 2012 Mineral Reserves.

13.6.2 Mineralogy

The mineralogy is more challenging than Silvercorp's Ying mine in Henan province, mainly because the silver content is more widely spread across the mineral suite, i.e. in the sphalerite and pyrite as well as being of payable content in association with the galena.

13.6.3 Laboratory testwork

13.6.3.1 Grinding

No grinding testwork had been carried out at the time of the 2012 Technical Report. Although this would normally be a standard inclusion in any feasibility study, AMC made allowance to compensate for this deficiency in its discussion around process design.

13.6.3.2 Flotation

- Batch flotation tests established a workable set of flotation conditions and reagents although an opportunity was recognized to pursue the use of a precious metal specific collector like Cytac A3418A.
- Closed circuit flotation tests allowed derivation of reasonable predictions of concentrate grades and recoveries, as summarized in Table 13.4.

Table 13.4 Closed circuit flotation test results

Product	Wt %	Grades				Recoveries			
		% Pb	% Zn	% S	Ag g/t	Pb %	Zn %	S %	Ag %
Pb Conc	2.63	46.35	9.53		3009	84.7	7.74		62.8
Zn Conc	5.84	0.92	48.95		268	3.73	88.2		12.4
Pyrite Conc	14.65	0.81	0.41	42.52	190	8.24	1.85	61.3	22.1
Tailings	76.88	0.06	0.09	0.53	4.5	3.38	2.18	4.01	2.74
Feed	100.0	1.44	3.24	10.16	126	100.0	100.0	100.0	100.0

Note: Copper-lead separation not deemed commercially viable.

13.6.3.3 Tin recovery

Despite the fine grain size and resulting low gravity recoveries, a tin recovery circuit appended to the end of the main circuit was projected to be low cost and potentially viable.

13.6.4 Optimization opportunities

Relative to the high silver price environment of 2012, a recommendation was made that attention should be paid to increasing further the silver recovery even at the expense of a lower % Pb concentrate grade, and with smelter contracts to be negotiated accordingly.

13.6.5 Concentrate quality

Copper and zinc levels in the lead concentrate are a commercial rather than a material quality issue; however arsenic levels in the lead and zinc concentrates were previously seen to be potentially material and were seen as meriting further investigation. AMC now notes that GC lead and zinc concentrates are acceptable to the Chinese smelters with which Silvercorp has contracts (see Section 13.5 above).

13.7 Mill operation FY2015 to present

Table 13.5 is a summary of mill results since the start of commercial production in 2014 Q2 (start of FY2015). AMC has noted that the closed-circuit test work conducted to provide design data for the flotation circuit produced results that appeared reasonable in accordance with experience of similar ores. The mill was designed and constructed using these data.

The mill has consistently exceeded the lead closed-circuit test result of 85%; achieving 88.0% in FY2016. Lead concentrate grade has generally improved over the four years of operation, averaging 45.2% Pb in FY2018 versus the closed-circuit test value of 46%.

Zinc concentrate grade has not achieved closed-circuit test performance; averaging 82% recovery compared to the closed-circuit test performance of 88%, while producing concentrate with average grade of 45% versus the closed-circuit value of 49%.

Silvery recovery has consistently exceeded the closed-circuit value of 75.2%; averaging 76.2% for FY2018.

The sulphur recovery circuit has not performed as would have been predicted from the closed-circuit test work. Sulphur in circuit tailings has ranged from 3.28% S to 8.57% S while the closed-circuit test work achieved 0.53%. Sulphur recoveries as low as 25% have been achieved rather than 61.3% shown by the test work.

Table 13.5 Gaocheng mill performance FY2015 to FY2018

Fiscal year	FY2015	FY2016	FY2017	FY2018
Ore mined (tonnes)	253,321	257,575	260,746	245,783
Ore milled (tonnes)	261,315	256,861	260,696	244,338
Head grades				
Silver (g/t)	107	94	94	98
Lead (%)	1.35	1.76	1.44	1.45
Zinc (%)	2.65	2.53	2.81	2.78
S grade, %	9.29	9.19	10.55	10.40
Average metal grades of lead concentrate				
Ag g/t	1,947.50	1,589.03	1,729.77	1,984.44
Pb %	39.06	44.00	42.45	45.20
Average metal grades of zinc concentrate				
Ag g/t	511.13	420.73	389.28	395.96
Zn %	45.21	47.38	45.09	43.53
Sulphur concentrate and tailings				
S grade % in concentrate	47.71	49.70	49.48	49.40
Ag grade g/t in tailings	18.73	10.93	18.69	25.75
Pb grade % in tailings	0.14	0.13	0.14	0.17
Zn grade % in tailings	0.18	0.13	0.22	0.32
S grade % in tailings	5.43	3.28	3.90	8.57
Pb concentrate t	7,799	9,022	7,586	6,685
Zn concentrate t	12,355	11,354	13,760	12,746
S concentrate t	12,769	21,464	15,458	186
Tailings t	228,391	215,023	223,892	224,720
Ag recovered from lead concentrate kg)	15,189	14,336	13,122	13,266
Ag recovered from zinc concentrate (kg)				
Total Ag recovered (kg)	24,561.87	23,083.44	21,701.04	21,334.47
Pb recovered in lead concentrate (t)	3,047	3,970	3,220	3,021
Zn recovered in zinc concentrate (t)	5,585	5,379	6,205	5,548
S processed (t)	6,092	10,668	7,649	91.96
Recovery rates				
Silver recovered in lead concentrate (%)	53.63	59.22	53.73	55.17
Silver recovered in zinc concentrate (%)	23.30	19.70	21.90	20.99
Total Ag recovery rate (%)	76.93	78.92	75.63	76.16
Lead recovery (%)	86.25	88.00	85.74	85.42
Zinc recovery (%)	80.59	82.76	84.67	81.75
S recovery %	25.10	45.17	27.82	0.36

14 Mineral Resource estimates

14.1 Introduction

The Mineral Resource estimates for the GC deposit have been prepared by Mr Shiping Yin, Resource Geologist of Silvercorp. Ms Dinara Nussipakynova, P.Geol., of AMC, has reviewed the methodologies and data used to prepare the Mineral Resource estimates and, after some adjustment to the Mineral Resource classification, she is satisfied that they comply with reasonable industry practice. Ms Nussipakynova takes responsibility for these estimates.

AMC is not aware of any known environmental, permitting, legal, title, taxation, socioeconomic, marketing, political, or other similar factors that could materially affect the stated Mineral Resource estimates.

This estimate supersedes the previous estimate outlined in the "NI 43-101 Technical Report on the GC Ag-Zn-Pb Project in the Guangdong Province, People's Republic of China" dated 23 January 2012. The previously estimate had an effective date of 23 January 2012 and included drilling to 31 December 2010.

The data used in this report (effective date 30 June 2018) includes results of all drilling carried out on the Property to 31 December 2017.

The estimation was carried out in Micromine™ software. Interpolation was carried out using inverse distance cubed (ID³) for all the veins.

The result of the current estimate is summarized in Table 14.1.

Table 14.1 Summary of Mineral Resources as of 31 December 2017

Resource classification	Tonnes (Mt)	Ag (g/t)	Pb (%)	Zn (%)	Contained metal		
					Ag (koz)	Pb (Mlbs)	Zn (Mlbs)
Measured	2.735	101	1.4	3.2	8,840	84	195
Indicated	3.638	92	1.2	2.7	10,818	98	217
Measured and Indicated	6.374	96	1.3	2.9	19,658	181	412
Inferred	7.481	107	1.2	2.6	25,662	196	429

Notes: CIM Definition standards (2014) were used for reporting the Mineral Resources

Mineral Resource are reported at a cut-off grade of 100 g/t AgEq

The equivalency formula is $Ag\ g/t + 44.6 * Pb\% + 43.5 * Zn\%$ using prices of \$19/oz Ag, \$1.00/lb Pb and \$1.25/lb Zn and estimated recoveries of 77% Ag, 86% Pb, and 83% Zn.

Sample results up to 31 December 2017. Mineral Resources are inclusive of Mineral Reserves reported in Section 15.

Mineral Resources that are not Mineral Reserves do not have demonstrated economic viability.

The numbers may not compute exactly due to rounding.

Source: Silvercorp, reproduced as a check by AMC Mining Consultants (Canada) Ltd.

14.2 Data used

14.2.1 Drillhole database

The data used in the estimate consists of surface and underground diamond drillholes and channel samples. The underground channels consist of sampling tunnels, raises and crosscuts. Silvercorp maintains the drill and channel data in an Access database and provided the data to AMC in that format. The number of holes and number of assays used in the estimate, by year of drilling, are shown in Table 14.2.

Table 14.2 Summary of data used in 2018 estimation

Year	Trench			Underground channel			Surface drillhole			Underground drillhole		
	No	No. of samples	Length (m)	No	No. of samples	Length (m)	No	Metres samples	Length (m)	No	Metres samples	Length (m)
2002							3	94	680			
2005							3	85	972			
2006				12	1,115	3,674						
2007	7	69	304	18	72	90	20	1,456	6,853			
2008							22	1,980	10,083			
2011				2	4	2						
2012				179	554	643				222	5,904	33,706
2013				496	1,584	1,808	81	3,871	24,653			
2014				669	1,766	1,529				184	3,384	29,277
2015				1,152	2,959	2,121	17	586	4,510	180	3,336	29,997
2016				1,329	3,504	2,698				131	2,173	12,697
2017				1,550	4,415	3,137				187	4,973	25,132
Total	7	69	304	5,407	15,973	15,704	146	8,072	47,751	904	19,770	130,810

Notes: Drill data to 31 December 2017.

Numbers may not add due to rounding.

Source: Silvercorp, reproduced as a check by AMC Mining Consultants (Canada) Ltd.

Figure 14.1 3D view of GC drillholes and channels sampling

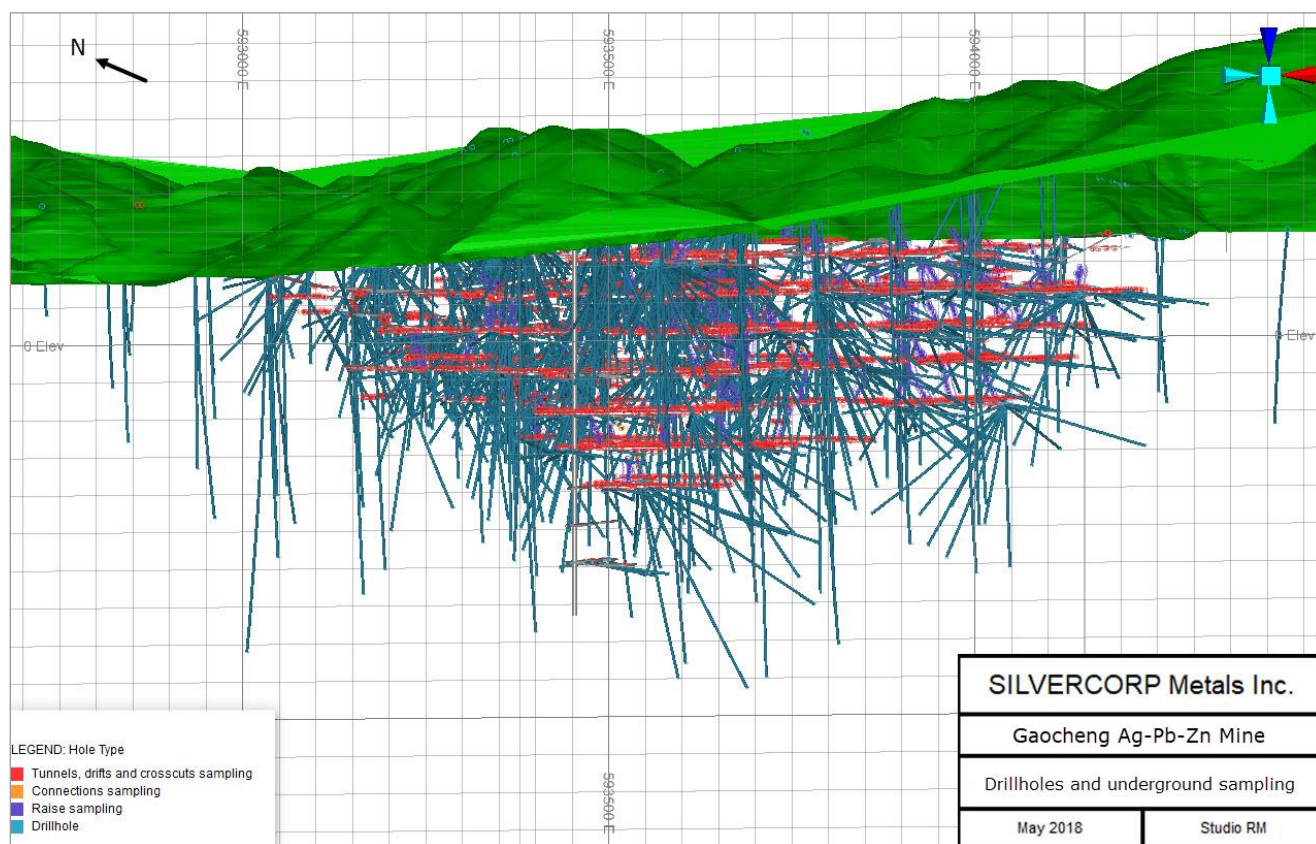

14.2.2 Bulk density

Silvercorp performed 62 density measurements from the core drilled on the Property. The collection of bulk density measurements is described in Section 10.

An average bulk density of 3.57 was assigned to all blocks in the model.

AMC recommends Silvercorp collect additional samples to represent various mineralization types including low grade, medium grade, high grade, and waste material.

14.3 Domain modelling

14.3.1 Lithological and mineralization domains

The GC deposit consists of 89 veins. The lithological domains were constructed for each vein. The vein domains were modelled in Micromine and provided by Silvercorp. The vein domains are based on the vein structure and not on grade. The domains were reviewed and accepted by AMC.

As the lithology domains constrained the extent of the veins, these domains were also used for the mineralization domains.

The blocks inside the block model are coded by estimated silver, lead, and zinc.

Figure 14.2 shows the mineralization domains (red colour) in the plan view.

Visual checks were carried out to ensure that the constraining wireframes respected the raw data.

Figure 14.2 Plan view of mineralization domains

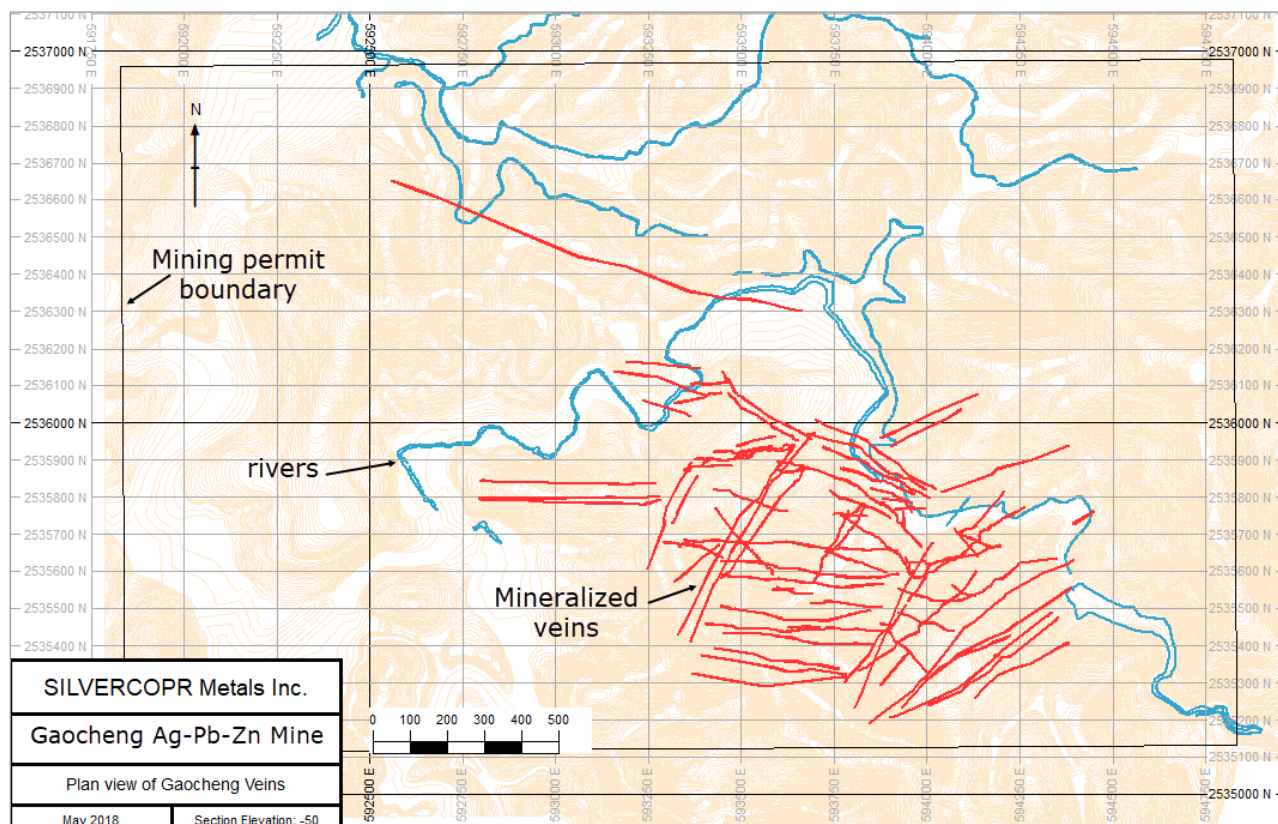

Source: AMC Mining Consultants (Canada) Ltd.

As illustrated in Figure 14.2 above, the GC deposit is comprised of 89 veins including numerous small veins. Figure 14.3 below shows a pie chart of the veins by tonnes of classified material. As it is not feasible to list the details of all 89 veins in all tables, only the capping section, which has quite variable impacts to the grade, tabulates the results for all veins. The other sections discuss only the 10 largest veins based on tonnes. Procedures and parameters of these 10 veins are representative of the whole. Other exceptions are Table 14.5 and Table 14.9 where the Mineral Resource for each vein at 100 g/t Ag Eq is tabulated.

Figure 14.3 Pie chart of 89 veins by classified tonnes

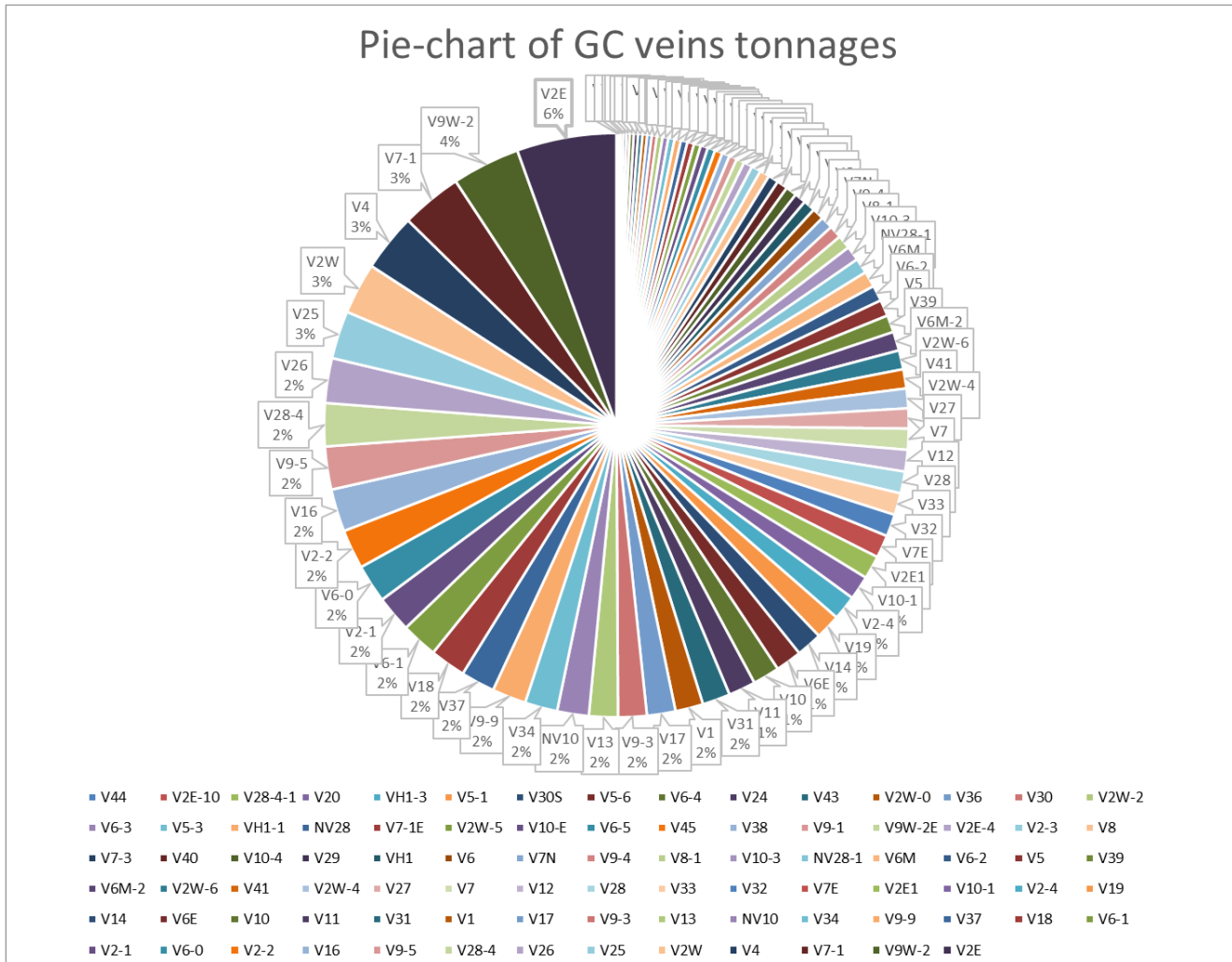

14.4 Statistics, capping, and compositing

Capping was applied prior to compositing. The capping values were determined by 97.5% cumulative distributive assay values for each vein. Capping levels are shown in Table 14.3. As the impact on each vein quite variable, the details for each vein are shown below.

Table 14.3 Grade capping summary

Silver							Lead							Zinc						
Vein number	Vein	Top cut	Original mean	New mean	Number of samples top cut	Difference of mean in %	Vein number	Vein	Top cut	Original mean	New mean	Number of samples top cut	Difference of mean in %	Vein number	Vein	Top cut	Original mean	New mean	Number of samples top cut	Difference of mean in %
1	NV10	363.905	71.6	69.3	5	-3.19	1	NV10	7.335	1.34	1.26	6	-5.51	1	NV10	9.83	2.66	2.62	7	-1.84
2	NV28	661.903	107.8	103.6	4	-3.87	2	NV28	18.053	1.92	1.86	5	-3.16	2	NV28	12.919	3.25	3.18	6	-2.30
3	NV28-1	1141.717	78.6	76.9	3	-2.13	3	NV28-1	15.178	1.39	1.22	4	-12.14	3	NV28-1	11.232	1.94	1.90	4	-2.33
4	V1	302	43.1	41.2	1	-4.61	4	V1	12.027	2.02	1.91	3	-5.26	4	V1	12.385	2.55	2.49	3	-2.37
5	V2-1	550.516	36.9	35.3	1	-4.49	5	V2-1	7.976	0.53	0.53	1	-0.36	5	V2-1	8.677	1.21	1.21	1	-0.05
6	V2-2	370.59	26.5	25.6	1	-3.47	6	V2-2	2.175	0.14	0.14	1	-3.46	6	V2-2	9.452	1.11	1.11	1	-0.18
7	V2-3	423.955	76.2	73.8	3	-3.11	7	V2-3	7.16	1.13	1.06	3	-6.76	7	V2-3	10.254	2.91	2.86	4	-1.80
8	V2-4	451.155	37.8	34.7	1	-8.09	8	V2-4	6.068	0.61	0.60	1	-1.15	8	V2-4	12.5	1.59	1.49	1	-6.81
9	V2E	635.863	108.5	103.9	15	-4.29	9	V2E	10.3	1.64	1.54	18	-6.08	9	V2E	11.341	2.97	2.91	20	-1.81
10	V2E1	604.473	147.1	145.1	9	-1.39	10	V2E1	10.24	1.80	1.74	9	-3.57	10	V2E1	11.411	3.14	3.10	10	-1.32
11	V2E-4	225.745	27.2	27.2	1	-0.26	11	V2E-4	11.796	0.53	0.53	1	-0.19	11	V2E-4	9.567	1.34	1.33	1	-0.55
12	V2E-10	80.863	39.1	39.0	1	-0.07	12	V2E-10	1.779	0.91	0.91	1	-0.24	12	V2E-10	1.813	1.28	1.27	1	-0.75
13	V2W	537.122	131.7	128.2	21	-2.65	13	V2W	11.431	1.57	1.47	17	-6.20	13	V2W	14.147	3.30	3.23	25	-2.09
14	V2W-0	460.157	28.0	27.2	1	-2.97	14	V2W-0	0.902	0.06	0.06	1	-0.47	14	V2W-0	13.006	0.87	0.84	1	-3.41
15	V2W-2	177.271	26.7	26.6	1	-0.29	15	V2W-2	7.27	0.50	0.47	1	-5.65	15	V2W-2	3.131	0.55	0.55	1	-0.13
16	V2W-4	410.403	40.7	40.1	1	-1.37	16	V2W-4	9.097	0.40	0.36	1	-10.31	16	V2W-4	9.383	0.48	0.48	1	-0.96
17	V2W-5	596.426	81.9	80.2	1	-2.07	17	V2W-5	7.447	0.60	0.57	1	-3.56	17	V2W-5	6.175	1.40	1.40	1	-0.53
18	V2W-6	384.56	27.9	26.2	1	-6.21	18	V2W-6	6.54	0.63	0.57	2	-9.08	18	V2W-6	6.001	0.83	0.77	6	-7.52
19	V4	1010.804	105.5	103.9	1	-1.53	19	V4	3.923	0.55	0.53	1	-3.90	19	V4	5.573	0.68	0.67	1	-1.73
20	V5	331.674	38.2	37.9	1	-0.74	20	V5	4.743	0.16	0.16	1	-1.04	20	V5	15.425	1.65	1.63	1	-1.11
21	V5-1	942.038	106.3	103.0	1	-3.11	21	V5-1	9.001	0.52	0.48	1	-7.01	21	V5-1	16.772	4.89	4.81	2	-1.63
22	V5-3	889.609	39.4	36.9	1	-6.55	22	V5-3	6.41	0.14	0.13	1	-5.55	22	V5-3	26.279	2.09	2.05	1	-1.99
23	V5-5	340.24	46.7	46.3	1	-0.80	23	V5-5	4.59	0.31	0.29	1	-6.62	23	V5-5	9.93	1.48	1.46	1	-0.99
24	V5-6	539.9	79.6	74.7	1	-6.18	24	V5-6	5.589	0.57	0.54	1	-4.99	24	V5-6	12.016	2.78	2.75	1	-0.89
25	V6	332.735	69.0	66.4	1	-3.82	25	V6	14.866	1.01	0.99	1	-2.31	25	V6	17.71	3.54	3.53	2	-0.37
26	V6-0	228.763	32.7	32.6	1	-0.24	26	V6-0	14.306	0.86	0.80	1	-7.20	26	V6-0	9.74	1.85	1.83	1	-0.79
27	V6-1	363.085	34.6	34.4	1	-0.46	27	V6-1	4.906	0.41	0.41	1	-0.14	27	V6-1	17.024	1.82	1.74	1	-4.04
28	V6-2	533.141	65.6	62.5	1	-4.65	28	V6-2	5.788	0.75	0.73	1	-2.21	28	V6-2	9.672	1.11	1.05	1	-4.77
29	V6-3	1407.23	191.8	183.9	1	-4.13	29	V6-3	6.409	1.09	1.06	1	-2.59	29	V6-3	14.387	3.75	3.71	1	-1.16
30	V6-4	148.272	51.4	51.3	1	-0.22	30	V6-4	12.522	2.28	2.24	1	-1.92	30	V6-4	11.467	2.93	2.87	1	-2.06
31	V6-5	1996.294	82.7	76.8	1	-7.23	31	V6-5	6.914	0.58	0.56	1	-2.44	31	V6-5	10.265	1.17	1.15	1	-1.57
32	V6E	116.403	14.7	14.6	1	-0.49	32	V6E	2.716	0.23	0.23	1	-0.54	32	V6E	11.38	1.57	1.55	1	-1.20
33	V6M	324.291	49.1	36.9	23	-24.86	33	V6M	19.683	2.73	1.15	60	-57.85	33	V6M	15.247	2.37	2.23	9	-6.04
34	V6M-2	325.59	47.8	47.4	1	-0.67	34	V6M-2	14.886	2.26	2.22	1	-1.56	34	V6M-2	15.231	2.41	2.37	2	-1.78
35	V7	374.397	60.0	58.1	3	-3.10	35	V7	8.381	0.85	0.83	3	-1.95	35	V7	10.356	1.96	1.94	4	-1.00
36	V7-1	567.009	76.2	72.4	6	-5.04	36	V7-1	8.544	0.35	0.32	3	-7.67	36	V7-1	16.85	1.67	1.61	6	-3.89
37	V7-1E	480.93	59.6	57.8	1	-3.13	37	V7-1E	4.576	0.45	0.45	1	-0.27	37	V7-1E	7.233	1.38	1.36	1	-1.24
38	V7-3	1359.884	78.4	63.7	1	-18.72	38	V7-3	4.54	0.05	0.05	1	-0.67	38	V7-3	14.605	1.66	1.66	1	-0.16
39	V7E	556.654	77.0	75.5	3	-1.99	39	V7E	14.423	1.62	1.55	5	-4.23	39	V7E	13.921	3.16	3.05	5	-3.47
40	V7N	58.636	28.0	27.9	1	-0.06	40	V7N	2.424	0.79	0.76	1	-3.64	40	V7N	6.679	2.53	2.51	1	-0.56
41	V8	714.768	122.3	119.3	1	-2.51	41	V8	6.937	0.26	0.26	1	-1.42	41	V8	5.82	0.57	0.57	1	-0.51
42	V8-1	390.312	95.6	95.3	1	-0.30	42	V8-1	6.155	0.61	0.60	1	-1.94	42	V8-1	3.598	0.55	0.54	1	-0.48
43	V9-1	1021.699	97.3	97.3	0	0.00	43	V9-1	11.879	0.75	0.74	1	-0.64	43	V9-1	11.079	2.21	2.19	2	-0.89
44	V9-3	1298.842	98.6	91.3	3	-7.39	44	V9-3	9.291	0.46	0.45	2	-2.12	44	V9-3	13.545	1.78	1.72	4	-2.96
45	V9-4	421.636	28.6	28.3	1	-1.02	45	V9-4	3.102	0.40	0.39	1	-3.50	45	V9-4	19.357	1.28	1.27	1	-1.20

Silver							Lead							Zinc						
Vein number	Vein	Top cut	Original mean	New mean	Number of samples top cut	Difference of mean in %	Vein number	Vein	Top cut	Original mean	New mean	Number of samples top cut	Difference of mean in %	Vein number	Vein	Top cut	Original mean	New mean	Number of samples top cut	Difference of mean in %
46	V9-5	561.771	88.5	85.2	9	-3.72	46	V9-5	12.329	1.31	1.24	9	-5.18	46	V9-5	14.488	2.92	2.86	12	-2.11
47	V9-9	1384.298	82.3	80.6	2	-2.14	47	V9-9	4.088	0.49	0.47	3	-3.33	47	V9-9	11.014	1.23	1.20	3	-1.92
48	V9W-2	692.824	80.1	72.7	7	-9.23	48	V9W-2	6.421	0.49	0.47	6	-3.00	48	V9W-2	13.159	1.72	1.68	8	-2.23
49	V9W-2E	708.722	90.9	88.5	1	-2.65	49	V9W-2E	13.022	1.60	1.44	1	-10.35	49	V9W-2E	18.528	2.63	2.36	1	-10.36
50	V10	307.359	61.7	60.2	3	-2.45	50	V10	9.965	1.77	1.75	5	-1.30	50	V10	8.714	3.12	3.08	6	-1.29
51	V10-1	700.154	97.3	92.8	5	-4.57	51	V10-1	9.048	0.90	0.87	4	-2.89	51	V10-1	24.03	5.22	5.17	7	-0.96
52	V10-3	287.304	25.5	25.2	1	-1.39	52	V10-3	7.095	0.45	0.45	1	-0.58	52	V10-3	6.18	1.02	1.00	1	-2.02
53	V10-4	484.86	93.7	92.5	1	-1.35	53	V10-4	11.96	1.26	1.23	1	-2.49	53	V10-4	10.189	2.06	2.04	1	-0.67
54	V10E	573	37.9	37.9	0	0.00	54	V10E	1.28	0.34	0.29	2	-15.59	54	V10E	2.54	0.55	0.54	1	-2.03
55	V11	366.833	49.0	45.7	1	-6.76	55	V11	10.998	1.47	1.32	2	-10.45	55	V11	8.209	2.21	2.19	2	-0.64
56	V12	443.705	62.1	58.1	2	-6.42	56	V12	5.219	0.28	0.26	1	-6.98	56	V12	19.632	3.09	3.01	3	-2.66
57	V13	460.091	46.9	45.1	1	-3.77	57	V13	8.801	0.67	0.61	1	-7.67	57	V13	17.298	1.63	1.61	1	-0.71
58	V14	745.588	113.8	106.0	3	-6.85	58	V14	16.952	1.47	1.45	3	-1.36	58	V14	25.316	3.48	3.40	4	-2.33
59	V16	817.808	103.0	97.4	7	-5.49	59	V16	6.443	0.80	0.77	7	-2.83	59	V16	13.247	1.94	1.92	9	-1.38
60	V17	985.725	93.8	76.0	2	-18.97	60	V17	2.342	0.41	0.40	2	-0.68	60	V17	10.114	0.57	0.55	2	-3.33
61	V18	907.43	57.8	57.5	1	-0.48	61	V18	5.436	0.47	0.46	1	-0.96	61	V18	4.21	0.33	0.32	1	-2.87
62	V19	477.742	76.1	70.1	3	-7.79	62	V19	9.092	1.13	1.06	4	-6.23	62	V19	16.138	3.56	3.36	5	-5.72
63	V20	358.791	86.4	85.8	1	-0.63	63	V20	14.736	3.13	3.08	1	-1.54	63	V20	7.708	3.86	3.83	2	-0.83
64	V24	1320.341	218.7	210.0	2	-3.99	64	V24	18.228	1.57	1.53	2	-2.35	64	V24	21.391	4.57	4.52	2	-1.18
65	V25	614.29	37.7	37.0	1	-1.98	65	V25	6.776	0.38	0.37	1	-1.47	65	V25	8.619	0.86	0.86	1	-0.86
66	V26	634.999	44.6	42.4	2	-4.90	66	V26	18.184	0.79	0.76	2	-3.73	66	V26	9.599	1.10	1.05	4	-4.97
67	V27	270.736	39.0	38.9	1	-0.33	67	V27	3.271	0.39	0.38	1	-1.51	67	V27	3.95	0.50	0.50	1	-0.56
68	V28	898.097	89.7	84.2	4	-6.09	68	V28	20.435	1.53	1.37	3	-10.45	68	V28	12.771	2.06	2.04	6	-1.10
69	V28-4	614.565	96.6	94.5	7	-2.18	69	V28-4	12.737	1.25	1.10	6	-12.29	69	V28-4	16.365	3.09	3.02	8	-2.05
70	V28-4-1	308.42	90.5	89.8	1	-0.84	70	V28-4-1	1.135	0.20	0.20	1	-0.20	70	V28-4-1	15.177	4.17	4.06	2	-2.51
71	V29	587.469	53.7	53.2	1	-0.93	71	V29	2.684	0.22	0.21	1	-0.95	71	V29	29.818	4.33	4.33	1	-0.09
72	V30	206.626	16.3	16.1	1	-1.38	72	V30	14.085	0.73	0.69	1	-5.28	72	V30	7.387	0.79	0.78	1	-1.12
73	V30S	194	54.8	54.8	0	0.00	73	V30S		0.16	0.16	0	0.00	73	V30S	0.84	1.09	0.38	1	-65.35
74	V31	374.34	28.0	27.4	1	-2.20	74	V31	2.449	0.31	0.31	1	-0.18	74	V31	7.677	0.55	0.54	1	-2.16
75	V32	296.264	50.9	50.1	1	-1.44	75	V32	7.354	1.22	1.21	1	-0.66	75	V32	8.794	1.67	1.66	1	-0.90
76	V33	576.89	78.1	75.4	1	-3.41	76	V33	4.481	1.09	1.04	1	-3.84	76	V33	3.953	1.35	1.35	1	-0.26
77	V34	152	29.0	29.0	0	0.00	77	V34	0.569	0.18	0.18	1	-0.08	77	V34	2.097	0.72	0.71	1	-0.45
78	V36	466.717	78.0	76.9	2	-1.44	78	V36	11.42	1.50	1.48	2	-1.25	78	V36	11.081	3.08	2.94	3	-4.71
79	V37	262.81	70.1	69.5	1	-0.86	79	V37	5.585	0.88	0.86	1	-2.47	79	V37	5.909	1.37	1.33	1	-2.48
80	V38	171	16.3	16.3	0	0.00	80	V38	1.48	0.13	0.13	0	0.00	80	V38	1.97	0.17	0.17	0	0.00
81	V39	173.545	40.8	40.8	1	-0.04	81	V39	2.584	0.23	0.22	1	-0.63	81	V39	8.613	0.61	0.61	1	-0.95
82	V40	680.923	161.7	158.1	1	-2.23	82	V40	6.019	0.60	0.56	1	-6.70	82	V40	7.214	1.16	1.11	1	-3.90
83	V41	202.905	17.8	17.8	1	-0.45	83	V41	5.175	0.37	0.35	1	-6.68	83	V41	21.056	0.95	0.85	1	-10.57
84	V43	492.988	123.6	123.0	1	-0.51	84	V43	17.51	1.00	1.00	0	0.00	84	V43	16.683	3.09	3.01	1	-2.47
85	V44	398.68	87.4	83.9	1	-4.07	85	V44	9.658	1.69	1.57	1	-7.21	85	V44	6.003	1.84	1.83	1	-0.52
86	V45	762.525	132.3	131.8	1	-0.40	86	V45	2.776	0.31	0.31	1	-0.68	86	V45	4.453	0.68	0.67	1	-0.39
87	VH1	89.156	23.6	23.4	1	-0.82	87	VH1	6.797	1.87	1.86	1	-0.56	87	VH1	5.721	1.70	1.70	1	-0.11
88	VH1-1	192.725	37.8	37.6	1	-0.45	88	VH1-1	16.479	2.43	2.27	1	-6.44	88	VH1-1	15.05	2.01	1.94	1	-3.36
89	VH1-3	243.719	39.4	38.7	1	-1.87	89	VH1-3	19.217	2.57	2.50	1	-2.71	89	VH1-3	16.562	2.85	2.80	1	-1.68

Source: Silvercorp, reproduced as a check by AMC Mining Consultants (Canada) Ltd.

The provided assay file contains 49,020 samples. Prior to sample selection in the wireframe, Silvercorp inserted intervals with zero grades where no samples were taken. The total numbers of samples within the mineralization wireframes is 12,252 including 1,213 inserted zeroes. This is approximately 10% of the data. The average sampling interval of assays is about 1 m, the minimum sample length is 0.4 m and maximum 15.28 m.

The compositing length is equal to the vein width. The average composite length increased to 1.3 m and maximum is 22.45 m. The total number of samples decreased to 9,787.

The raw, composited, and capped assay data for the 10 largest mineralized veins are shown in Table 14.4. In the statistics table the grades were weighted by samples length.

Table 14.4 Statistics of raw, capped, and composited assay data for the selected 10 veins

Vein	Field	Ag (g/t)			Pb (%)			Zn (%)		
		Raw	Capped	Composite	Raw	Capped	Composite	Raw	Capped	Composite
NV10	No samples	350	350	247	350	350	247	350	350	247
	Minimum	0	0	0	0	0	0	0	0	0
	Maximum	1,119	364	364	21.92	7.34	7	21.06	9.83	10
	Mean	71	69	69	1.33	1.26	1.26	2.66	2.61	2.62
	Standard Dev.	96.30	81.20	73.43	2.03	1.60	1.41	2.55	2.35	2.06
	Coeff. Var	1.35	1.17	1.06	1.52	1.27	1.12	0.96	0.90	0.79
V1	No samples	161	161	118	161	161	118	161	161	118
	Minimum	0	0	0	0	0	0	0	0	0
	Maximum	573	302	302	28.49	12.03	10	15.26	12.39	12
	Mean	43	41	41	2.04	1.93	1.93	2.57	2.51	2.51
	Standard Dev.	68.23	55.37	48.42	3.26	2.68	2.24	3.00	2.77	2.36
	Coeff. Var	1.57	1.34	1.17	1.60	1.39	1.16	1.17	1.10	0.94
V2E	No samples	997	997	614	997	997	614	997	997	614
	Minimum	0	0	0	0	0	0	0	0	0
	Maximum	2,015	636	636	53.27	10.30	10	19.34	11.34	11
	Mean	109	104	104	1.64	1.54	1.54	2.98	2.92	2.92
	Standard Dev.	151.06	120.06	97.18	2.84	2.10	1.68	2.88	2.67	2.13
	Coeff. Var	1.39	1.16	0.94	1.73	1.36	1.09	0.97	0.91	0.73
V2E1	No samples	457	457	223	457	457	223	457	457	223
	Minimum	0	0	0	0	0	0	0	0	0
	Maximum	1,063	604	594	25.81	10.24	10	17.46	11.41	11
	Mean	146	144	144	1.80	1.73	1.73	3.11	3.06	3.06
	Standard Dev.	142.67	133.59	104.26	2.55	2.16	1.51	2.90	2.75	2.09
	Coeff. Var	0.98	0.93	0.73	1.42	1.25	0.87	0.93	0.90	0.68
V2W	No samples	1229	1229	530	1229	1229	530	1229	1229	530
	Minimum	0	0	0	0	0	0	0	0	0
	Maximum	1,533	537	537	32.27	11.43	11	30.00	14.15	14
	Mean	131	128	128	1.58	1.47	1.47	3.33	3.26	3.26
	Standard Dev.	136.57	119.90	81.04	2.93	2.28	1.72	3.41	3.11	2.27
	Coeff. Var	1.04	0.94	0.64	1.85	1.55	1.17	1.03	0.95	0.70

Vein	Field	Ag (g/t)			Pb (%)			Zn (%)		
		Raw	Capped	Composite	Raw	Capped	Composite	Raw	Capped	Composite
V7E	No samples	245	245	126	245	245	126	245	245	126
	Minimum	0	0	0	0	0	0	0	0	0
	Maximum	846	557	557	24.18	14.42	14	31.18	13.92	14
	Mean	79	77	77	1.66	1.59	1.59	3.23	3.11	3.11
	Standard Dev.	110.50	101.69	81.74	2.89	2.46	1.97	3.67	3.10	2.36
	Coeff. Var	1.41	1.32	1.06	1.74	1.55	1.24	1.14	1.00	0.76
V9-5	No samples	643	643	490	643	643	490	643	643	490
	Minimum	0	0	0	0	0	0	0	0	0
	Maximum	1,104	562	562	26.19	12.33	12	28.17	14.49	14
	Mean	89	85	85	1.31	1.24	1.24	2.92	2.86	2.86
	Standard Dev.	130.23	112.15	101.23	2.66	2.21	1.92	3.42	3.12	2.82
	Coeff. Var	1.47	1.31	1.18	2.03	1.78	1.54	1.17	1.09	0.98
V9W-2	No samples	592	592	508	592	592	508	592	592	508
	Minimum	0	0	0	0	0	0	0	0	0
	Maximum	5,428	693	693	19.30	6.42	6	25.12	13.16	13
	Mean	80	72	72	0.48	0.47	0.47	1.69	1.65	1.65
	Standard Dev.	219.97	120.96	117.29	1.14	1.01	0.97	2.67	2.45	2.32
	Coeff. Var	2.76	1.68	1.62	2.35	2.15	2.06	1.58	1.49	1.41
V16	No samples	519	519	429	519	519	429	519	519	429
	Minimum	0	0	0	0	0	0	0	0	0
	Maximum	1,742	818	818	11.10	6.44	6	21.87	13.25	13
	Mean	104	98	98	0.79	0.77	0.77	1.94	1.91	1.91
	Standard Dev.	181.60	145.28	135.82	1.27	1.13	1.04	2.58	2.42	2.19
	Coeff. Var	1.75	1.48	1.38	1.60	1.47	1.35	1.33	1.27	1.15
V25	No samples	150	150	137	150	150	137	150	150	137
	Minimum	0	0	0	0	0	0	0	0	0
	Maximum	869	614	614	8.12	6.78	7	11.14	8.62	9
	Mean	37	36	36	0.33	0.32	0.32	0.80	0.79	0.79
	Standard Dev.	93.40	87.32	85.89	0.88	0.83	0.82	1.76	1.72	1.57
	Coeff. Var	2.54	2.43	2.38	2.69	2.59	2.56	2.19	2.16	1.98

Source: Silvercorp, reproduced as a check by AMC Mining Consultants (Canada) Ltd.

14.5 Block model

14.5.1 Block model parameters

The parent block size for all veins was 1 m by 2 m by 2 m (x, y, z) with block percentages employed. AMC imported all 89 block models and based on provided wireframes created sub-celled models for better representation of the mined out volumes. The volume comparison of sub-blocked models versus percentage models showed a difference less than 1%. The sub-celling resulted in minimum cell dimensions of 0.2 m by 0.2 m by 0.4 m (x, y, z).

Each vein is a separate block model with the block model origins, dimensions and rotations used for the estimates being different for each vein. In general block models were rotated around the Z axis by between 23 to 174 degrees in a clockwise direction as shown in Table 14.5. The original block models were provided in UTM grid.

Table 14.5 Block models rotation angles

Vein	Rotation angle	Vein	Rotation angle	Vein	Rotation angle
NV10	45.573694	V20	140	V5-1	94.2
NV28	87.88	V24	47.3949	V5-3	76.48
NV28-1	83.8	V25	31.95	V5-5	84.5
VH1	66	V26	37.57	V5-6	94.006285
VH1-1	63.58	V27	39.222163	V6	74.580744
VH1-3	80.9	V28	40.2	V6E	119.1
V1	146.1	V28-4	39	V6M	132.2
V10	42.3	V28-4-1	44.9	V6M-2	130.3
V10E	29.52346	V29	23.8	V6-0	118.5
V10-1	38.2	V2-1	116.8	V6-1	115.5
V10-3	24.9	V2-2	112.7	V6-2	84.800651
V10-4	41.48	V2-3	118.62	V6-3	113
V11	83.3	V2-4	118.770297	V6-4	95.312932
V12	53	V30	121.91	V6-5	105.83103
V13	41.76	V30S	86.929165	V7	127.9
V14	49.7	V31	50.958	V7E	122.9
V16	89.7	V32	50.95	V7N	57.542677
V17	87.6	V33	50.95	V7-1	94.8
V18	97.3	V34	29.617	V7-1E	109.6
V19	95.4	V36	32.9	V7-3	103.2
V2E	119.1	V37	69.747202	V8	89.8
V2E1	86	V38	90.865595	V8-1	95.494869
V2E-10	173.752469	V39	88.926609	V9W-2	94.3
V2E-4	106.88995	V4	99.52	V9W-2E	107.2
V2W	79	V40	89.209022	V9-1	103.54
V2W-0	87.3	V41	90.845012	V9-3	98.1
V2W-2	98.42	V43	134.83	V9-4	92.788012
V2W-4	81.3	V44	111.187582	V9-5	98
V2W-5	104.8	V45	49.734927	V9-9	43.7
V2W-6	82	V5	92.3		

Source: Silvercorp Metals Inc.

14.5.2 Grade estimation

Interpolation was carried out using the inverse distanced cubed (ID³) method. Four passes were employed.

The search distances are shown in Table 14.6 along with the minimum and maximum number of composite samples used for each pass.

Table 14.6 Micromine search parameters

Pass	Search distance	Search sector	Max sample / sector	Min sample / block	Min work / block	Work counted
1	30	4	2	2	2	Adit + Raise
2	60	4	2	2	1	All
3	120	4	2	1	1	All
4	180	4	1	1	1	All

Source: Silvercorp Metals Inc.

Note: The estimation by sectors means use of quadrant method.

14.5.3 Mining depletion

Mining depletion and write offs were coded into the block models by Silvercorp, which were based on survey information to 31 December 2017. An example of depletion coding is displayed for the V2E vein in Figure 14.4.

Figure 14.4 Mining depletion longitudinal project vein V2E

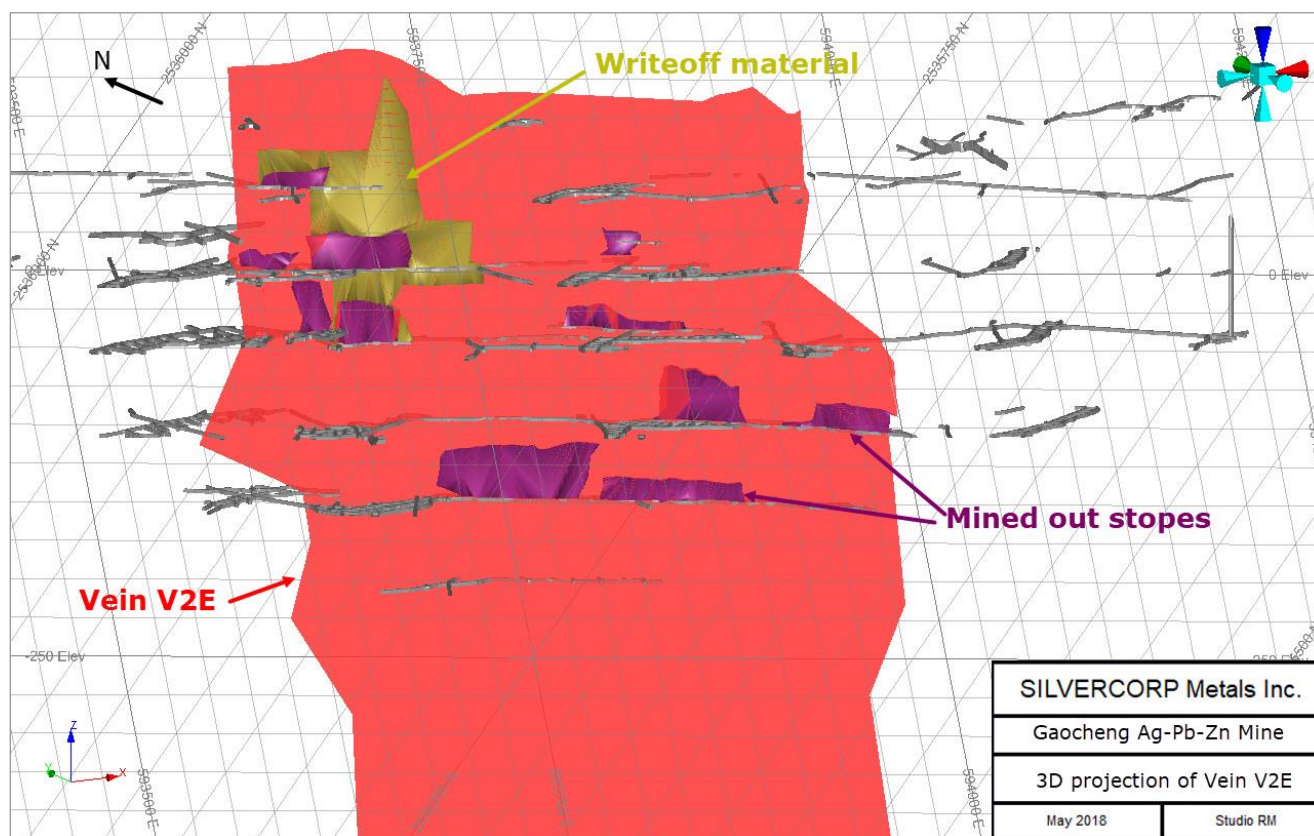

The total tonnage of mined out stopes at 0 cut-off grade is about 985,000 tonnes of classified blocks. The tonnage of the underground developments that was assigned in the block models is approximately 200,000 tonnes. The blocks of veins that are assigned by written off code (sterilization) based on wireframes contain about 620,000 tonnes.

Figure 14.5 Plan view of mined out stope (purple) and written-off shapes (yellow)

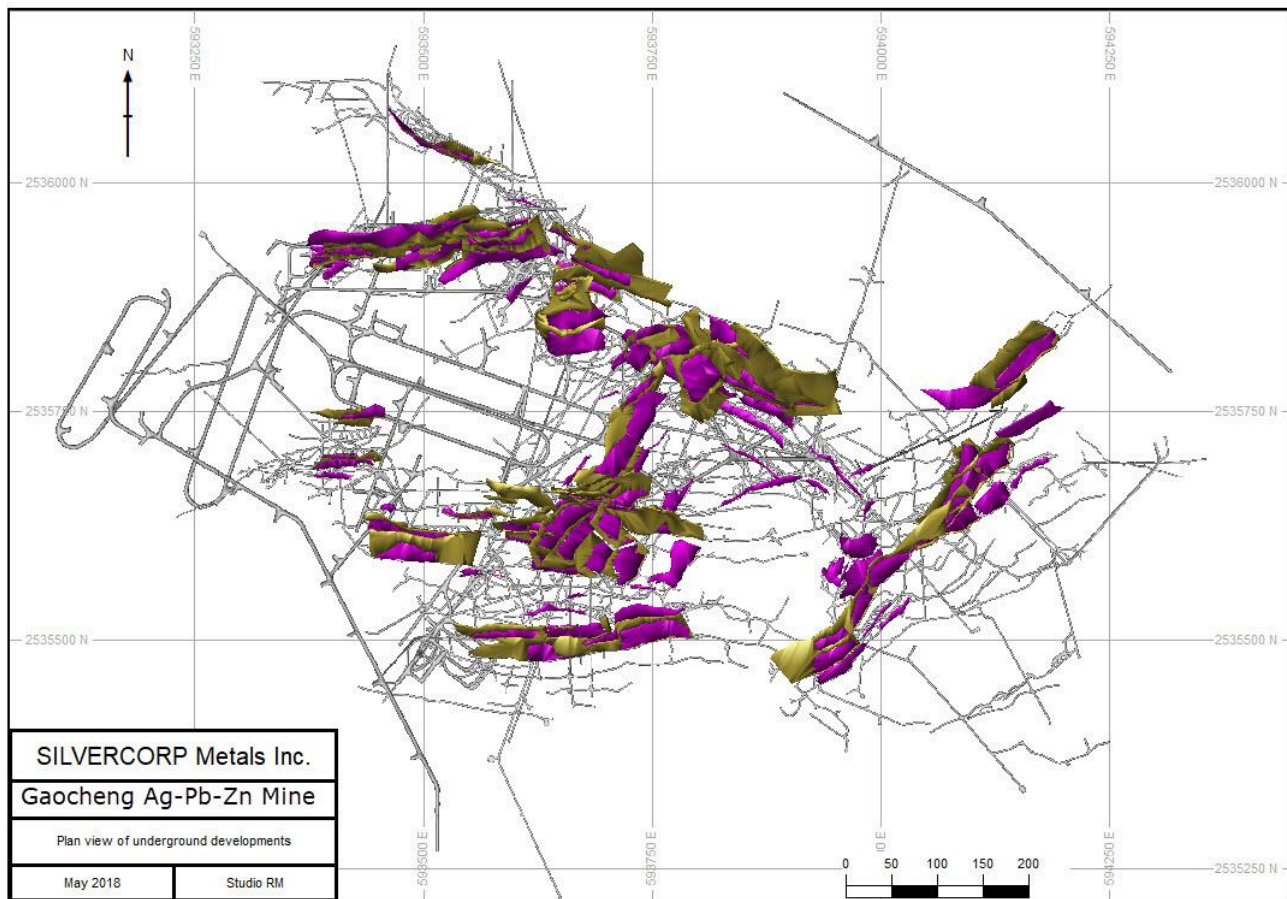

14.5.4 Resource classification

Mineral Resource classification, as originally provided by Silvercorp, only classified material above a certain silver equivalent cut-off value. As equivalency formulas are dependent on metal prices that change over time, this classification did not reflect current mining practices. A review of as-built and classification showed areas of mining in parts of the vein that were unclassified. To resolve this issue, AMC recommended a change to the classification system using an assessment of mineralization continuity, data quality and data density with data density being the main criteria.

Mineral Resources were classified as Measured, Indicated, and Inferred.

Classification was carried out based on four search passes, with a manual review creating volumes based on sample density and the presence or absence of an exploration drive. This removed outliers and allowed Measured to be restricted to tunnels, but overall gave a better sense of continuity where applicable.

For a block to be classified as Measured, it was necessary to have a minimum of four composites from a minimum of two drillholes or channels located within 25 – 30 m of the block centroid. This was calibrated by the distance from an exploration tunnel.

If blocks were estimated by pass 1 but did not meet the Measured Resource criteria, they were classified as Indicated Resources. Blocks estimated by pass 2 (a minimum of two composites from

a minimum of two drillholes or channels and located within 50 – 60 m of the block centroid) were also classified as Indicated. The horizontal extent of Indicated resources was also locally restricted if adjacent to an exploration drive that ended due to the absence of mineralization.

For a block to be classified as Inferred, it was necessary that a minimum of one composite from minimum of one drillhole was located within maximum 180 m of the block centroid.

Some smaller veins were also classified as an Inferred Resource based on a lack of geological confidence despite sample support for a higher level of resource classification.

Figure 14.6 shows the block model classification for a selected vein.

Figure 14.6 Mineral Resource classification vertical section: vein NV10

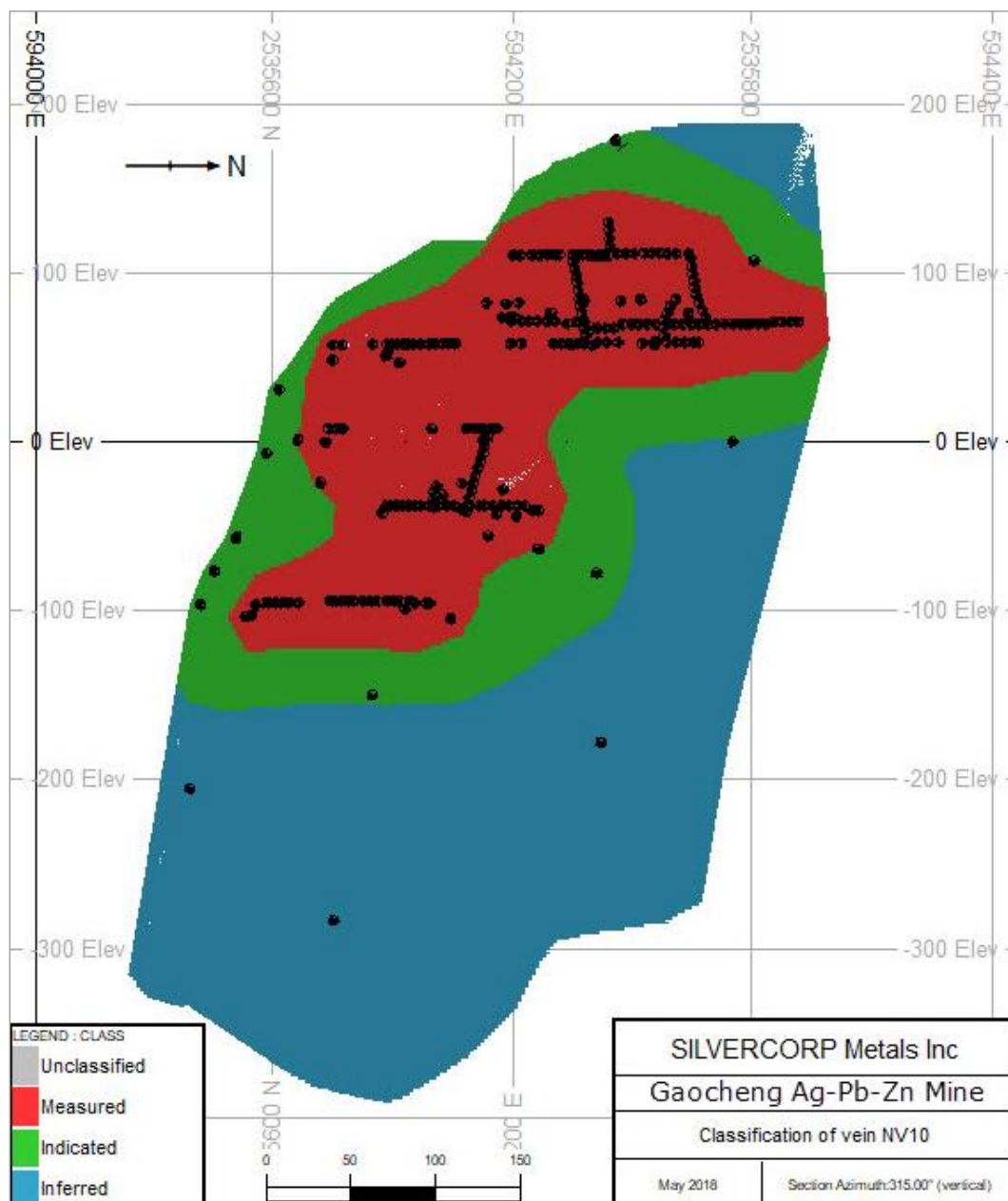

Source: Silvercorp, reproduced as a check by AMC Mining Consultants (Canada) Ltd.

14.5.5 Block model validation

The block models were validated by AMC in four ways. First, visual checks were carried out to ensure that the grades respected the raw assay data. Secondly, swath plots were reviewed. Thirdly, the estimate was statistically compared to the composited assay data, with satisfactory results. Lastly eight block models were re-estimated using independent parameters and ordinary kriging. The results of the OK estimate compared favourably with the ID³ estimates.

Figure 14.7 shows an example of the composite silver grades compared to the block model estimated grades for vein NV10. NV10 contains one of the largest Measured Resource tonnage and silver is the most significant economic metal. The figure shows good agreement between the composite grades and the estimated block model grades.

Figure 14.7 Silver equivalent grades vertical section: vein NV10

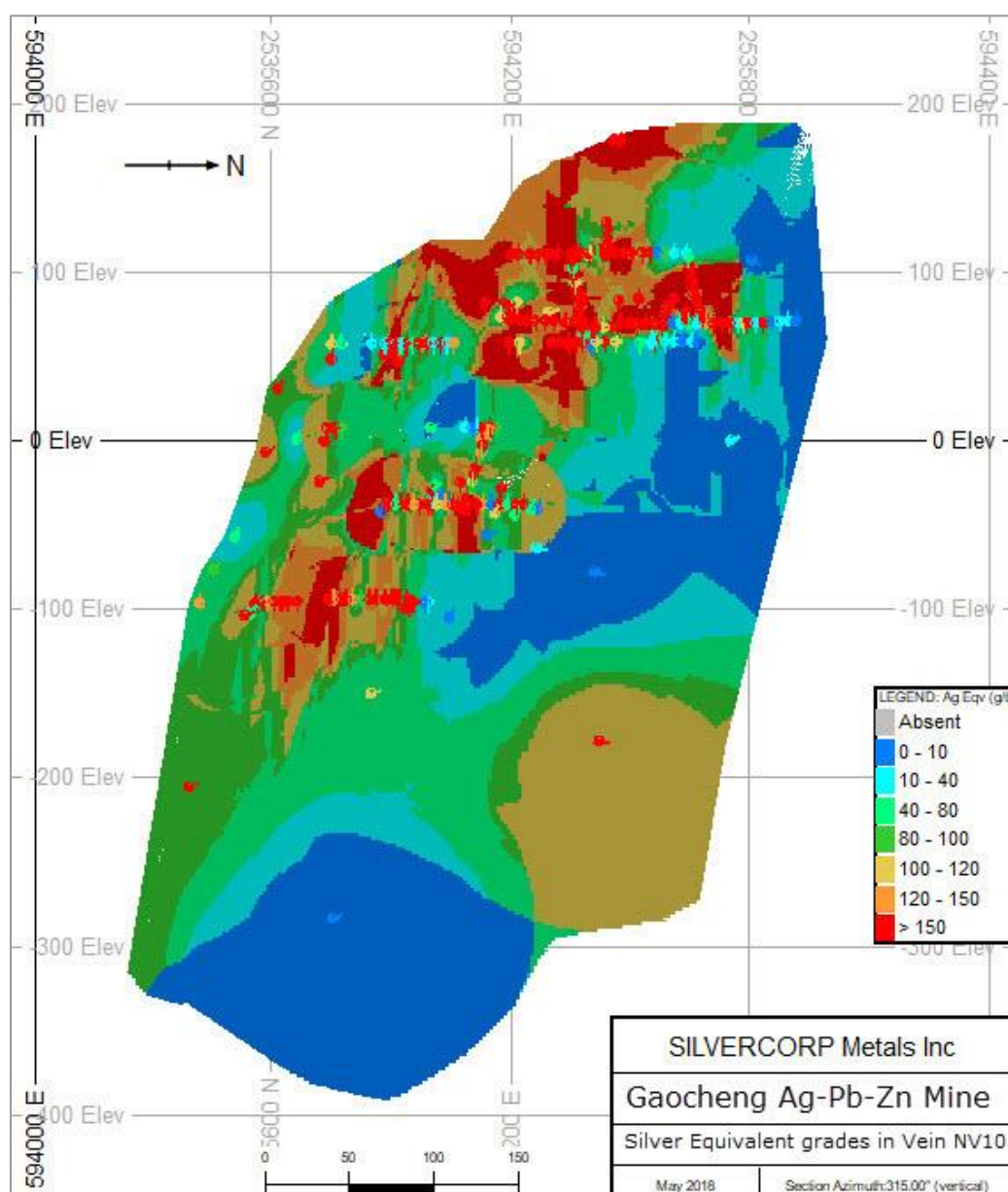

Source: Silvercorp reproduced as a check by AMC Mining Consultants (Canada) Ltd.

Table 14.7 shows the statistical comparison of the composites versus the block model grades for silver, lead, and zinc for the 10 largest veins.

Table 14.7 Statistical comparison of composites and block model for the 10 largest veins

Vein	Data file	Ag (g/t)		Pb (%)		Zn (%)	
		Model	Composite	Model	Composite	Model	Composite
NV10	No records	8,002,197	247	8,002,197	245	8,002,197	247
	Minimum	0	0	0	0	0	0
	Maximum	354.75	364	7.24	7.34	9.5	9.83
	Mean	39	69	0.71	1.26	2	2.62
	Standard Dev.	55.08	73.43	0.73	1.41	1.72	2.06
	Coeff. Var	1.4	1.06	1.03	1.12	0.86	0.79
V1	No records	4,678,867	118	4,678,867	119	4,678,867	118
	Minimum	0	0	0	0	0	0
	Maximum	294.87	302	9.33	9.97	12.18	12.38
	Mean	58	41	1.81	1.93	2.37	2.51
	Standard Dev.	50.08	48.42	1.81	2.25	1.78	2.36
	Coeff. Var	0.87	1.17	1	1.16	0.75	0.94
V2E	No records	17,987,521	614	17,987,521	613	17,987,521	614
	Minimum	0	0	0	0	0	0
	Maximum	636	636	10.27	10.3	11.28	11.34
	Mean	99	104	1.28	1.54	2.67	2.92
	Standard Dev.	79.14	97.18	1.06	1.68	1.56	2.13
	Coeff. Var	0.8	0.94	0.83	1.09	0.58	0.73
V2E1	No records	3,133,627	223	3,133,627	224	3,133,627	223
	Minimum	0	0	0	0	0	0
	Maximum	593.6	594	9.67	10.24	11.38	11.41
	Mean	95	144	1.22	1.73	2.69	3.06
	Standard Dev.	82.3	104.26	1.18	1.5	1.76	2.09
	Coeff. Var	0.87	0.73	0.97	0.87	0.65	0.68
V2W	No records	12,652,326	530	12,652,326	508	12,652,326	530
	Minimum	0	0	0	0	0	0
	Maximum	536.48	537	10.87	11.43	14.15	14.15
	Mean	103	128	1.40	1.47	3.08	3.26
	Standard Dev.	72.93	81.04	1.38	1.7	1.86	2.27
	Coeff. Var	0.71	0.64	0.99	1.16	0.6	0.70
V7E	No records	2,019,079	126	2,019,079	126	2,019,079	126
	Minimum	0	0	0	0	0	0
	Maximum	547.61	557	14.18	14.42	13.7	13.92
	Mean	71	77	1.24	1.59	2.71	3.11
	Standard Dev.	74.14	81.74	1.13	1.96	1.64	2.36
	Coeff. Var	1.05	1.06	0.91	1.23	0.61	0.76

Vein	Data file	Ag (g/t)		Pb (%)		Zn (%)	
		Model	Composite	Model	Composite	Model	Composite
V9-5	No records	10,457,842	490	10,457,842	484	10,457,842	490
	Minimum	0	0	0	0	0	0
	Maximum	556.26	562	12.31	12.33	14.38	14.49
	Mean	66	85	1.02	1.24	2.22	2.86
	Standard Dev.	63.92	101.23	1.27	1.91	1.94	2.82
	Coeff. Var	0.97	1.18	1.24	1.53	0.87	0.98
V9W-2	No records	19,296,417	508	19,296,417	507	19,296,417	508
	Minimum	0	0	0	0	0	0
	Maximum	693	693	6.42	6.42	13.16	13.16
	Mean	45	72	0.36	0.47	1.28	1.65
	Standard Dev.	71.45	117.29	0.61	0.97	1.74	2.32
	Coeff. Var	1.58	1.62	1.72	2.06	1.35	1.41
V16	No records	10,347,257	429	10,347,257	426	10,347,257	429
	Minimum	0	0	0	0	0	0
	Maximum	817.95	818	6.44	6.44	13.2	13.25
	Mean	92	98	0.64	0.77	1.71	1.91
	Standard Dev.	102.57	135.82	0.65	1.04	1.9	2.19
	Coeff. Var	1.11	1.38	1.02	1.35	1.12	1.15
V25	No records	2,750,552	137	2,750,552	137	2,750,552	137
	Minimum	0	0	0	0	0	0
	Maximum	613.95	614	6.71	6.78	8.62	8.62
	Mean	28	36	0.32	0.32	0.79	0.79
	Standard Dev.	53	85.89	0.74	0.82	1.64	1.57
	Coeff. Var	1.89	2.38	2.31	2.56	2.07	1.98

Note: For minimum, maximum and mean values, silver values are in g/t and lead and zinc are in %.
 Source: Silvercorp, reproduced as a check by AMC Mining Consultants (Canada) Ltd.

Figure 14.8, Figure 14.9, and Figure 14.10 show the swath plots for Measured and Indicated blocks for silver, lead and zinc for vein NV10 respectively. The swath plots show good agreement between composites and block model grades.

Figure 14.8 Swath-plot of silver grades in Measured and Indicated blocks of vein NV10

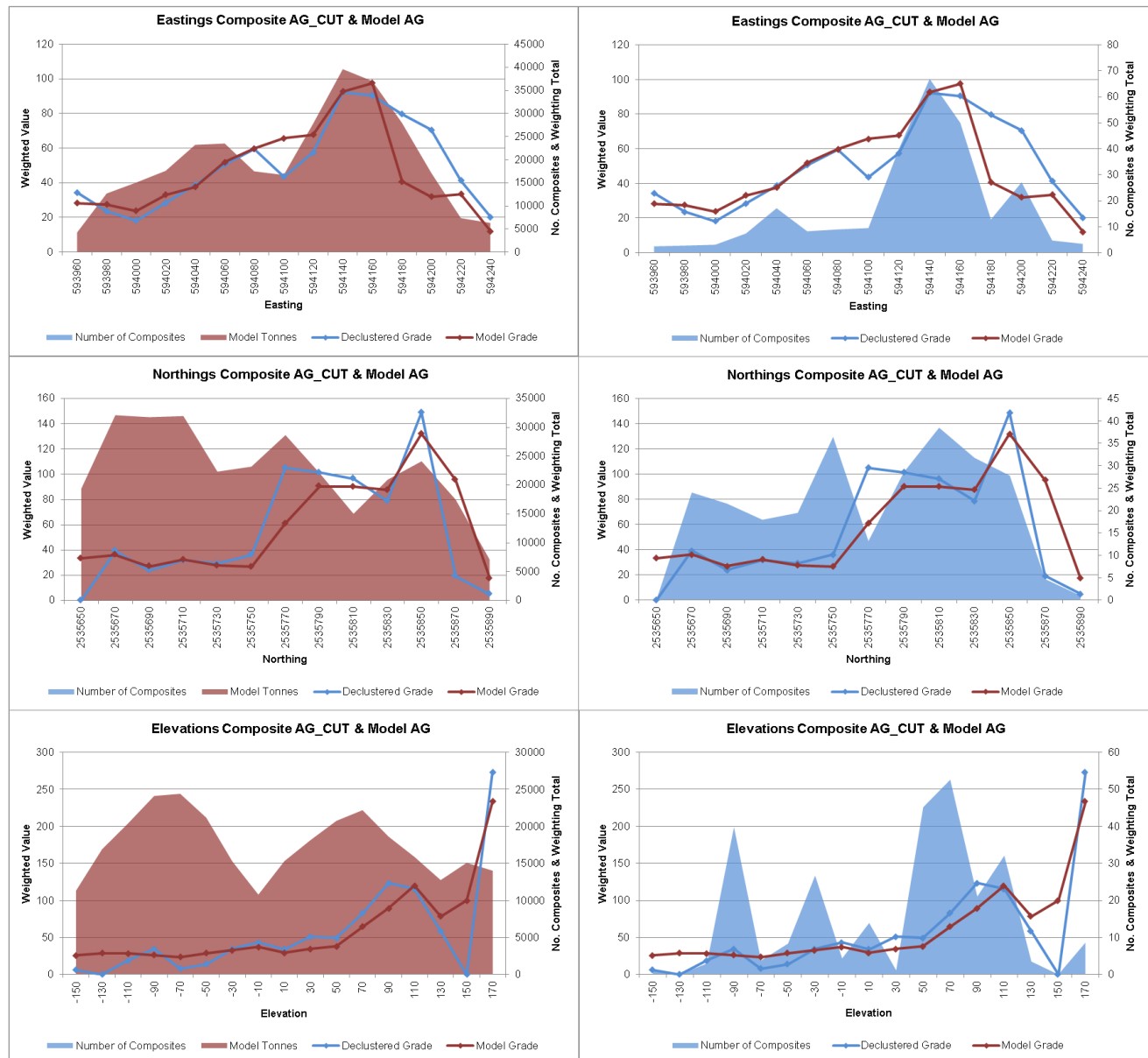

Source: AMC Mining Consultants (Canada) Ltd.

Figure 14.9 Swath-plot of lead grades in Measured and Indicated blocks of vein NV10

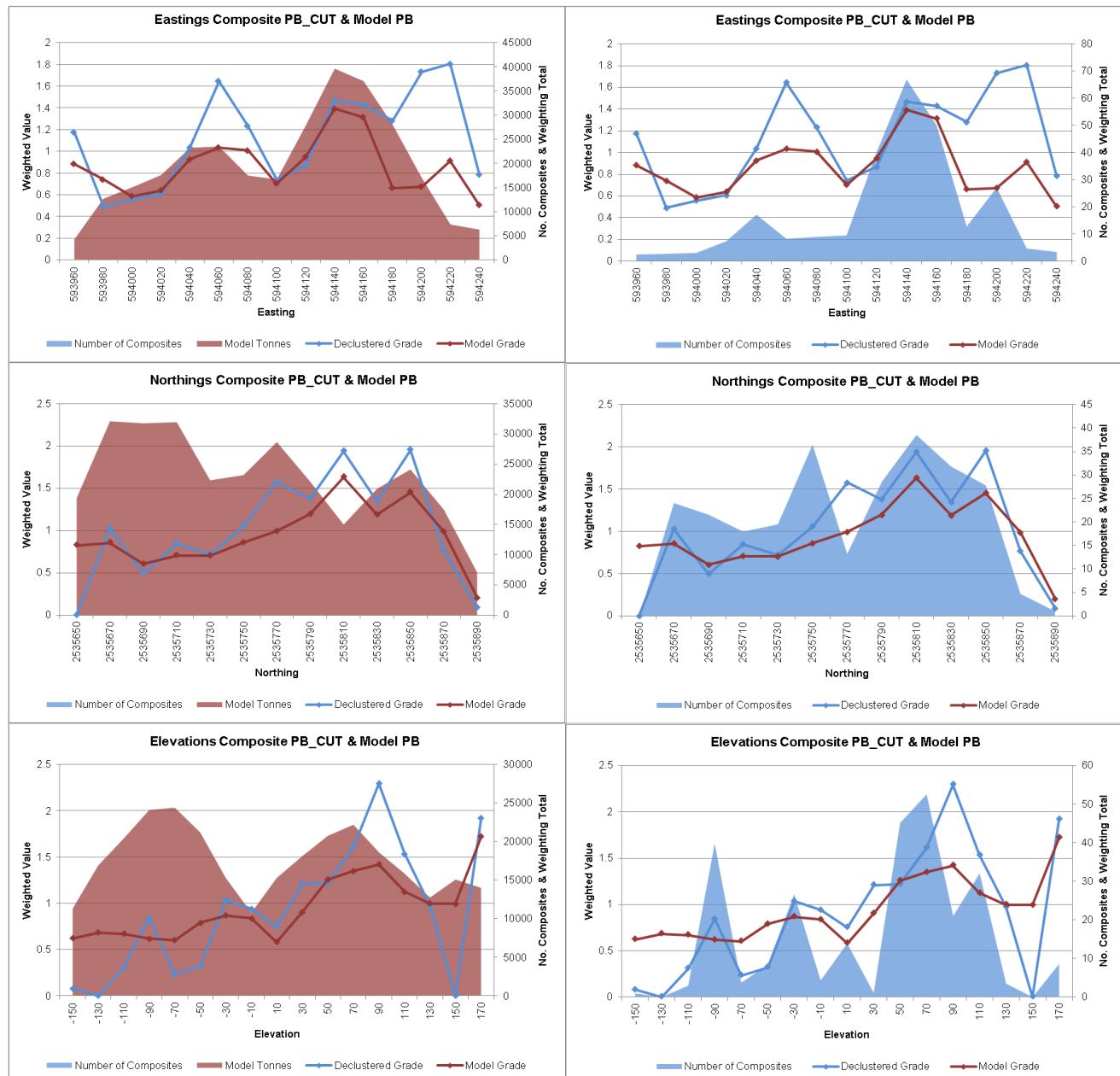

Source: AMC Mining Consultants (Canada) Ltd.

Figure 14.10 Swath-plot of zinc grades in Measured and Indicated blocks of vein NV10

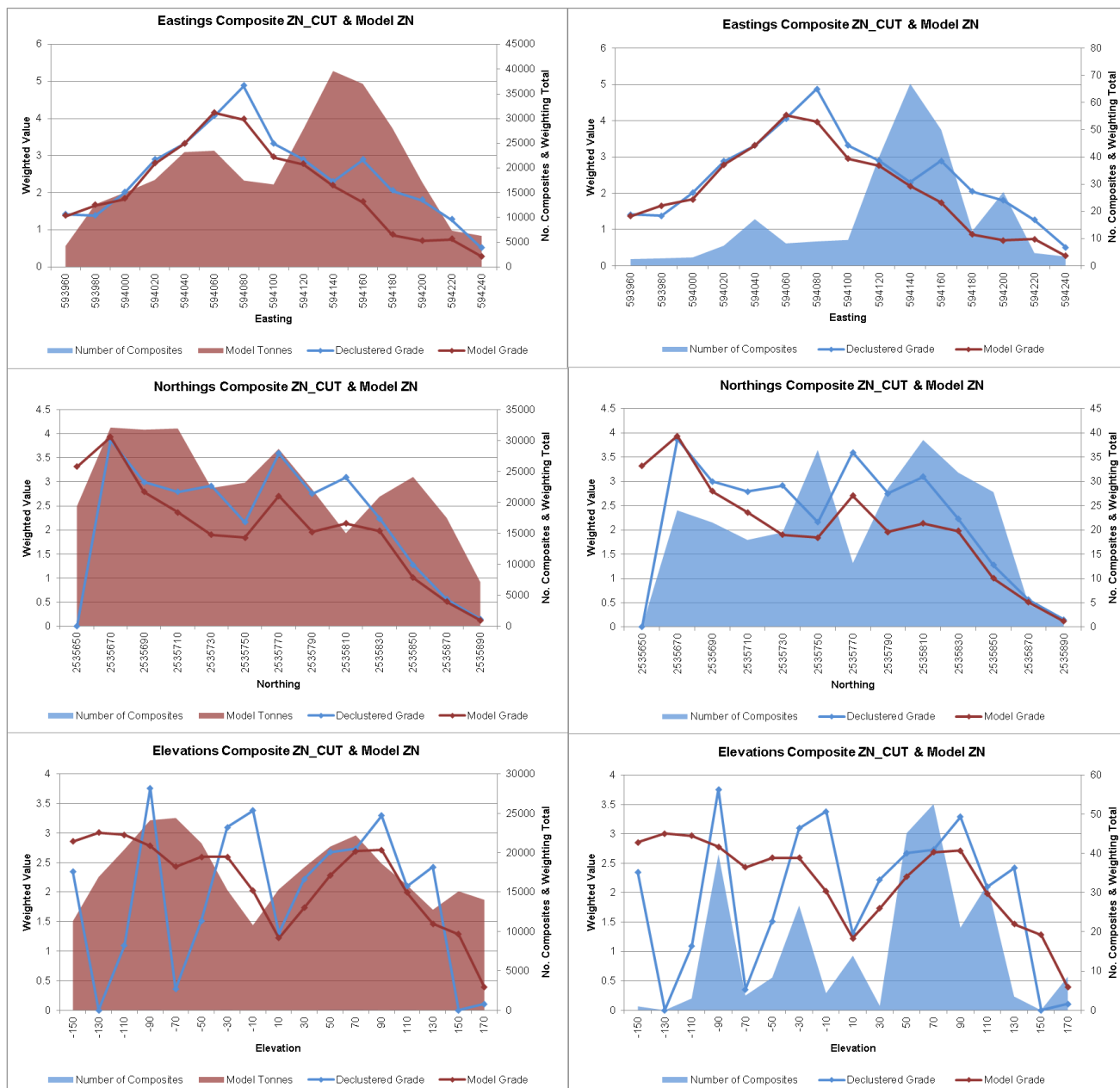

Source: AMC Mining Consultants (Canada) Ltd.

In addition to the standard validation processes AMC has carried out the estimation of 8 veins: V2E, V2W, V9-5, V2-1, V2-3, NV28, V10-1, and V13. The samples were selected inside the wireframes then the grades were capped by the same values as used by GC. After capping the created composites intervals were combined to be equal to the vein intercept's thickness.

The estimation parameters used were close those used in the GC estimation, within the limitation of the different mining software. AMC utilized dynamic anisotropy searches because of the variable strike of the veins. Figure 14.11 shows that the dynamic searches representing continuous grades interpolations on the left side while the GC model have stripes. However, the AMC block model results in slightly higher silver grades than GC models. The comparisons showed that differences

can be up to 5% additional grade in the AMC models, implying that there is some conservatism in the GC models.

Figure 14.11 Vertical section of vein V2E models coloured by silver grades

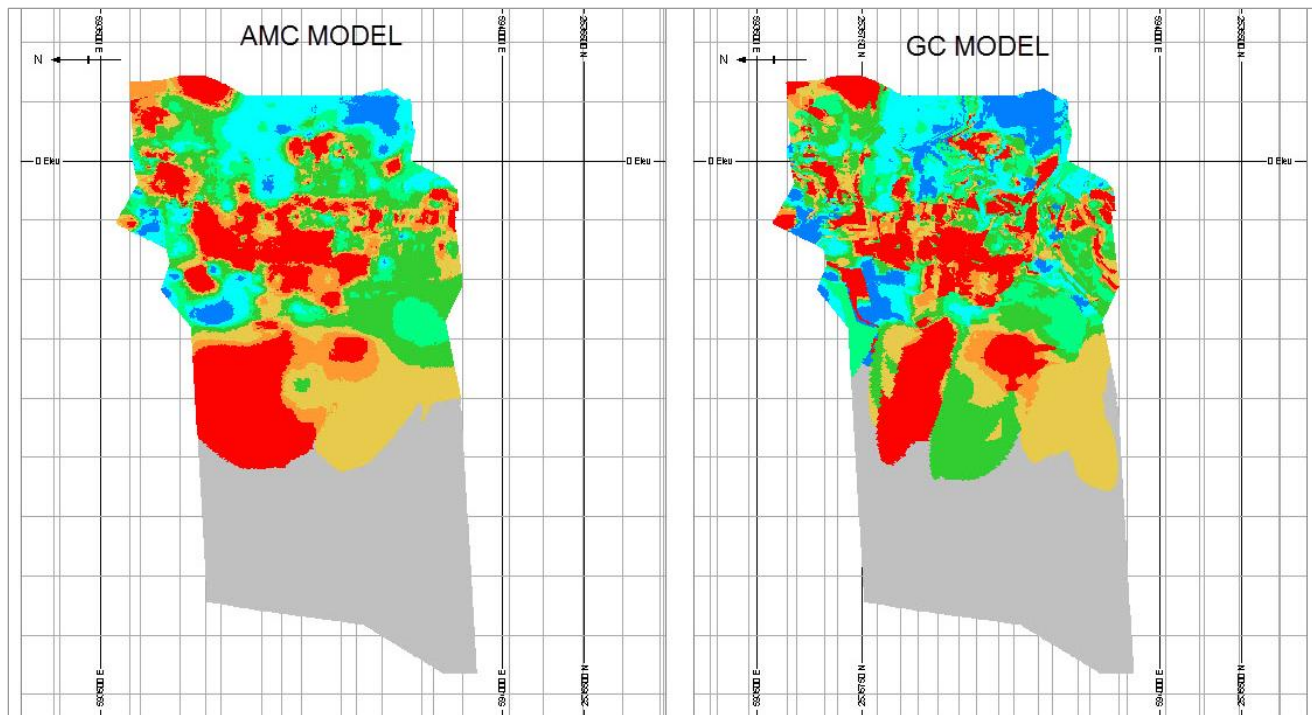

14.5.6 Mineral Resource reporting

Mineral Resource estimates consist of material within the mineralized veins with a silver equivalent cut-off of 100 g/t AgEq. The cut-off value was based on estimated mining costs, processing costs, recoveries, and payables. The cut-off value calculation was generated by AMC with input from Silvercorp. The equivalency formula is $Ag\ g/t + 44.6 * Pb\% + 43.5 * Zn\%$. The multiplication factor for Pb and Zn were derived from equations based on metal prices, recoveries and payable factors.

Input parameters are shown in Table 14.8.

Table 14.8 Input parameters in calculating Mineral Resource cut-off grade

Item	Value	Unit
Silver price	19.0	\$/oz
Lead price	1.00	\$/lb
Zinc price	1.25	\$/lb
Silver recovery	77	%
Lead recovery	86	%
Zinc recovery	83	%
Silver payable	85	%
Lead payable	94	%
Zinc payable	76	%

Source: Silvercorp Metals Inc. and AMC Mining Consultants (Canada) Ltd.

A summary of the Mineral Resource estimates has been shown above in Table 14.1. In Table 14.9 the Mineral Resources for each individual vein are shown.

Note the abbreviations of MS: Measured; ID: Indicated; IF: Inferred; and class meaning Resource Classification.

Table 14.9 Mineral Resources as of 31 December 2017 by each vein at 100 g/t silver equivalent

Class	Vein	Tonnes (t)	Ag (g/t)	Pb (%)	Zn (%)	Vein	Tonnes (t)	Ag (g/t)	Pb (%)	Zn (%)	Vein	Tonnes (t)	Ag (g/t)	Pb (%)	Zn (%)
MS	V2E	388,707	106	1.57	3.17	V10-3	9,682	50	1.44	2.50	V27	8,513	72	0.84	1.70
ID		507,956	84	1.41	3.11		28,964	54	0.91	2.29		10,013	60	0.68	1.94
MS+ID		896,663	94	1.48	3.13		38,646	53	1.05	2.34		18,526	65	0.75	1.83
IF		467,261	135	1.10	2.42		39,379	52	0.63	1.95		108,176	175	0.20	0.73
MS	V9W-2	119,793	129	0.80	2.70	V10-4	13,253	158	2.12	3.98	V28	38,526	91	1.25	2.68
ID		183,464	79	0.73	2.51		34,762	91	1.44	2.86		24,104	85	1.41	2.43
MS+ID		303,256	99	0.75	2.58		48,015	110	1.63	3.17		62,630	89	1.31	2.58
IF		78,798	57	0.67	3.02		49,645	97	1.22	2.07		131,797	54	1.82	2.98
MS	V2W	202,110	113	1.82	3.58	V10E	1,222	16	0.09	2.03	V28-4	91,717	110	1.26	3.21
ID		117,120	75	2.01	3.14		1,222	16	0.09	2.03		75,267	174	1.03	2.81
MS+ID		319,230	99	1.89	3.42		22,421	402	0.90	0.59		166,984	139	1.16	3.03
IF		232,819	81	1.10	3.62							294,103	42	0.90	1.82
MS	V9-5	214,700	85	1.87	3.49	V11	64,307	55	1.51	2.85	V28-4-1	4,325	88	0.30	4.80
ID		131,747	74	1.25	2.22		42,462	22	0.48	3.15		2,310	113	0.25	3.69
MS+ID		346,447	81	1.63	3.00		106,769	42	1.10	2.97		6,635	96	0.28	4.42
IF		83,649	77	1.11	1.73		51,428	19	0.37	2.42		1,061	104	0.19	4.00
MS	V7E	57,686	89	1.77	3.56	V12	26,885	73	0.21	4.95	V29	11,886	34	0.14	3.70
ID		24,562	109	1.51	3.77		52,375	76	0.78	2.94		22,942	116	0.32	3.99
MS+ID		82,248	95	1.69	3.62		79,260	75	0.59	3.62		34,828	88	0.26	3.89
IF		212,211	76	1.28	2.83		80,421	150	0.30	1.73		78,377	169	0.61	2.29
MS	V7-1	109,882	109	0.33	3.26	V13	65,963	62	0.70	2.68	V2E-10	6,761	44	1.06	1.41
ID		81,750	85	1.00	2.23		65,963	62	0.70	2.68		6,761	44	1.06	1.41
MS+ID		191,632	99	0.62	2.82		254,959	62	1.42	3.82		1,122	36	0.64	1.22
IF		165,636	65	0.24	1.78										
MS	V25	21,580	104	1.07	2.12	V14	35,030	133	1.88	4.72	V2E-4	12,541	61	1.45	3.60
ID		39,040	136	1.31	3.20		56,237	108	1.22	2.33		5,530	47	1.04	3.69
MS+ID		60,620	125	1.22	2.82		91,267	118	1.47	3.24		18,071	57	1.32	3.63
IF		100,860	98	1.55	4.17		110,213	163	0.47	1.53		4,934	49	1.94	2.65
MS	V2E1	86,315	140	1.75	2.88	V17	59,902	158	0.84	1.36	V2W-0	12,308	109	0.20	4.18
ID		78,812	82	1.35	3.94		85,076	116	0.54	1.40		12,308	109	0.20	4.18
MS+ID		165,127	112	1.56	3.38		144,978	133	0.66	1.38		3,681	62	0.19	4.07
IF		45,928	46	0.40	2.13		82,703	97	0.53	2.65					
MS	NV10	94,854	50	1.15	3.29	V18	8,844	123	0.51	0.53	V2W-2	0			
ID		79,535	88	1.02	2.23		81,940	170	2.09	0.84		12,570	76	1.13	1.39
MS+ID		174,389	67	1.09	2.81		90,784	165	1.93	0.81		12,570	76	1.13	1.39
IF		120,837	31	0.73	3.02		109,970	101	1.24	0.99					
MS	V1	80,448	52	2.49	3.52	V20					V2W-4	52,020	122	1.17	1.43
ID		84,918	60	2.06	2.57							52,020	122	1.17	1.43
MS+ID		165,366	56	2.27	3.03										
IF		174,063	90	2.31	3.00		9,524	161	6.41	5.40					

Class	Vein	Tonnes (t)	Ag (g/t)	Pb (%)	Zn (%)	Vein	Tonnes (t)	Ag (g/t)	Pb (%)	Zn (%)	Vein	Tonnes (t)	Ag (g/t)	Pb (%)	Zn (%)
MS	V16	161,336	93	0.92	2.61	V2-1	64,442	69	1.20	4.41	V2W-5	31,279	181	1.46	2.24
ID		94,715	102	0.77	2.13		64,442	69	1.20	4.41		31,279	181	1.46	2.24
MS+ID		256,051	97	0.86	2.43		388,359	68	1.40	2.78		12,368	51	1.72	2.78
IF		160,934	162	0.76	2.14		0								
MS	V19	84,567	74	1.18	3.86	V2-2	27,599	78	0.40	2.87	V2W-6	16,411	43	1.97	1.63
ID		77,157	65	0.79	3.71		27,599	78	0.40	2.87		16,411	43	1.97	1.63
MS+ID		161,724	70	1.00	3.79		119,882	57	0.20	2.80		115,529	187	2.79	3.23
IF		121,084	66	0.56	2.77		14,313	67	0.97	3.03		5,965	45	2.61	2.51
MS	V10-1	74,634	88	0.78	5.66	V2-3	13,513	54	0.54	2.31	V30	1,627	49	2.51	1.38
ID		75,002	104	0.88	4.88		27,826	61	0.76	2.68		7,592	46	2.59	2.27
MS+ID		149,636	96	0.83	5.27		20,495	260	1.90	5.33		1,273	24	1.65	0.79
IF		47,658	227	1.52	4.19		9,039	207	0.96	3.41					
MS	NV28	24,395	96	2.00	3.58	V24	29,534	243	1.61	4.74	V30S	23,611	147	0.00	0.65
ID		6,889	77	1.02	3.02		7,969	191	0.92	3.89					
MS+ID		31,284	92	1.78	3.46		89,493	79	1.47	3.61					
IF		5,617	28	0.05	3.44		89,493	79	1.47	3.61					
MS	NV28-1	65,195	95	1.47	3.03	V2-4	145,358	45	0.96	3.08	V31	74,514	54	0.91	1.16
ID		19,908	83	1.12	2.61		24,589	97	1.64	2.25		8,917	74	2.15	3.57
MS+ID		85,103	92	1.39	2.93		45,154	116	0.78	1.67		21,680	77	2.31	2.07
IF		12,489	69	0.54	1.51		69,743	109	1.08	1.87		30,597	76	2.26	2.51
MS	V10	52,094	53	1.77	3.30	V26	90,233	106	0.62	1.11	V32	37,876	63	1.74	1.79
ID		87,219	58	1.09	2.91		5,995	110	0.83	3.92		2,073	72	0.97	0.71
MS+ID		139,313	56	1.34	3.05		481	104	0.85	6.46		7,663	149	1.08	0.67
IF		50,534	57	1.44	2.53		6,476	110	0.83	4.11		9,736	133	1.06	0.68
MS	V33	52,818	84	1.29	1.84	V5-6	115,584	274	1.57	1.60	V8-1	115,584	274	1.57	1.60
ID		52,818	84	1.29	1.84		18,172	101	1.38	5.31		16,697	193	2.41	3.14
MS+ID		52,818	84	1.29	1.84		17,040	72	0.92	4.23		31,062	146	1.87	2.18
IF		126,741	142	1.28	1.68		65,678	39	1.54	2.40		25,247	61	0.54	2.37
MS	V34	14,911	66	0.37	1.50	V6	66,228	121	0.82	2.70	V9-1	66,228	121	0.82	2.70
ID		14,911	66	0.37	1.50		12,437	59	2.73	4.42		72,341	83	0.73	2.36
MS+ID		14,911	66	0.37	1.50		44,342	44	1.96	3.29		138,569	101	0.78	2.52
IF		13,119	98	0.36	1.31		56,779	47	2.13	3.54		49,614	86	0.29	2.79
MS	V36	24,016	91	2.07	3.12	V6-0	247,050	94	0.78	3.07	V9-3	49,614	86	0.29	2.79
ID		4,738	76	1.10	2.53		21,962	61	1.78	2.89		3,109	80	0.71	3.70
MS+ID		28,754	89	1.91	3.03		21,962	61	1.78	2.89		29,668	53	0.79	2.15
IF		7,095	21	0.36	2.14		161,850	110	0.85	4.68		23,174	32	0.32	2.94
MS	V37					V6-1					V9-4				
ID							21,962	61	1.78	2.89		78,052	152	0.57	1.88
MS+ID							21,962	61	1.78	2.89		58,785	142	0.46	1.24
IF		238,498	99	1.36	1.76		161,850	110	0.85	4.68		136,837	148	0.52	1.61
MS	V38					V6-2					V9-9				
ID												16,375	119	0.78	1.13
MS+ID															
IF		32,211	147	1.27	1.69		181,305	151	1.88	2.21		11,930	151	2.66	4.48
MS	V39	7,604	124	0.01	0.11	V6-3					V9W-2E				
ID		7,604	124	0.01	0.11							9,203	151	1.87	3.47
MS+ID		7,604	124	0.01	0.11							21,133	151	2.32	4.04
IF		138,723	97	1.33	3.78		59,854	181	0.95	3.96		11,732	113	1.94	4.40

Class	Vein	Tonnes (t)	Ag (g/t)	Pb (%)	Zn (%)	Vein	Tonnes (t)	Ag (g/t)	Pb (%)	Zn (%)	Vein	Tonnes (t)	Ag (g/t)	Pb (%)	Zn (%)
MS ID MS+ID IF	V4	376,444	178	1.13	1.28	V6-4	57,780	73	3.82	3.82	VH1	127,621	26	1.96	2.57
MS ID MS+ID IF	V40	9,368 28,652 38,020 87,691	191 254 239 131	0.42 1.04 0.89 0.64	1.12 1.23 1.20 3.83	V6-5	6,644 3,082 9,726 66,420	69 49 63 634	0.72 0.47 0.64 2.32	2.35 2.00 2.24 3.70	VH1-1	16,615 16,615 52,237	60 60 58	3.73 3.73 3.93	3.67 3.67 3.56
MS ID MS+ID IF	V41	16,190 16,190 24,085	65 65 41	1.48 1.48 1.24	4.18 4.18 3.64	V6E	119,624	47	0.47	3.42	VH1-3	14,763	63	4.09	4.58
MS ID MS+ID IF	V43	37,471 37,471 26,803	122 122 161	1.58 1.58 0.25	4.61 4.61 2.60	V6M	53,081 53,569 106,650 47,515	50 73 62 146	2.89 4.37 3.64 3.93	2.75 3.39 3.07 5.63					
MS ID MS+ID IF	V44	1,412 348 1,760	92 316 136	1.57 7.63 2.77	2.95 4.76 3.31	V6M-2	16,790 71,469 88,258 88,026	52 64 62 64	2.81 2.50 2.56 2.47	3.04 2.22 2.38 2.44					
MS ID MS+ID IF	V45	2,724 38,144 40,868 26,733	268 203 208 162	0.12 0.89 0.84 0.85	1.20 0.95 0.96 1.11	V7	43,639 46,539 90,177 57,917	90 62 75 85	1.12 0.78 0.94 0.74	2.90 2.60 2.75 2.04					
MS ID MS+ID IF	V5	12,127 69,030 81,157 34,322	106 68 73 73	0.12 0.74 0.65 0.61	5.48 2.65 3.07 4.47	V7-1E	10,812 26,128 36,940 1,412	129 84 97 99	1.29 0.43 0.68 0.62	3.05 2.03 2.33 1.47					
MS ID MS+ID IF	V5-1	11,861 4,935 16,797 3,203	145 77 125 91	0.81 0.37 0.68 0.44	5.97 5.32 5.78 6.30	V7-3	18,494 31,973 50,467 685	117 273 216 365	0.03 0.59 0.38 0.27	3.67 1.77 2.47 0.69					
MS ID MS+ID IF MS	V5-3	11,822 10,578 22,400 7,929	91 191 138 102	0.38 1.12 0.73 0.47	4.22 4.38 4.30 3.23	V7N	28,754 28,754 87,663	31 31 29	0.89 0.89 0.68	2.90 2.90 2.60					
ID MS+ID IF	V5-5	92,608 92,608 92,063	78 78 112	0.43 0.43 1.55	2.46 2.46 3.76	V8	6,801 6,801 34,689	376 376 378	0.22 0.22 1.52	1.60 1.60 1.89					

For comparison, the results of reporting out of the AMC block models at a range of cut-offs for all veins are shown in Table 14.10, with the preferred cut-off shown in bold text. Note due to this table being reported out of the AMC sub-celled models in Datamine, the tonnages are slightly different from those in the actual Mineral Resource estimates reported in Tables 14.1 and 14.9; these differences are not significant.

Table 14.10 Reporting from AMC block models at a range of cut-off values

Resource classification	AgEq cut-off grade (g/t)	Tonnes (t)	Ag (g/t)	Pb (%)	Zn (%)	Contained metal		
						Au (koz)	Pb (Mlbs)	Zn (Mlbs)
Measured	0	3,894,367	76	1.0	2.4	9,561	88	207
	20	3,511,788	84	1.1	2.7	9,506	88	206
	40	3,278,381	89	1.2	2.8	9,412	87	205
	60	3,088,928	94	1.3	3.0	9,290	86	203
	80	2,918,348	97	1.3	3.1	9,142	85	200
	100	2,738,149	102	1.4	3.3	8,945	84	196
	120	2,552,146	106	1.5	3.4	8,703	82	192
	140	2,377,306	110	1.5	3.6	8,442	80	186
	180	2,022,948	120	1.7	3.9	7,785	75	173
Indicated	0	7,873,991	49	0.6	1.4	12,326	105	246
	20	5,783,550	65	0.8	1.9	12,159	104	243
	40	5,056,916	73	0.9	2.1	11,882	103	238
	60	4,479,412	80	1.0	2.3	11,521	101	231
	80	4,031,513	86	1.1	2.5	11,143	98	224
	100	3,610,369	92	1.2	2.7	10,705	95	215
	120	3,213,974	99	1.3	2.9	10,218	91	204
	140	2,890,218	105	1.4	3.1	9,751	88	194
	180	2,346,288	117	1.6	3.3	8,815	80	173
Inferred	0	16,329,834	53	0.6	1.3	27,835	213	481
	20	11,155,740	77	0.9	1.9	27,514	211	476
	40	9,830,768	86	1.0	2.2	27,114	208	466
	60	8,773,584	94	1.1	2.3	26,554	204	453
	80	8,135,111	100	1.1	2.5	26,088	200	442
	100	7,407,263	107	1.2	2.6	25,396	194	426
	120	6,629,800	115	1.3	2.8	24,501	185	405
	140	5,723,211	127	1.4	3.0	23,390	172	376
	180	4,762,647	142	1.5	3.2	21,775	158	337

Sample results up to 31 December 2017.

Source: AMC Mining Consultants (Canada) Ltd., produced based on sub-celled block models.

14.6 Comparison with previous Mineral Resource estimate

The most recently published Mineral Resource estimate on the Property (2012 Mineral Resource estimate) is contained in "NI 43-101 Technical Report on the GC Ag-Zn-Pb Project in Guangdong Province People's Republic of China", effective date 23 January 2012. That estimate included drilling to 31 December 2010. A comparison between the 2012 and 2018 Mineral Resource estimates is shown in Table 14.11. Changes since the 2012 Mineral Resource estimate include:

- 130,810 m underground drilling and 29,163 surface drilling.
- 11,939 m additional sampling underground developments on mineralization.
- Ongoing depletion and sterilization due to mining.
- Updated AgEq and cut-off grades.

- Updated Mineral Resource classification.
- Change of estimation method from polygonal to ID³.
- Change of number of veins from 25 to 89.

Table 14.11 Comparison of Mineral Resources at 100 g/t AgEq cut-off grade

Resource estimate	Resource classification	Tonnes (kt)	Ag (g/t)	Pb (%)	Zn (%)	Contained metal		
						Ag (koz)	Pb (Mlbs)	Zn (Mlbs)
2018 Report	Measured	2,735	101	1.4	3.2	8,840	84	195
	Indicated	3,638	92	1.2	2.7	10,818	98	217
	Measured and Indicated	6,374	96	1.3	2.9	19,658	181	412
	Inferred	7,481	107	1.2	2.6	25,662	196	429
2012 Report	Measured	593	230	1.4	3.3	4,392	19	44
	Indicated	7,039	113	1.3	3.1	25,647	204	475
	Measured and Indicated	7,632	122	1.3	3.1	30,038	222	519
	Inferred	7,960	123	1.4	2.7	31,405	248	467
Difference %	Measured	361	-56	-1	-3	101	342	343
	Indicated	-48	-19	-8	-13	-58	-52	-54
	Measured and Indicated	-16	-21	0	-6	-35	-18	-21
	Inferred	-6	-13	-14	-2	-18	-21	-8

Notes for the 2012 Mineral Resource estimate:

CIM Definition Standards (2010) were used for reporting the Mineral Resources.

Mineral Resources are estimated at a resource silver equivalent cut-off value of 100 g/t.

Silver equivalent calculation was based on metal prices of \$18/oz Ag, \$1.0/lb Pb, and \$1.00/lb Zn and estimated recoveries of 62.78% Ag, 84.57% Pb, 88.42% Zn.

Drilling results up to 31 December 2010 and date of Mineral Resource 31 December 2011.

The numbers may not compute exactly due to rounding.

Notes for the 2018 Estimate:

See notes on Table 14.1 with respect to the 2018 Mineral Resource estimate.

The following observations have been made by the QP from the table comparing the 2012 Mineral Resource estimate with the 2018 Mineral Resource estimate:

- Measured and Indicated tonnes have decreased by 16%. This number is a combination of mining depletion (negative impact) and change in classification method (positive impact on Measured tonnes). The Inferred resource decreased by 6%.
- In the Measured category silver grade have decreased by 56% and lead and zinc grades have decreased by 1% and 3% respectively.
- In the Indicated category silver grades have decreased by 19%, lead and zinc grades have decreased by 8% and 13% respectively.
- In the Inferred category the grades have decreased for silver, lead, and zinc by 13%, 14% and 4% respectively.
- The net result in the Measured category has been a significant increase in the contained metals, due to the increase in tonnes. Silver metal increased by 101% and both lead and zinc contained metal have increased by approximately 340%.
- The net result in the Indicated category has been a decrease in the contained silver metal by 58%, lead and zinc contained metals have decreased by 52% and 54% respectively.
- The net result in the Inferred category has been a decrease in the contained silver metal of 18%, contained lead metal have decrease by 21% and contained zinc metal have decreased by 8%.

Reasons for the differences in grade, tonnes and contained metal include:

1. 3D interpretation of the veins.
2. A different estimation approach and parameters, including different capping levels and strategy.
3. A different classification strategy.
4. Depletion through mining.

14.7 Recommendations

AMC recommends the following:

- Collect additional bulk density samples to represent various ore types including low grade, medium grade, high grade and waste material.
- Use of a dynamic anisotropy search or to increase the search radius of the ellipse across the veins, to improve grade continuity within the estimation.
- Continue to use the revised AMC approach to Mineral Resource classification which is based on estimation criteria and manual adjustments where appropriate. This eliminates outliers.
- That future modelling of GC deposit is completed as a single block model as opposed to individual block models for each vein.

15 Mineral Reserve estimates

15.1 Introduction and Mineral Resources base

The Mineral Resources upon which the Gaocheng Mineral Reserves are based have been discussed in detail in Section 14. The Mineral Resources are located in areas where Silvercorp has mining permits.

To convert Mineral Resources to Mineral Reserves, mining cut-off grades have been applied, mining dilution has been added and mining recovery factors assessed on an individual vein mining block basis. Only Measured and Indicated Resources have been used for Mineral Reserves estimation.

The Mineral Reserve estimates for the Gaocheng property were prepared by Silvercorp under the guidance of independent Qualified Person, Mr H. Smith, P.Eng., who takes QP responsibility for those estimates.

15.2 Mineral Reserve estimation methodology

The Mineral Reserve estimation is based on the assumption that current stoping practices will continue at the Gaocheng property, namely predominantly shrinkage stoping but also with a relatively small amount of cut and fill resuing, using hand-held drills and hand-mucking within stopes, and loading to mine cars by rocker-shovel or by hand. Minimum mining widths of 1.0 m for shrinkage and 0.5 m for resuing are assumed. AMC has observed the shrinkage mining method at the Gaocheng property and the application of cut and fill resuing at the Silvercorp Ying property and considers the minimum extraction and mining width assumptions at Gaocheng to be reasonable. Minimum dilution assumptions are 0.2 m of total overbreak for a shrinkage stope and 0.10 m of total overbreak for a resuing cut and fill stope. Dilution is discussed further in Section 15.4.

For the total tonnage estimated as Gaocheng Mineral Reserves, 81% is associated with shrinkage and 19% with resuing.

15.3 Cut-off grades

Mineral Reserves have been estimated using Silver Equivalent (AgEq) cut-off grade values for shrinkage and resuing. The cut-off grade bases (full breakeven and marginal material) are summarized below and in Table 15.1.

In situ AgEq (g/t) = 44.6 x Pb% + 43.5 x Zn% + Ag g/t, where the respective factors for Pb and Zn are calculated as (value of 1% metal after application of metallurgical recovery and payable metal) divided by (value of 1 g silver after application of metallurgical recovery and payable metal).

AgEq Cut-off grade, AgEq (g/t) (full breakeven) = (mining cost + exploration & drilling cost + milling cost + G&A + sustaining capital + Mineral Resources tax) / (\$ value per in situ gram after application of mining recovery, metallurgical recovery & payable).

AgEq Cut-off grade, AgEq (g/t) (marginal material) = (mining cost + milling cost + G&A + sustaining capital + Mineral Resources tax) / (\$ value per in situ gram after application of mining recovery, metallurgical recovery & payable).

In determining metal prices for use in the cut-off calculations (and Mineral Resource / Mineral Reserve estimation and economic evaluation), AMC has referenced three-year trailing averages, prices current as of April 2018, prices used in recent NI 43-101 reports, and available consensus forecast information. The exchange rate used was 6.5 RMB = US\$1.

Table 15.1 Mineral Reserve cut-off grades and key estimation parameters

Item	Gaocheng Mine	
	Shrinkage	Resuing
Foreign exchange rate (RMB:US\$)	6.5	6.5
Operating costs		
Mining cost (includes development & exploration) (\$/t)	37.37	63.56
Milling cost (\$/t)	15.69	15.69
G&A and product selling cost (\$/t)	7.41	7.41
Sustaining capital (\$/t)	3.63	3.63
Mineral Resources tax (\$/t)	3.21	3.21
Total operating costs (US\$/t)	67.31	93.50
Mining recovery (%)	92	95
Mill recoveries		
Ag (%)	77	77
Pb (%)	86	86
Zn (%)	83	83
Breakeven COG (AgEq g/t)	180	245

Metal price assumptions: Ag \$19/oz; Pb \$1.00/lb; Zn \$1.25/lb.

A lower cut-off grade value of 145 g/t AgEq has been used for the small amount of marginal material considered for inclusion in the Mineral Reserves estimate. This cut-off value is considered for operational areas where, effectively, all exploration and associated drilling expenditures have already been accounted for.

15.3.1 AMC comment on cut-off grades

AMC considers that the Mineral Reserve cut-off grades and their supporting parameters are reasonable. AMC also notes that the Gaocheng Mineral Reserves as a whole have relatively limited sensitivity to variation in cut-off grade, showing a 6% reduction in metal content for a COG increase of 10%.

15.4 Bulk density

Mineral Resource estimates use a bulk density of 3.57 t/m³, which is assumed constant for all veins and areas. AMC notes that the grade and relative distribution of the three key payable elements: Ag, Pb, and Zn, can vary significantly (>10%) from vein to vein, but does not consider the potential impact of varying grade on density to be material (<5%) on the Mineral Resource and Mineral Reserve tonnage estimates.

Waste density assumed for dilution estimation purposes is 2.64 t/m³.

15.5 Dilution and recovery factors

15.5.1 Dilution

As indicated above, minimum mining widths are assumed as 1.0 m and 0.5 m respectively for shrinkage and resuing. For shrinkage, a minimum dilution factor of 0.2 m is added to the minimum vein width of 0.8 m. For resuing, a dilution factor has been applied to each true vein width up to a minimum extraction width of 0.5 m or to (vein width plus 0.1 m) where the true width is greater than 0.4 m. AMC notes that, for Silvercorp narrow vein operations generally, a key strategy for minimizing floor dilution is the placement of rubber mats and / or conveyor belting over the waste

fill floor in resuing stopes immediately before each resuing blast. This effectively serves as a barrier between ore and waste.

The dilution calculation process used for the Mineral Reserves assumes that the resulting figures represent the overall tonnes and grade delivered to surface. There is a small degree of waste hand sorting, and therefore upgrading that occurs underground. AMC considers that the resulting impact of this hand-sorting on the delivered product is not significant enough to be material.

AMC notes that the projections for dilution in both shrinkage and resuing stopes assume a high degree of process control in terms of design, drilling and blasting, and that such control on an ongoing basis will be critical to achieving dilution targets.

Table 15.2 summarizes average dilution from the Mineral Reserve calculations for each mining method. Comparing with estimated dilution values in the 2012 Technical Report, there is a significant increase (~30%) in estimated dilution for shrinkage but an even more significant decrease (~47%) in that estimated for resuing. AMC considers that the current overall dilution estimation is reasonable considering realized production grades to date relative to those of Mineral Reserves mined. AMC also again notes the dominance of shrinkage mining in the current Mineral Reserves (wider veins) but also cautions that, as with most narrow vein operations, a particular focus on minimizing dilution via mining process control will be important in realizing Mineral Reserve grades in the future.

Table 15.2 Average dilution by mining method

Gaocheng Mine	Dilution %
Shrinkage	14
Resuing	13
Total dilution Gaocheng	13

15.5.2 Mining recovery factors

Mining recovery estimates used in the Mineral Reserve calculations are based on experience at the Gaocheng site and Silvercorp operations as a whole. For shrinkage stopes, 92% total recovery is assumed; for resuing stopes, 95% total recovery is assumed. Minimal pillars are anticipated to remain between adjacent mining blocks in the same vein, and partial recovery in sill pillars is allowed for in the respective recovery factors.

15.6 Mineral Reserve estimate

To convert Mineral Resources to Mineral Reserves, Silvercorp uses the following procedures:

- Selection of Measured and Indicated Resource areas (potential stope blocks) for which the average AgEq grade is greater than the mine cut-off AgEq grade.
- Application of minimum extraction and mining width criteria and calculation of dilution at zero grade.
- Estimation of Mineral Reserve potential by applying relevant mining loss factors.
- Reconfirmation that diluted AgEq grade is greater than mine cut-off.
- Confirmation as Mineral Reserves by considering any other significant cost factors such as additional waste development required to gain access to the block in question.
- Inclusion of marginal material where, in an operations scenario, the material in question will at the very least recover costs directly associated with that material and will be transported to the mill for processing.

Table 15.3 summarizes the Mineral Reserve estimates for the Gaocheng mine. 47% of the Mineral Reserve tonnage is categorized as Proven and 53% is categorized as Probable.

Table 15.3 Gaocheng mine Mineral Reserve estimate at 31 December 2017

Reserve classification	Tonnes (kt)	Ag (g/t)	Pb (%)	Zn (%)	Contained metal		
					Ag (koz)	Pb (Mlbs)	Zn (Mlbs)
Proven	1,691	96	1.4	3.2	5,219	53	120
Probable	1,873	97	1.4	2.9	5,841	58	121
Proven and Probable	3,564	96	1.4	3.1	11,000	112	240

Notes to Mineral Reserve Statement:

Full breakeven cut-off grades: Shrinkage = 180 g/t AgEq; Resuing = 245 g/t AgEq.

Marginal material cut-off grade: 145 g/t AgEq.

Dilution (zero grade) assumed as 0.1 m on each wall of a shrinkage stope and 0.05 m on each wall of a resuing stope.

Mining recovery factors assumed as 95% for resuing and 92% for shrinkage.

Metal prices: Silver US\$19/troy oz, lead US\$1.00/lb, zinc US\$1.25/lb

Processing recovery factors: Ag - 77%, Pb - 86%, Zn - 83%

Effective date 31 December 2017.

Exchange rate assumed is RMB 6.50:US\$1.00.

Rounding of some figures may lead to minor discrepancies in totals.

From the start of commercial operations at Gaocheng in 2014 through to 31 December 2017, 988,000 tonnes have been mined at average head grades of 98 g/t silver, 1.5% lead and 2.7% zinc. Compared to the head grades for Gaocheng production to date, the current Mineral Reserve estimates show a reduction in silver grade of 2%, a reduction in lead grade of 5%, and an increase in zinc grade of 13%. These differences are relatively small and largely within the margin of estimation error but may also reflect the mining plan generally moving into deeper areas in the mine. An increase in zinc grade may also be seen to fit with the role of zinc as the current major value metal at Gaocheng.

15.7 Conversion of Mineral Resources to Reserves

Table 15.4 compares the respective values of Measured plus Indicated Resources and Proven plus Probable Reserves for Gaocheng.

Table 15.4 Resources and Reserves comparison

Gaocheng		Mineral Resources			Mineral Reserves			Conversion factor*		
		Measured	Indicated	M + I	Proven	Probable	P + P	Meas / Prov	Ind / Prob	M+I/P +P
Tonnes	mt	2.735	3.638	6.374	1.691	1.873	3.564	62%	51%	56%
Silver	g/t	101	92	96	96	97	96	59%	54%	56%
Lead	%	1.4	1.2	1.3	1.4	1.4	1.4	63%	61%	61%
Zinc	%	3.2	2.7	2.9	3.2	2.9	3.1	62%	56%	59%

Notes: *Tonnes and metal content.

Numbers may not compute exactly due to rounding.

Total Mineral Reserve tonnes are approximately 56% of Mineral Resource (Measured plus Indicated) tonnes. The tonnage conversion from Measured to Proven is 62% and that for Indicated to Probable is 51%. Metal conversion percentages for silver, lead, and zinc are 56%, 61%, and 59% respectively.

15.8 Comparison of 2018 and 2012 Mineral Reserve estimates

Relative to the Mineral Reserve estimates in the previous Technical Report (2012 Technical Report - pre-operations), there is a 264% increase in Proven Mineral Reserve tonnes and a 56% decrease

in Probable Mineral Reserve tonnes, with a decrease in Mineral Reserve total tonnes of 25% (1,186,000 t). Tonnes and grades for the respective Mineral Reserves estimates are shown in Table 15.5.

Table 15.5 Comparison of 2018 and 2012 Mineral Reserve estimates

Reserve estimate	Reserve classification	Tonnes (kt)	Ag (g/t)	Pb (%)	Zn (%)
2018 Report	Proven	1,691	96	1.4	3.2
	Probable	1,873	97	1.4	2.9
	Proven and Probable	3,564	96	1.4	3.1
2012 Report	Proven	464	199	1.1	3.2
	Probable	4,286	113	1.3	2.9
	Proven and Probable	4,750	121	1.3	3.0
Difference %	Proven	264	-52	25	1
	Probable	-56	-14	5	-1
	Proven and Probable	-25	-21	7	5

Notes to Mineral Reserve Statements:

See Table 15.3 for 2018 Mineral Reserve notes.

For 2012 Mineral Reserves: Metal prices used: silver US\$18.00/troy oz, lead US\$1.00/lb, zinc US\$1.00/lb

Cut-off grade, 135 g/t AgEq.

Rounding of some figures may lead to minor discrepancies in some totals

16 Mining methods

16.1 Conventions

All measurement units in this report are metric SI units.

The GC project has a local mine section grid (Mine Section) orientated at 200° – 20° bearing whereby the section numbers increase with easting and the section spacing is at 50 m intervals between even numbered sections (e.g. Sections 10 to 12 is a 50 m interval).

16.2 Introduction

Mining to date has been conducted in two stages, with a general description as follows:

1. Stage 1 - +150 mRL to -50 mRL between local Mine Sections 10 to 36 for development and 12 to 32 for production. West side of project.
2. Stage 2 - +100 mRL to -50 mRL between Mine Sections 36 to 54 for development and 32 to 54 for production. For -50m RL to -300 mRL between Mine Sections 12 to 50 for both development and production.

Stage 1 essentially targeted bringing the project into production as soon as practicable using mobile rubber-tired diesel-powered equipment (development jumbo, loader and truck) with surface declines access down to -50 mRL.

Stage 2 development from -50 mRL down to -300 mRL employs conventional tracked equipment (battery powered locomotives, rail cars, electric rocker shovels and pneumatic hand held drills) via a surface shaft access.

Selective stoping methods - shrinkage and resuing - are employed with stope production drilling conducted with pneumatic jackleg drilling. In-stope rock movement is by gravity to draw points or hand-carting to steel-lined passes.

Stage 1 production mucking used load-haul-dump loaders (LHD) with trucks hauling ore to the surface ROM stockpile, and ore was re-handled from the ROM stockpile to the primary crusher feed bin using a ROM front-end-loader (FEL).

Stage 2 and ongoing production mucking uses electric-powered over-throw rail loaders with rail cars and battery powered locomotives transporting ore to level ore passes at each level. Ore is hoisted using a double-story cage (holding four cars, i.e. two cars each story) to a surface stock pile where a loader conveys ore to the surface crusher feed bin.

16.3 Geotechnical conditions

16.3.1 Introduction

AMC's geotechnical review included the following:

- Review of existing available data including RQD and reports provided by Silvercorp.
- Preliminary characterization of rock mass conditions based on available geotechnical data.
- Preliminary assessment of ground support requirements for lateral mine development.
- Review of mine design parameters including stope spans and pillar dimensions.

Presented within this section is a summary of the methodology and results of the various geotechnical assessments undertaken, and recommendations for further work as appropriate.

It is noted that, due to the limited geotechnical data at the time of the assessment, which was prior to significant development at Gaocheng, AMC's review is considered high-level and not to the level of detail normally associated with a mining operation in Canada. As such, AMC's geotechnical review incorporated preliminary assessments aimed at assessing the "reasonableness" of the geotechnical aspects of the initial mine design.

No updated specific geotechnical or hydrogeological study data is available for the GC mines. In general, the ground at current mining levels is in good condition, which is similar to development and mining operations experience to date. The excavation of relatively small openings, both in development and stoping, facilitates ground stability. Support is only installed where deemed to be necessary, with rockbolts being used for hangingwall support on occasion and shotcrete for decline or permanent excavations. Timber and steel I-beams are also used where unstable ground is encountered.

As shrinkage stope void volumes increase, ground instability associated and hanging wall failure may occur.

No geotechnical simulation software such as Map3D is used at GC. The mining sequence is usually planned in accordance with engineering and operational experience.

16.3.2 Available data

AMC's initial geotechnical assessments were conducted in May 2011, based upon site observations made during a site visit to the GC Project by Owen Watson (AMC Senior Geotechnical Engineer), together with reports and data provided by Silvercorp.

As part of the site visit, geotechnical observations were made of the following:

- Rock mass exposures in portal areas of previously mined adits ML-5 and ML-8.
- Selections of core from drillholes ZK1401, ZK1001, ZK40204, and ZK101.

The following data was provided by Silvercorp:

- GMADI Report: 'Mining and Dressing Project of Gaocheng Lead-Zinc Ore in Yun'an County, Guangdong Province - Preliminary Design (GD1371CS) Volume I', January 2011.
- Detailed geotechnical interval data of Q-System rock mass classification parameters (after Barton et al, 1974) from two drillholes (ZK2002 and ZK3604) collected by Silvercorp.
- RQD logging data from 35 drillholes collected by Silvercorp. RQD data had been recorded in long intervals based on lithological units, rather than shorter intervals based on drilling runs. As a result, the data provided an indication of the overall rock quality for the entire lithology unit, but detail on the variation of RQD within the logged lithology unit could not be determined.
- Additional geotechnical data including degree of weathering, compressive strength and rock quality index data. The compressive strength data and rock quality index data were not directly used for the analysis as AMC was unable to establish the specific procedures used to obtain the data, and therefore could not determine its reliability.
- Wireframe interpretations of the mineralized veins.
- Wireframe of underground geological structures.
- Wireframe of surface topography.
- Drillhole database with partial geotechnical logging data.

16.3.3 Data analysis

AMC's analysis of the geotechnical logging data involved the following:

- Generation of sections (on 250 m spacing, looking west) showing RQD histograms plotted along drillhole traces, to investigate the spatial variation in RQD values relative to the mine design and interpreted veins. RQD was plotted as '100-RQD' in order that zones of lowest RQD values are displayed as the tallest histograms. Presented in Figure 16.1 is a north-south section located towards the western limit of the mine design showing RQD histograms. Low RQD values appear to be generally related to weathered material near surface and locally throughout the rock mass, possibly related to veins and / or vein contacts.
- Generation of distribution plots of the logged rock mass classification parameters to investigate the statistical distribution of the logged parameters for each of the main geotechnical domains. The distribution plots for 'all data' are shown in Figure 16.2.
- Generation of distribution plots of RQD logging data for each of the main geotechnical domains. These plots are presented in Figure 16.3.

Figure 16.1 Section looking west at 93500 mE, showing '100-RQD' histograms plotted on drillhole traces

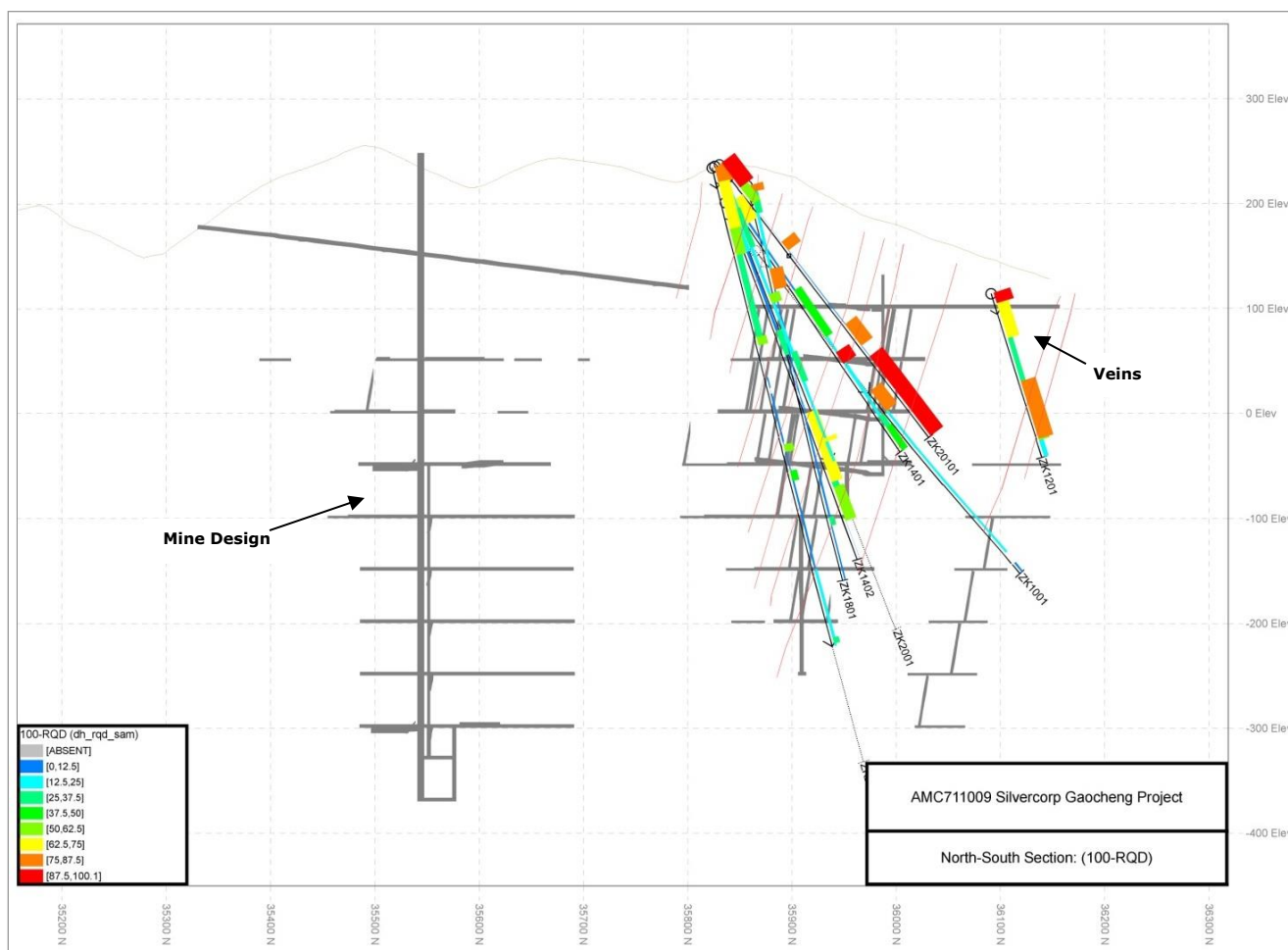

Figure 16.2 Distribution analysis for all geotechnical logging data

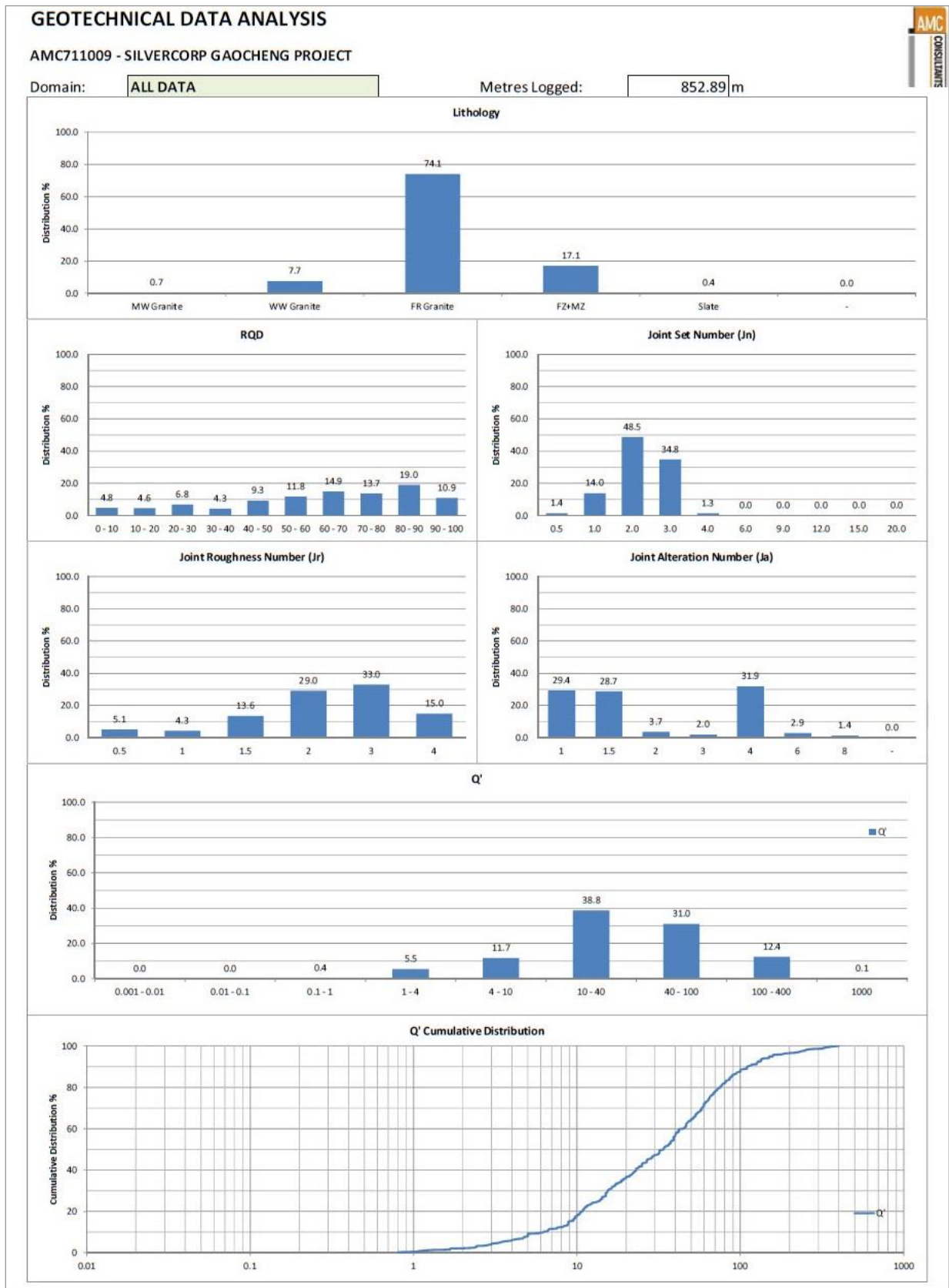
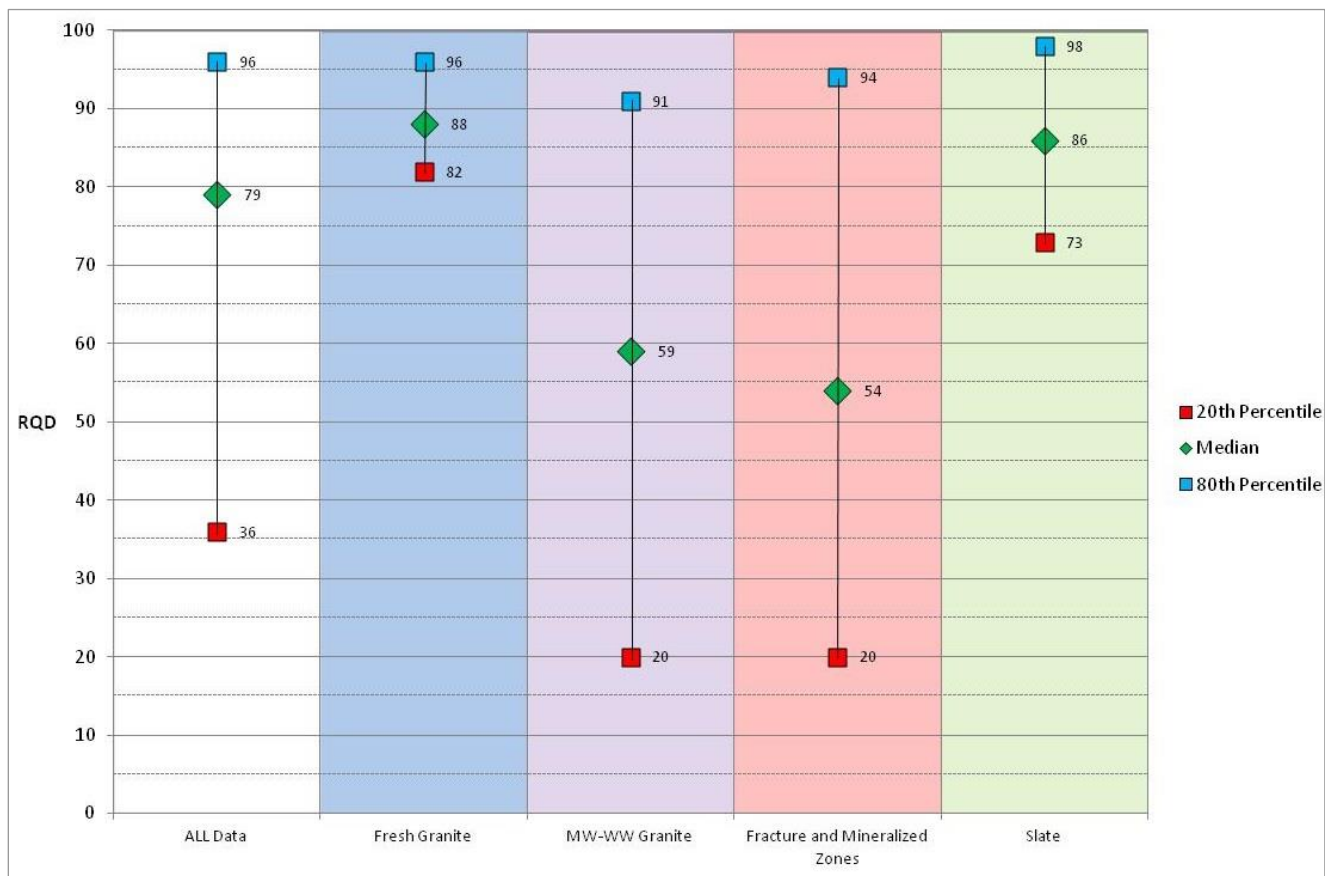

Figure 16.3 RQD data distribution



16.3.4 Characterization of geotechnical conditions

Geotechnical domains were assigned according to lithology and degree of weathering as follows:

- Moderately and weakly weathered granite.
- Fresh granite.
- Fracture and mineralized zones.

These domains were considered 'preliminary' based on the limited available geotechnical data. Collection of additional data could result in definition of additional geotechnical domains, particularly in the immediate hangingwall of the veins, where there is currently insufficient detailed specific geotechnical information, and also beyond the footwall contact of the vein system in which there is limited drilling coverage. Geological logging of existing drill core indicates the presence of an argillaceous slate unit beyond the footwall of the veins, however there is insufficient geotechnical data to characterize rock mass conditions in the slate.

Depth of weathering is variable across the project area. Completely to Highly Weathered material generally extends up to approximately 20 m below surface, with Moderate to Weakly Weathered Granite extending to depths of approximately 100 m.

AMC notes that Fresh Granite forms the primary host rock of mineralization and is the domain in which the majority of waste development has occurred to date and is likely to occur in future.

Mineralized veins that comprise the orebody have been included in the domain 'Fracture and Mineralized Zones'.

The 'Q' rock mass classification parameters (after Barton et al, 1974) which characterize expected rock mass conditions within each domain are summarized in Table 16.1. These values are based on the geotechnical logging data provided by Silvercorp, and observations of drill core made by AMC during its 2011 site visit. It should be noted that AMC increased the logged values of Joint Set Number for all rock types by one joint set based on observations made during the 2011 site visit. It should also be noted that there was no specific geotechnical component to the 2018 site visit but that ground conditions were observed to be generally good.

Table 16.1 Rock mass classification parameters by geotechnical domain

Domain	Moderate to weakly weathered granite	Fresh granite	Fracture and mineralized zones
RQD	20% to 60%	80% to 90%	20% to 50%
Joint Set Number (Jn)	2 to 3 Joint Sets (Jn = 4 to Jn =9)	2 to 3 Joint Sets (Jn = 4 to Jn =9)	2 to 3 Joint Sets (Jn = 4 to Jn =9)
Joint Roughness (Jr)	Smooth to Rough, Undulating (Jr = 2 to Jr = 3)	Rough and Planar to Smooth and Undulating (Jr=1.5 to Jr=2)	Rough and Planar to Smooth and Undulating (Jr = 1.5 to Jr = 2)
Joint Alteration (Ja)	Hard, non-softening coating to soft, sheared coating (Ja = 1.5 to Ja = 4)	Hard, non-softening coating to soft, sheared coating (Ja = 1.5 to Ja = 4)	Non-softening coating to soft, sheared coating (Ja = 2 to Ja = 4)
Rock Mass Classification	Poor to Good rock mass quality	Poor to Good rock mass quality	Poor to Fair rock mass quality

16.3.5 In situ stress

No specific data was available for the study regarding *in situ* stresses at the project. However, the GMADI report states that direction and magnitude of major principal stress is expected to be consistent with dead-weight loading of overburden. This assumption formed the basis for estimating mining induced stresses as part of stope stability and ground support assessments presented below.

16.3.6 Hydrogeology

AMC has not conducted any specific hydrogeological investigations for this study. The GMADI report presents discussion of hydrogeological conditions at the project and states that hydrogeological exploration in the district is relatively inadequate. For AMC's preliminary geotechnical assessments, minor water inflows (less than 5 litres per minute locally) were assumed.

AMC notes that operating experience to date indicates that the assumption of minor water inflows is reasonable.

16.3.7 Mine design considerations

16.3.7.1 Rock mass conditions

The rock mass condition is categorized as Fair to Good and the AMC assessment anticipated that the vein and host rocks in the mine area would generally be competent and require minimal ground support. This has largely been confirmed in operations, with most areas deemed to require little or no support. Where Poor ground conditions have been encountered, ground support is provided, with a range of strategies available depending on the local situation. This may be either rock bolts with or without mesh, shotcrete only, shotcrete with rock bolts, shotcrete with rock bolts and mesh, timber or heavier steel support.

AMC notes that the surface shafts collar has traversed approximately 10 m of soil coverage and 20 m of oxidized ground.

16.3.7.2 Surface requirements

AMC understands that surface subsidence is not permitted at the GC Project. The GMADI design incorporated a surface crown pillar with the upper stoping limit set at +100 mRL. The local topography above the mine plan area varies between approximately 105 mRL (at river level) to 340 mRL (hill top).

The Hashui Creek traverses the north-eastern portion of the mine area inside the Stage 1 and Stage 2 potential subsidence zones between mine Sections 26 to 56. The river is diverted via a tunnel (579 m) to the north-east to fall outside of the Stage 2 potential subsidence zone. The river tunnel diversion was implemented prior to Stage 1 production commencing.

AMC considered that the allowance for the surface crown pillar made in the design was generally appropriate. AMC also recommended, and reaffirms that recommendation, that a detailed investigation and assessment of crown pillar requirements be undertaken for input into the detailed mine design with particular focus on surface pillar requirements in the vicinity of Hashui Creek valley, and any other streams (or drainage paths) that traverse the mine area.

16.3.7.3 Stability assessment for stoping

A preliminary stability assessment of the proposed shrinkage stoping configuration was undertaken using the Modified Stability Graph method as described by Hutchinson and Diederichs (1996). The input parameters used for the assessment were based on median rock mass conditions estimated from distribution plots of geotechnical logging data.

The proposed shrink stoping layout (which largely reflects what has been undertaken in operations) consisted of mining panels 50 m in length on strike, and 50m in height, resulting in a hangingwall with hydraulic radius (HR) of 12.5. Each shrink stope remains filled with broken ore until excavation is completed to full height, at which time the broken ore is removed from the stope via cross-cut drawpoints established on the mucking horizon. During this stage, some secondary dilution is anticipated. On completion of production, the stope remains open and unfilled.

AMC understands that Silvercorp has previously considered the application of a pastefill system to fill some of the mined out stopes.

AMC's preliminary assessment indicated that an open stope hangingwall of HR=12.5 is at the upper limit to achieve stability without the requirement for cable bolt support. Because ground conditions were anticipated to be variable (locally better or worse than the median values used for the assessment), instances of local hangingwall instability were expected. Hangingwall instability can result in unacceptable levels of dilution of the broken ore stocks, or loss of ore within the stope. Based on AMC's limited understanding of the variability of the rock mass conditions, the average allowance for dilution presented in Table 15.3 was considered reasonable.

Shrink stope end walls and back were forecast to be stable without requirement for cablebolt support for the majority of expected rock mass conditions.

It is noted that this assessment was concerned with the 'rock mass' and did not consider possible destabilizing effects associated with major structures such as faults or shear zones. These should be considered on a case by case basis.

16.3.7.4 Stope pillars

Stope crown pillars for both shrinkage and resue stopes were envisaged to be approximately 3 – 5 m in height on-dip at the prevailing mining width and vein dip.

For the Shrinkage stoping method the travel way access pillars were anticipated to be approximately 3 m height on-dip by 2 m width on-strike for the prevailing mining width and vein dip.

For the Resue stoping method a secondary sill pillar was projected to be employed (located above the vein drive which is at the access level elevation), at approximately 3 m in height on-dip at the prevailing mining width and vein dip.

Based on AMC's understanding of the rock mass conditions and the generally narrow mining widths envisaged, the pillar allowances were considered reasonable, with operating experience to date generally confirming the same. As with all mining operations, however, variability of rock mass conditions may dictate that, locally, larger pillars are necessary where Poor rock mass conditions are encountered. In addition, as mining progresses to greater depths, increases in *in situ* and mining induced stresses may also result in the requirement for larger pillars.

16.3.7.5 Main shaft pillar

A pillar is to be maintained around the Main Shaft. Development may occur within the pillar zone; however, stope production will not be allowed. The shaft pillar is an expanding conical with depth from the collar elevation at an 80° dip. AMC's understanding is that the radius of the pillar at surface (248 mRL) is 13 m and the Main Shaft radius is 3 m.

16.3.7.6 Ground support requirements

Indicative ground support requirements were estimated for the lateral development using the Q-system (after Barton, Lien and Lunde, 1974) and the Tunnelling Support Guidelines developed by Grimstad and Barton (1993).

Assessments were conducted for each geotechnical domain for median and lower 20th percentile rock mass conditions estimated from distribution plots of geotechnical logging data.

Based on AMC's experience, where drift development is by conventional drill and blast methods, installing a minimum standard of ground support on a round by round basis in all mine development is the most effective and reliable method of reducing the exposure of mine personnel to rock fall hazard, particularly at the working heading. This is the approach AMC recommends for any new mine, regardless of the mine's location and local mining practices.

However, AMC understands that in general, the mine development at the GC project has been and will be left unsupported unless ground conditions warrant otherwise - as is common mining industry practice in China. AMC's ground support assessment indicated that, for the relatively small dimensioned drift development proposed, excavations were anticipated to be stable without installation of support for the majority of expected rock mass conditions; this has generally been borne out in operations to date. Where Poor ground conditions are encountered, the assessment indicated that pattern bolting on a spacing of 1.5 m and shotcrete support (50 - 70 mm thickness) would be necessary.

In lieu of installing ground support in all underground development on a round by round basis, AMC made, and continues to make, the following recommendations:

- Assess ground conditions on a round by round basis in all development headings (ore and waste) to determine the requirement for ground support. Doing so helps prevent the

occurrence of significant failures from backs and walls, which require timely rehabilitation and expose the work force to rock fall hazard.

- Ensure scaling of the development heading on a round by round basis.
- Conduct routine check scaling of all unsupported development at the mine. This process can help identify areas of the mine in which rock mass deterioration is occurring and allow rehabilitation works to be planned.
- Where possible, avoid mining development intersections in fault zones, and design drifts to cross fault zones at right angles (to minimize the exposure length within the drift).

In addition to the above, AMC recommends that specific rock mass conditions be assessed for critical underground infrastructure, including shafts and chambers, to determine ground support requirements to ensure serviceability of the excavation for the life of mine.

16.3.7.7 Conclusions

Based on the review of the available geotechnical data and high-level assessments undertaken, AMC considered that the geotechnical aspects of the GMADI mine design were generally reasonable for mining study purposes. However, given the limited nature of the data, the geotechnical knowledge at the project prior to commencement of operations was not considered to be at the level of detail normally associated with a mining operation or feasibility study in Canada. That geotechnical knowledge has, at the practical level, been significantly advanced since the commencement of operations.

Further geotechnical investigations were previously recommended to advance the mine design to an 'executable design'. In particular, AMC recommended that the following work be undertaken:

- Collection of additional detailed geotechnical logging data from drill core and mapping of underground workings, to allow improved characterization of rock mass conditions within the immediate stope hangingwall zone, and the mineralized veins. This should incorporate collection of structural orientation data. Data collection should allow rock mass classification using an internationally recognized system, such as the Q-System (after Barton et al, 1974) or RMR (after Bieniawski, 1989).
- Development of a three-dimensional geological model with interpretations of primary lithologies and structures (such as faults and shear zones).
- Geotechnical investigations of any proposed shaft locations below -300 mRL to determine site suitability and ground support requirements. This should incorporate more detailed assessment of shaft pillar requirements.
- Geotechnical investigations of the surface crown pillar, particularly in the vicinity of the Hashui Creek valley, and any other streams or drainage paths that traverse the mine area.
- Further hydrogeological assessments, particularly to assess hydraulic connectivity between the Hashui Creek valley (and any other streams or drainage paths that traverse the mine area) and the underground mine workings.
- Further investigation of *in situ* stresses to confirm assumptions made in the mine design and stability assessments.

AMC now considers that, as part of ongoing operations at the mine, geotechnical and ground support aspects should be continuously reviewed in a formal and recordable manner, bearing in mind previous recommendations, local and mine-wide operating experience in all rock types encountered, any advisable data collection, and also looking to future mining development.

16.4 Extraction sequence

The global extraction sequence is top-down from +100 mRL extending down to -300 mRL and generally west to east for Stage 1 and Stage 2 above -50 mRL. It is centrally outwards from the Main Shaft location for Stage 2 below -100 mRL.

The macro stope extraction sequence is bottom-up for both stoping methods.

16.5 Production rate

Mine operations are conducted 365 days of the year but mine production is currently scheduled on the basis of 330 days per year at approximately 800 tpd for approximately 264 ktpa. An increase to a steady state rate from 2023 to 2027 of around 330 ktpa is planned. The remaining production life is estimated to be 12 years.

The average production is approximately 65 tonnes per day per stope for Shrinkage stopes and 15 tonnes per day per stope for Resue stopes with production per level capped at approximately 25% of the available stopes and up to 30 stopes concurrently working over all active levels.

The actual production rate from each stope is dependent on the vein width, and as such, the production rate and schedule assume a balance of wider and narrower vein stopes (generally Shrinkage and Resue respectively).

16.6 Mining methods

Shrinkage stoping and Resue stoping are the methods employed.

To support AMC's understanding of the Silvercorp application of stoping methods and also their suitability for the GC Mine environment, AMC previously observed the application of these stoping methods at Silvercorp's Ying mine operation during May 2016. The Ying mine is located in Luoning County, in the Henan Province, about 10 km South-East of Xiayu and about 60 km South-East of Luoning. AMC considers the methods employed to be appropriate for the GC Mine environment.

16.6.1 Shrinkage stoping

The method begins with establishing a sill drive along the vein to expose the vein at 2.4 m height. An access drive (conventionally a footwall drive) is also developed parallel to the vein at 2.4 m wide x 2.4 m high at a minimum stand-off distance of 6 m. Cross-cuts between the access and vein drives are developed at approximately 7.5 m strike spacing (actual spacing is dependent on the loader used, loader dimensions and the rib pillar thickness required for rib stability). The cross-cuts act as draw points for the mucking of the stope ore. Travelway raises that are also used for services are established between the levels at each end of the stope block. Waste packs are built on each void side of the raise as stoping proceeds upwards. Each stoping block is 50 m strike length by 50 m height.

Jackleg miners use pneumatic drills to drill a 1.8 – 2.0 m stope lift that is drilled and blasted as inclined up-holes with a forward inclination of 75 – 85° ("half-uppers"). The typical drill pattern uses a drill burden 0.6 – 0.8 m and spacing 0.8 – 1.2, depending on vein thickness. Holes are charged with cartridge explosives and ignited with tape fuse. The powder factor is expected to be 0.4 – 0.5 kg/t. Stope blasting fills the void below with ore as the mining proceeds upwards. While mining upwards, only 30 – 35% of the stope ore may be mucked until the entire stope is mined. At this point, all ore is mucked from the stope, leaving the stoping void effectively empty. A crown pillar is maintained for the stope to provide regional stability and to minimize dilution from up-dip stopes. Ventilation, compressed air and water are carried up the travel way raises to the stoping

level. Loading of the ore from the draw points is by rubber tired LHD into trucks (Stage 1) or electric rail over-throw loaders into rail cars (Stage 2).

Figure 16.4 depicts the Shrinkage stoping method as used at GC Mine.

Figure 16.4 Typical shrinkage stope layout

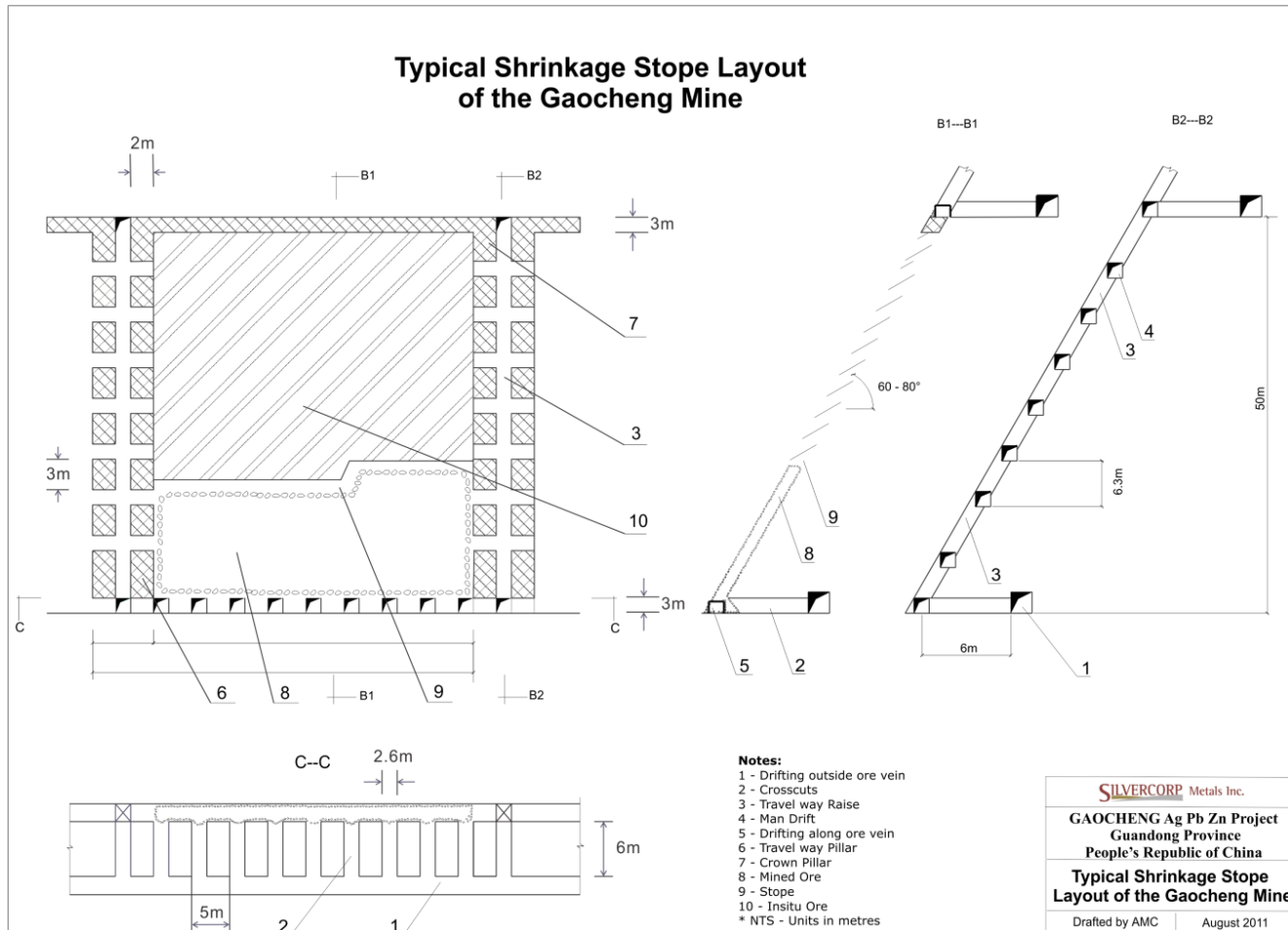

16.6.2 Resue stoping

Vein and access development preparation is essentially the same as for Shrinkage stoping except that an additional elevated sill drive (3 m on-dip height) is established along with draw points (generally limited to two) to provide access to the raise positions (raises equipped with steel liners as mill holes).

Resue stoping veins are typically higher-grade and generally between 0.20 m (minimum extraction width 0.3 m) and 0.80 m width. Resue stoping involves separately blasting and mucking the high grade narrow vein and waste required to achieve a minimum stoping work width.

The mining crew consists of Jackleg miners using pneumatic drills. Half-upper lifts are drilled and blasted in essentially the same manner as for Shrinkage stoping. After an ore lift is blasted and mucked, the footwall is blasted and used to fill the space mined out. This process is repeated until the crown pillar is reached. The entire stope is left filled with waste from the slashing of the footwall.

The blasted ore is transported by wheel barrow and / or hand shovelling to the steel lined mill-hole. The steel pass is constructed in lift segments as the stope is mined upwards. The base of the steel pass is held in place with a timber set. The footwall waste is then slashed (blasted) to maintain a minimum mining width (typically 0.8 m for GC) and to provide the working platform for the next stope lift. In contrast to Shrinkage stoping, the mined out stope is left filled with waste from the slashing of the footwall necessary to maintain a minimum mining thickness and to provide a working platform.

The order of vein extraction and footwall slashing is generally dependent on the condition of the vein hangingwall contact. Where the vein hangingwall contact is distinct and stable, the vein is extracted first; otherwise the footwall waste is extracted first followed by vein slashing.

Rubber mats and / or belting are placed on top of the levelled waste after each waste lift to minimize ore intermingling with the waste (ore losses) and also to minimize over-mucking of the waste (dilution). Mucking of the ore consists of hand lashing (shovelling) and hand carting to the steel pass which connects to the mill hole crosscut. The rubber mats and / or belt are rolled up and removed for reuse prior to slashing the footwall and forming the next platform lift.

In-stope ore transporting may potentially be improved by using scraper winches with small hoes.

Figure 16.5 depicts the Resue stoping method as proposed at GC Mine.

Figure 16.5 Typical resue stope layout

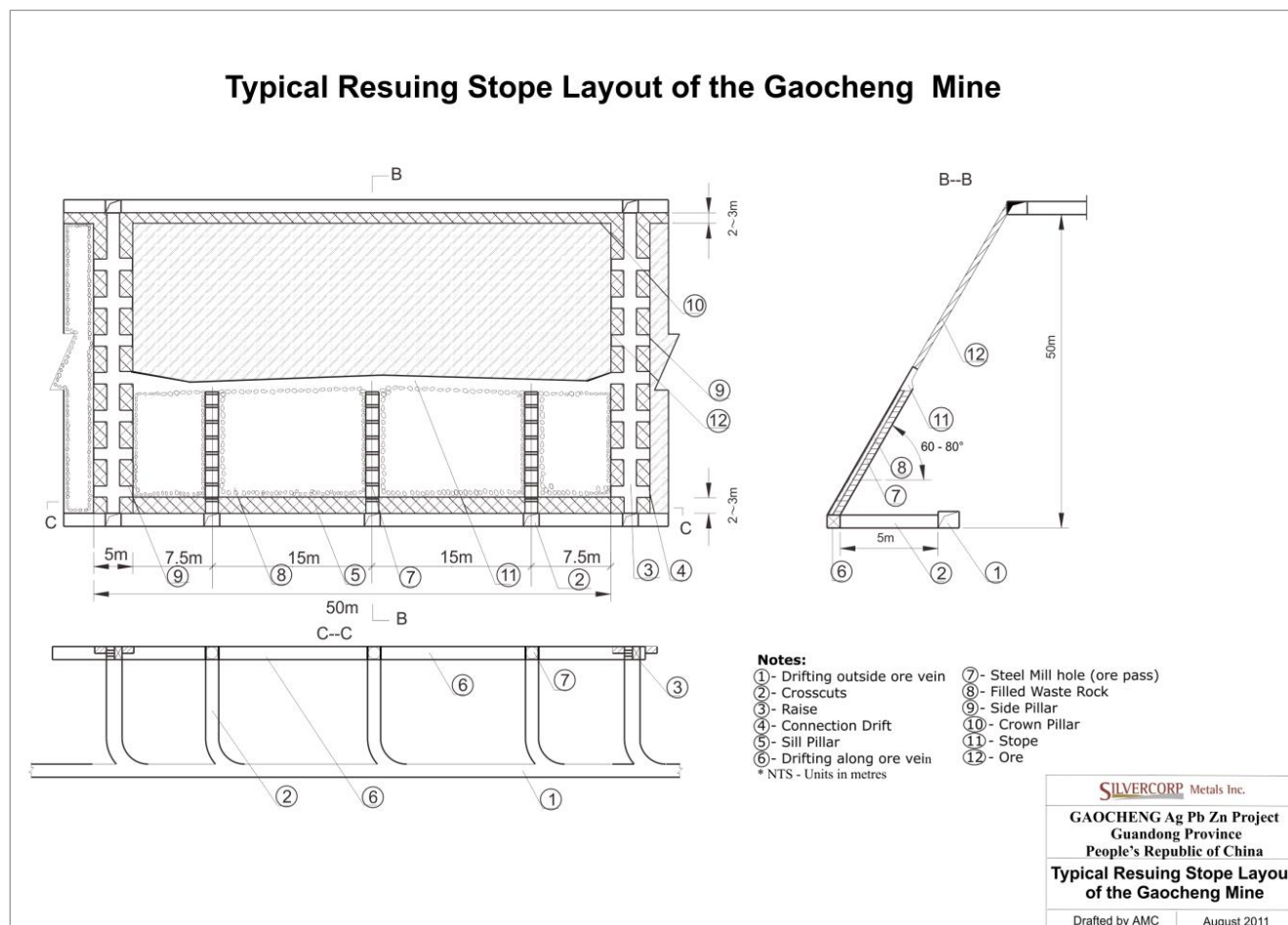

16.6.3 Resue management and grade control

Silvercorp has developed a stope management protocol and stope management manual at the GC and Ying operations. The purpose of stope management is to implement stope operation procedures for dilution reduction via the Mining Quality Control Department. The department has a total of four technical staff, including management, mine engineer, geologist, and technician. The mine engineer in the group is responsible for supervising the stope operation procedure, with stope inspection occurring at least once per day to check that mine contractors are following procedure guidelines. The geologist and geological technician are responsible for stope geological mapping and sampling, which occurs every 1.5 m of stope lift. The department also measures the mined area of a stope at the end of each month for mine contract payment and reconciliation purposes.

Key aspects of the stope inspection are as follows:

- Ensuring that the back and floor of the stope are flat prior to drilling blasting holes.
- Checking to ensure the boundary of the mineralization and drillhole locations are correctly marked with red paint before drilling.
- Ensuring drillholes are inclined not less than 60° to the horizontal, are not longer than 2 m, and are drilled optimally relative to vein and excavation width to minimize dilution.
- In a resuing stope, checking if the stope floor is covered with rubber mat / belt before blasting.
- In a resuing stope, checking to make sure that waste is sorted first and left in the stope before mucking ore to the mill holes after blasting; also ensuring that the floor and walls are cleaned with a broom to minimize ore losses before footwall slashing.
- After blasting, checking that the stope back is not more than 3.5 m high and the steel mill holes in a resue stope are properly covered with steel grid.

Regarding contract payments, a mine contractor is paid based on the amount of ore mined. As it may be seen as an incentive for the contractor to maximize material removed from the stope, contractor payments are governed by a specific formula that calculates planned ore tonnes based on extraction to design and a planned dilution factor. During mine operations, each rail car or small tricycle load of ore is weighed at a weigh station outside the mine portals. If weighed ore tonnes are greater than planned ore tonnes from a given stoping area, the mine contractor is paid solely based on the planned tonnes. For shrinkage stopes, an adjustment for paid tonnes is required to be made, since a stope usually takes several months to complete and, generally, only blast swell is mucked until the stope nears completion.

16.7 Mine design

The mine design is based on the engineering work completed by the local official provincial design institute GMADI (April 2016). Refinements in areas such as profile dimensions, alignments, fleet sizing, etc. have been made by Silvercorp technical personnel on an as-needed basis during the project construction and operations phases.

The initial mine design provided prior to the commencement of operations was considered by AMC to be below feasibility study standard (within +/- 10 – 15% on the inputs) with respect to knowledge of the vein location and vein peripheral extents and missing minor miscellaneous development items such as travelway refuges, stripping and service holes. Design aspects have been progressively advanced and refined as operations have progressed but without any major change in development requirements.

In plan view, the mine development covers an area approximately 600 m by 1,200 m between Mine Sections 8 and 56. The mine design total lateral and vertical requirements are projected at

116,526 m and 35,220 m respectively. A surface plan, showing key mine infrastructure locations is provided in Figure 18.1.

Figure 16.6 illustrates the mine design for stopes and development drives looking generally north-west.

Figure 16.6 GC Mine design

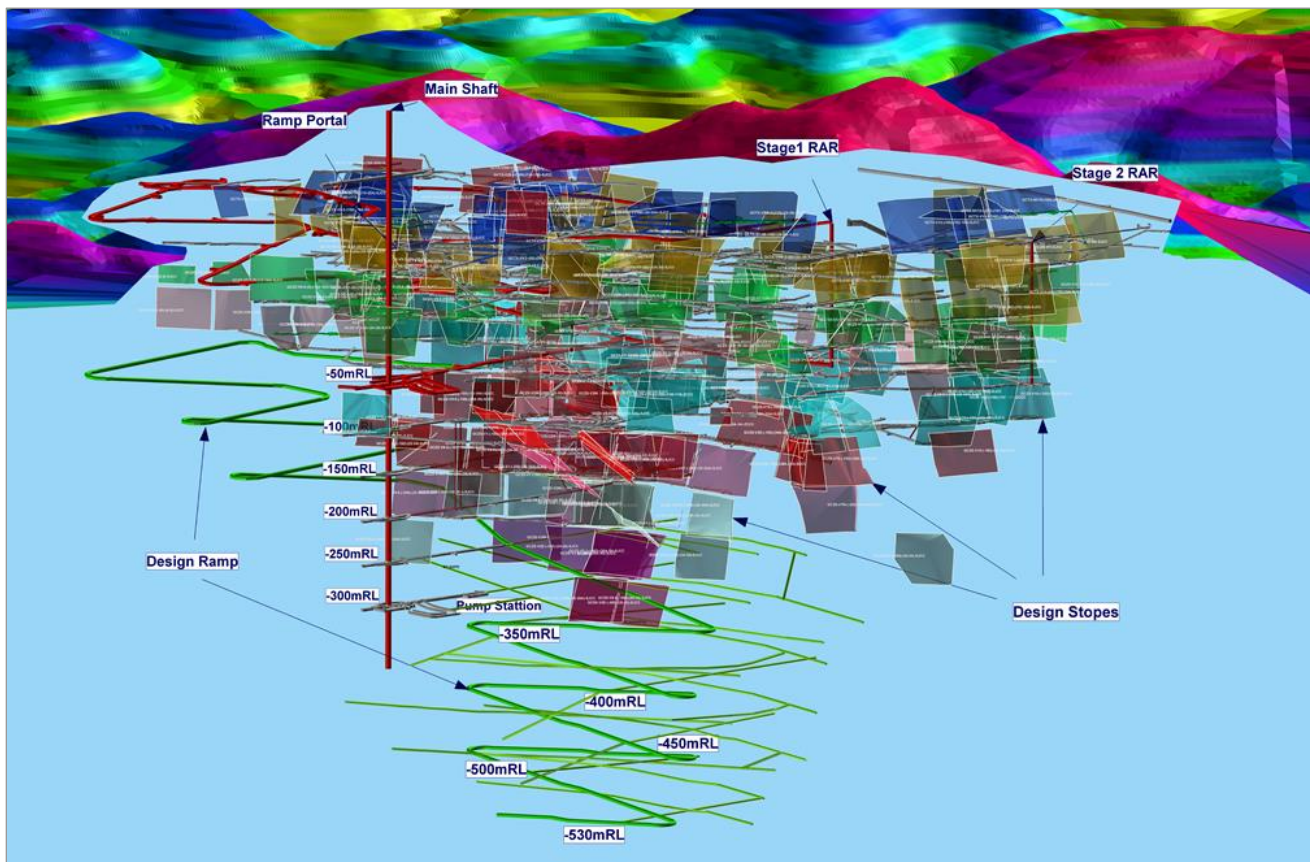

The design strategy has been effectively two-staged, with Stage 1 being predominantly mechanized development to fast track production while the longer term Stage 2 at deeper levels reverted to Chinese conventional tracked development methods. Both stages of construction are completed and approved by local government departments.

The Stage 1 Ramp is used for hauling ore, waste rock, materials, equipment, personnel, and providing access for key services like dewatering lines, feed water, power, communications, and ventilation.

The Stage 2 Main Shaft is used for cage hoisting ore and waste, hoisting materials, equipment, personnel and providing access for key services like dewatering lines, feed water, power, compressed air, communications, egress ladderways and ventilation.

Figure 16.6 is noted to also illustrate the mine design stages, with the development driveage in red indicating Stage 1 development and that in bright green indicating Stage 2 development.

The veins included in the mine design are NV10, NV28-1, V1, V10, V10-1, V10-3, V10-4, V11, V12, V13, V14, V16, V17, V18, V19, V2-1, V2-2, V2-3, V24, V2-4, V25, V26, V28, V28-4, V28-4-1, V29, V2E, V2E1, V2E4-4, V2W, V2W-0, V2W-4, V2W-5, V2W-6, V30, V32, V33, V36, V40, V43, V45, V5, V5-1, V5-3, V5-5, V5-6, V6, V6-0, V6-1, V6M, V6M-2, V7, V7-1, V7-1E, V7-3, V7E, V7N, V8, V9-1, V9-3, V9-5, V9W-2, V9W-2E, and VH1-1.

Figure 16.7 is indicative of relative vein positions and development design at -150 mRL.

Figure 16.7 GC veins and development plan at - 150 mRL

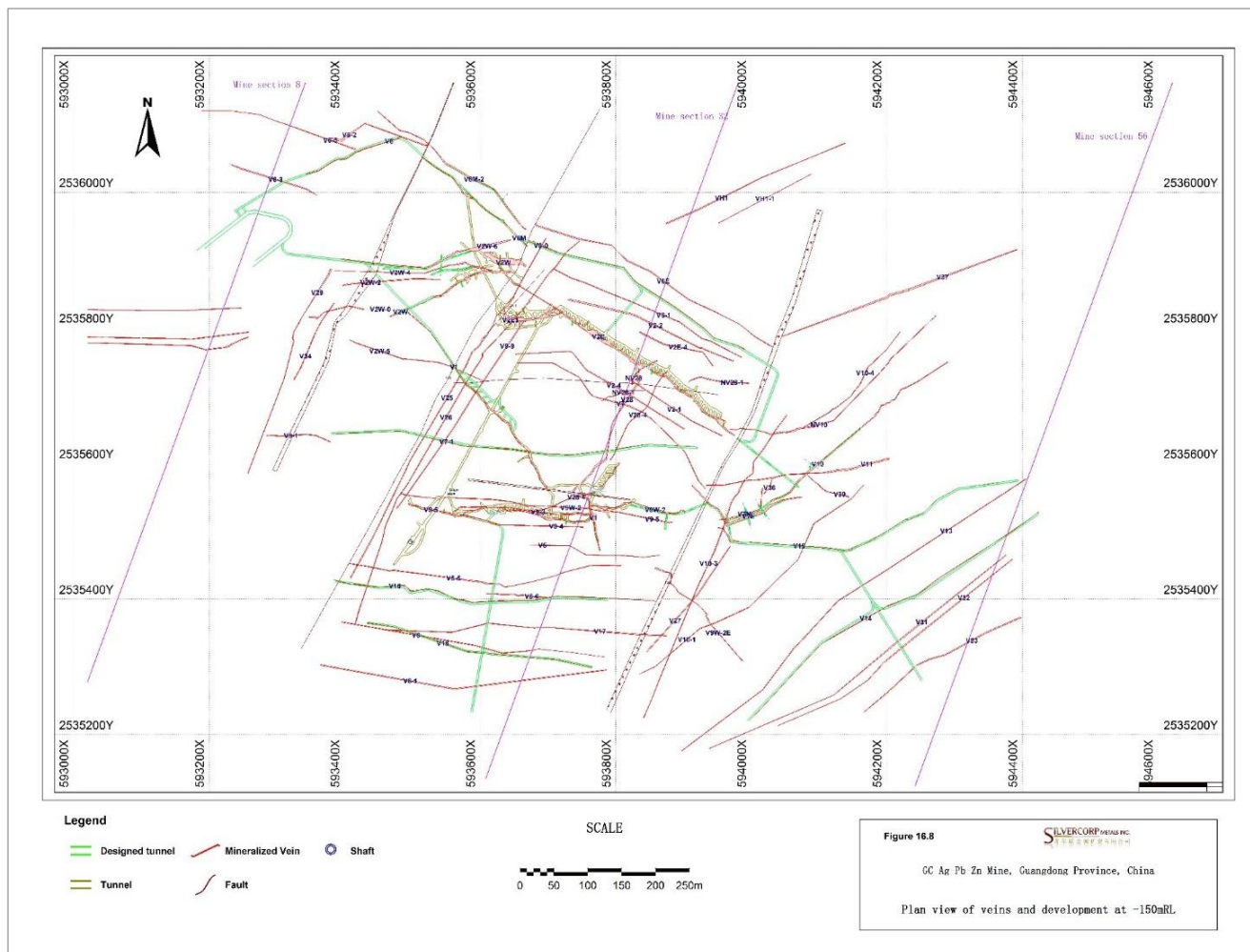

16.7.1 Pre-existing development

In the current mine design there is some minor pre-existing development off three adits, named ML5, ML6, and ML8. The ML6 adit is located at the immediate west side of the Gaocheng Village. The development from the three adits has a combined void volume of approximately 13,000 m³ (as advised by the GMADI study). Table 16.2 summarizes the complete list of pre-existing development in the GC project resource area, along with coordinates for the Main Shaft and the Stages 1 and 2 RARs.

The pre-existing ML6 and ML8 development has been used, as appropriate, in the mine design (e.g. ventilation and egress purpose). The ML6 adit is used as a ventilation airway (intake initially reverting to exhaust) and environmental precautions have been referenced in protecting the

amenities of the Gaocheng Village. ML6 and ML5 were used in the past for sampling to validate some of the vein resource estimates (V2 and V10 respectively).

Precautions have also been undertaken to prevent the pre-existing development becoming water logged or exposed to surface run-off inundation to eliminate the possibility of mud or water in-rush in the un-likely event of subsidence from the stoping areas immediately below. This is partially ameliorated by the Hashui Creek diversion tunnel.

Table 16.2 Co-ordinates of pre-existing development, Main Shaft, and RARs

Adit	Northing	Easting	Elevation
ML1	2,536,522	37,593,270	139
ML2	2,536,898	35,793,310	97
ML3	2,536,444	37,593,459	129
ML4	2,536,759	37,592,679	120
ML5	2,535,758	37,594,035	116
ML6	2,536,156	37,593,460	101
ML7	2,536,450	37,593,241	148
ML8	2,535,761	37,594,440	117
ML9	2,536,375	37,593,315	110
Ramp	2,535,330	37,593,581	176
Main Shaft	2,535,544	37,593,562	248
Stage1 RAR	2,535,692	37,593,954	120
Stage2 RAR	2,535,586	37,594,206	122

16.7.2 Mine access

As indicated above, mine access for rock transport, materials supply and labour access is provided by a decline (Ramp) and a shaft (Main Shaft). Secondary mine access for labour emergency egress is provided by the Ramp Shaft, Stage 1 and Stage 2 return airway shafts, and the +100 mRL level connections from the ML6 and ML8 adits.

The initial ramp alignment is approximately parallel with the local grid Line 10 at the western end of the project area. The ramp portal co-ordinate is at approximately 37,593,581 m east, 2,535,330 m north, +176 mRL elevation. The ramp provides access to the +100 mRL, +50 mRL, 0 mRL, -50 mRL and -100 mRL levels. The ramp spirals to the bottom located at -64 mRL. The ramp profile is 4.2 m wide by 3.6 m high (approximately 13.9 m² profile area). The average gradient is 12% (1 in 8.3) with minimum radius of 20 m. The total ramp access length is 2,224 m (excluding stockpiles).

The ramp includes 10 m length remuck stockpiles at approximately 100 m intervals with travelway refuges excavated between the remuck stockpiles. The ramp spirals at the northern end to make connections to a blind sunk shaft (Ramp Shaft) at approximately +100 mRL, 0 mRL, -50 mRL, and -100 mRL. The Ramp Shaft at 3.5 m diameter (9.6 m²) was designed to act as a return ventilation airway during ramp development and revert to an intake ventilation airway prior to Stage 1 production. The Ramp Shaft also provides secondary egress and is used for mine services (piping for air and water, electrical cables and ladders).

The Main Shaft collar is located at +248 mRL elevation at approximately 37,593,562 m east, 2,535,544 m north. The shaft diameter is 6.0 m.

16.8 Mine development

The mine design is now based on Mineral Resources above 100 g/t AgEq, with the addition of vein exploration development (which in some part, is also used for stope access). Vein exploration development is categorized as development that occurs outside of the mineral resource categorization. Vein exploration development is reported as development waste and, for planning purposes, is assigned zero grade irrespective of its actual resource grade.

The mine levels are located at 50 m vertical intervals. Levels are graded at 0.3% from either the Ramp or Main Shaft access, however the mine design provided does not incorporate this feature. AMC does not consider this to be material with respect to estimates for development quantities.

Thus far, Phase 1 and Phase 2 development has all been completed. The production and ventilation systems consist of Main Shaft, Main Ramp, Exploration Ramp, and Phase 1 and 2 ventilation shafts.

The Main Shaft (from +248 mRL to -370 mRL) is used for hoisting of ore, waste rock, equipment and materials, personnel, and for intake airflow for -100 RL and below levels.

The Main Ramp (portal elevation +176 mRL, bottom elevation -67 mRL) is used for transportation of ore, waste rock, equipment and materials, personnel, and for intake airflow for -500 mRL and above levels.

The Exploration Ramp is used for transportation of ore, waste rock, equipment and materials, personnel, and for intake airflow for +100 RL and +50 mRL levels.

At present, GC mine is extending the Main Ramp from -50 mRL to -300 mRL. There is a plan to extend the main ramp to -530 mRL for transportation of ore, waste rock, equipment and materials, personnel, and for intake airflow for -300 RL level and below.

16.8.1 Development requirement

Table 16.3 summarizes the vertical development requirement, profiles, and categories.

Table 16.3 Vertical development profiles and categories

Year	Capital Lateral (m)	Capital Vertical (m)	Operating Lateral (m)	Operating Vertical (m)	Total (m)
FY2018Q4	-	50	824	540	1,414
FY2019	1,515	50	14,810	3,240	19,615
FY2020	2,720	-	12,535	5,670	20,925
FY2021	2,200	-	10,636	2,610	15,446
FY2022	1,840	150	7,928	4,560	14,478
FY2023	1,365	150	10,269	2,010	13,794
FY2024	985	150	9,350	2,970	13,455
FY2025	1,655	550	9,331	3,120	14,656
FY2026	1,420	-	8,246	3,660	13,326
FY2027	200	-	7,308	1,560	9,068
FY2028	-	100	6,483	2,640	9,223
FY2029	-	200	4,164	1,080	5,444
FY2030	-	160	742	-	902
Total	13,900	1,560	102,626	33,660	151,746

Table 16.4 summarizes the development waste volumes projected.

Table 16.4 Development waste

Year	Waste (m ³)
FY2018Q4	5,685
FY2019	97,693
FY2020	107,804
FY2021	82,349
FY2022	70,997
FY2023	66,005
FY2024	60,234
FY2025	70,268
FY2026	59,762
FY2027	39,735
FY2028	36,965
FY2029	23,822
FY2030	4,877
Total	726,195

Figure 16.8 shows projected development metres by type over the LOM.

Figure 16.8 Development profile by type

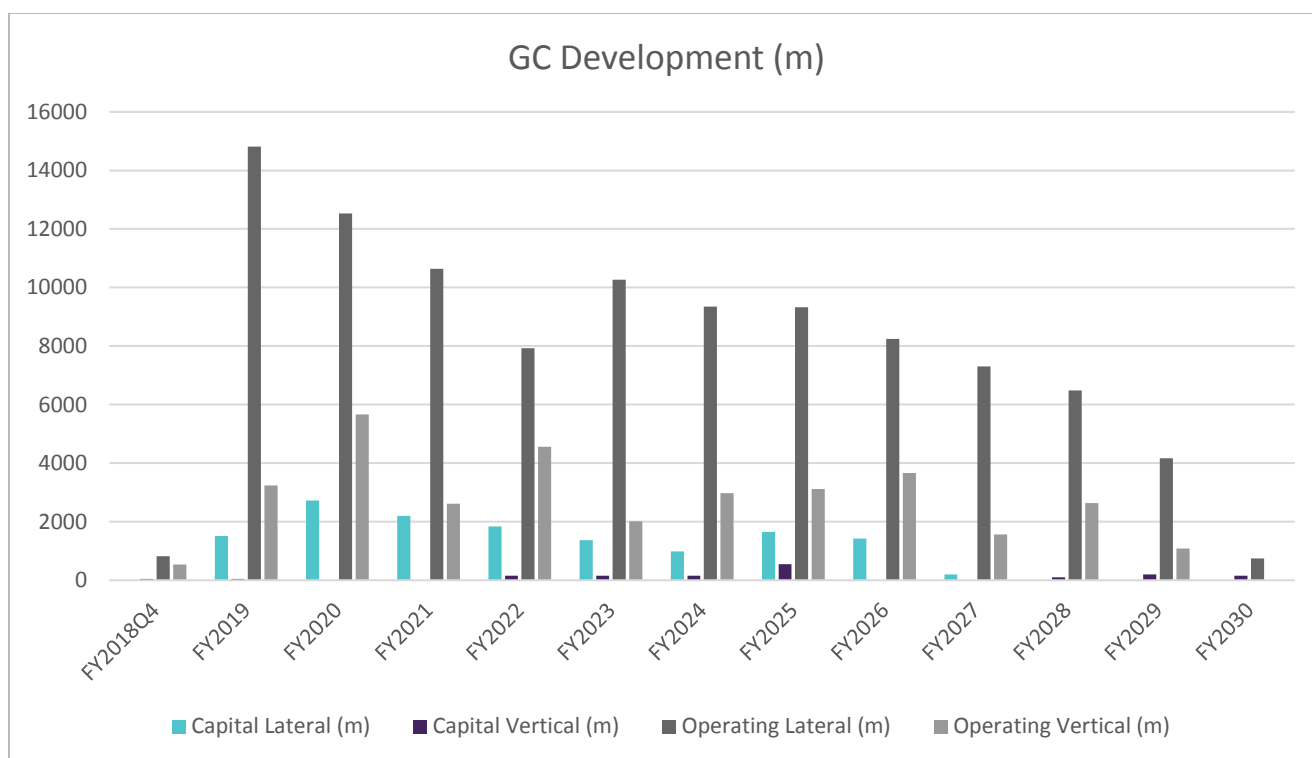

16.8.2 Shafts

Several shafts have been planned for the LOM design. All shafts have been planned to be sunk by conventional underhand method.

Table 16.5 summarizes the general details for each shaft.

Table 16.5 Mine shafts

Shaft name	Diameter (m)	Collar elevation (mRL)	Bottom elevation (mRL)	Depth (m)	Profile	East collar co-ordinate	North collar co-ordinate	Collar access
Ramp extend	4.2 x 3.75	176	-530	706	Rectangular	37,593,581	2,535,330	Surface
Stage 1 Ventilation Raise	3.5	120	-50	170	Circular	37,593,954	2,535,692	Surface
Stage 2 Ventilation Raise	3.5	122	-50	172	Circular	37,594,206	2,535,586	Adit
Main Shaft	6	248	-370	618	Circular	37,593,562	2,535,544	Surface
Main Shaft Sump Access	4.17 x 3.4	-300	-305	5	Rectangular	37,593,567	2,535,575	Internal

16.9 Mine production

16.9.1 Commercial production to end-2017

Table 16.6 shows reported GC production from start of commercial operations in FY2015 (Q2 2014) to end of December 2017.

Table 16.6 GC production FY2015 – FY2018

Fiscal year	FY2015	FY2016	FY2017	FY2018 (Q2 to Q4 2017)	Totals
Ore mined (tonnes)	253,321	257,575	260,746	216,342	987,984
Head grades					
Silver (g/t)	107	94	94	99	98
Lead (%)	1.35	1.76	1.44	1.50	1.51
Zinc (%)	2.65	2.53	2.81	2.80	2.69
S grade, %	9.29	9.19	10.55	9.94	9.74

16.9.2 LOM plan production

Projected LOM production is the combination of development ore and stope ore and is summarized in Table 16.7.

Table 16.7 LOM production summary

Quarter / F-year	Ore tonnes	Mined ore grade				Planned metals		
		AgEq	Ag (g/t)	Pb (%)	Zn (%)	Ag (t)	Pb (t)	Zn (t)
FY2018Q4	30,632	298	96	1.15	3.46	2.94	352	1,059
FY2018-total	30,632	298	96	1.15	3.46	3	352	1059
FY2019Q1	59,940	296	96	1.31	3.26	5.76	783	1,953
FY2019Q2	64,444	300	96	1.22	3.44	6.19	785	2,214
FY2019Q3	71,445	298	104	1.36	3.06	7.44	971	2,185
FY2019Q4	47,288	322	136	1.42	2.82	6.42	672	1,333
FY2019-total*	243,118	303	106	1.32	3.16	26	3210	7686
FY2020Q1	68,007	320	105	1.56	3.32	7.17	1,063	2,258
FY2020Q2	65,856	346	110	2.06	3.30	7.26	1,358	2,171
FY2020Q3	85,508	348	113	1.91	3.46	9.64	1,632	2,960
FY2020Q4	63,420	339	139	1.61	2.95	8.80	1,021	1,873
FY2020-total	282,790	339	116	1.79	3.28	33	5073	9262
FY2021	294,124	351	132	1.65	3.36	38.77	4,850	9,873
FY2022	314,030	335	110	1.90	3.23	34.50	5,960	10,157
FY2023	329,479	321	102	1.57	3.41	33.70	5,166	11,234
FY2024	332,924	317	104	1.57	3.30	34.51	5,227	10,975
FY2025	335,778	303	95	1.62	3.12	31.87	5,441	10,475
FY2026	321,470	289	107	1.26	2.89	34.45	4,058	9,298
FY2027	323,713	255	79	1.12	2.88	25.60	3,628	9,338
FY2028	299,861	247	75	1.10	2.81	22.59	3,300	8,425
FY2029	251,114	208	56	1.00	2.47	14.09	2,503	6,204
FY2030	204,791	206	58	0.96	2.42	11.84	1,963	4,952
Total	3,563,826	293	96	1.42	3.06	344	50,732	108,938

Note: Excludes 6,882 t of exploration tunneling material anticipated to be ore in 2019 budgeting.

The life-of-mine (LOM) production duration is planned for 12 years with currently defined Mineral Resources. The average production rate will be 300 ktpa of ore from 2019 to 2030 inclusive. A steady state mine production rate of approximately 330 ktpa is projected from 2023 to 2027 inclusive. Figure 16.9 summarizes the LOM production profile for the development and stope ore.

Figure 16.9 LOM production profile by type

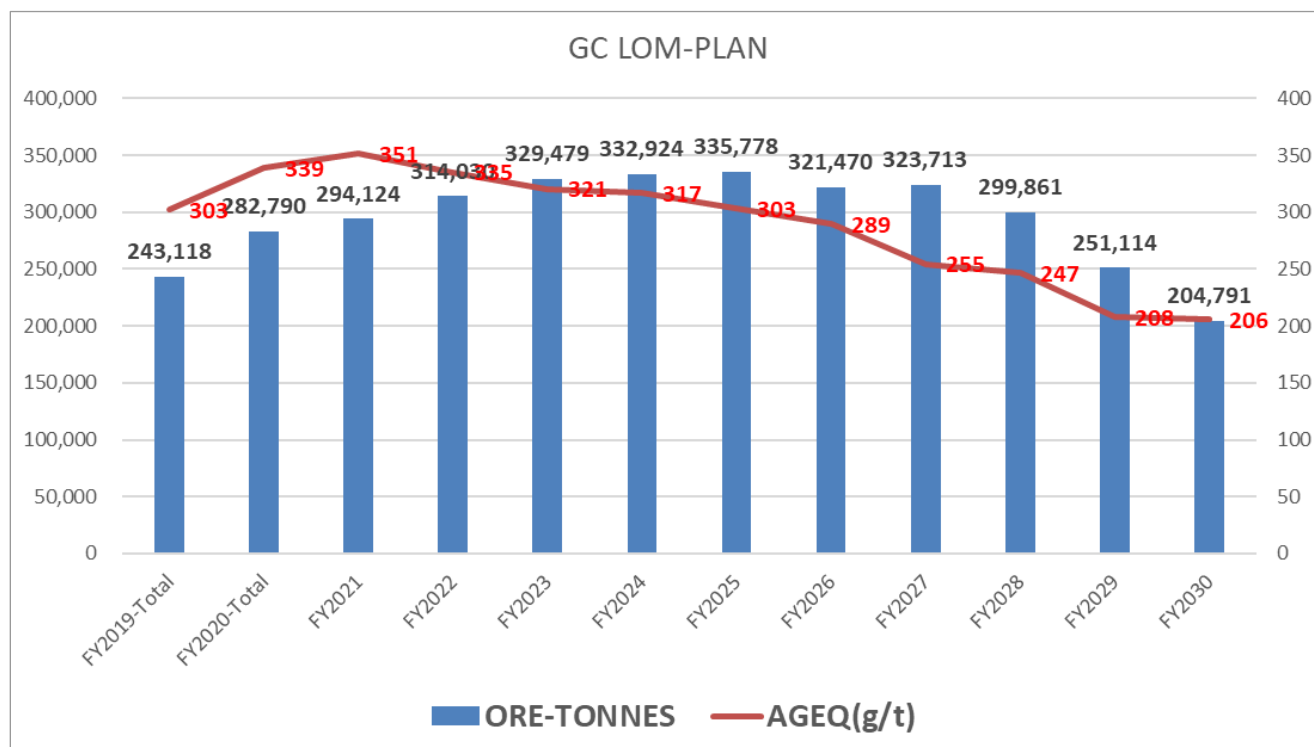

16.10 Rock handling

Total ore and waste quantities planned to be produced over the LOM are approximately 3.56 Mt and 1.96 Mt respectively.

All waste in the mine plan is currently disposed of at surface, either by Silvercorp for any mine construction needs or by local area persons who collect it free of charge for construction material.

Hand sorting of waste from ore at surface is conducted opportunistically.

16.10.1 Shaft hoisting

The shaft has one tower-mounted multi-rope friction winder (600 kW), and is used for hoisting of waste, labour, materials, and mine equipment access for areas below the -50 mRL. The shaft is also used for intake air, services access (ladder, cables, and pipes) and labour emergency egress.

The shaft hoisting capacity is estimated to be approximately 800 ktpa ore and 400 ktpa waste. The capacities are estimated based on 330 days per year, 3 shifts per day, and 8 hr shifts.

Waste that is cage hoisted in rail cars to surface is transferred to the rail waste dump tip head that is within 200 m of the Main Shaft.

Figure 16.10 shows the Main Shaft headframe.

Figure 16.10 Main Shaft headframe



16.10.2 Waste material

The total LOM waste produced is projected to be 1.96 Mt.

Other than use for construction purposes as indicated above, waste could opportunistically be disposed of into the Shrinkage stope voids (with approximately 1.2 Mm³ or 2.3 Mt void capacity), but this is not in the current mine plan. The potential for waste disposal into Shrinkage stope voids represents 100% of the LOM waste produced.

16.11 Mine services

The mine services are described in the following sub sections.

16.11.1 Ventilation

Mine ventilation is practiced as set out by Chinese laws and regulations. Among key ventilation regulations are; minimum ventilation volume per person (4 m³/min/person), minimum ventilation velocity (typically 0.25 – 0.50 m/sec dependent on location or activity) and minimum diluting volume for diesel emissions (4 m³/min/kW).

The primary ventilation generally flows from west to east using the main levels interconnected by dedicated level vent raises (plus active stope accesses). The upper level(s) where stoping has been completed are used as return airways to separate the fresh and exhaust air. A series of air doors and sealed walls is utilized in the ventilation system. Inactive development headings and draw points are sealed to enhance the ventilation circuit by minimizing leakage.

16.11.1.1 Primary ventilation

The ventilation volume is predominantly influenced by the minimum air velocity for the various development and production activities. No diesel equipment is required for Stage 2 mining. The peak ventilation volume is estimated to be 140 m³/sec inclusive of 30% air leakage. The total air quantity is 105 m³/sec, with 25 m³/sec from the decline and 80 m³/sec from the shaft. The primary fan (Dk-12-No.32) is powered by YB630S-12 electrical motors (250 kW x 2, one for standby).

The fresh air intake airways are:

- Main Shaft (6.0 m diameter located approximately at Mine Section 22) with air flow of 80 m³/sec at the collar. Friction factor acknowledges hoisting furniture in the shaft. For hoisting intake airways, there is a regulatory requirement for air purification prior to a level receiving fresh air from the Main Shaft.
- Ramp (4.2 m x 3.6 m located approximately at Mine Section 26) with 25 m³/sec at the portal.
- Ramp Shaft (3.5 m diameter located at Mine Section 10) with 33 m³/sec at the collar.

The return air exhaust airways are:

- Stage 2 Ventilation Shaft (3.5 m diameter located approximately at Mine Section 52). The fan duty point is 140 m³/sec at 2070 Pa (total pressure). The friction factor assumes the shaft is furnished with a ladder way. The exhaust fan configuration is axial (200 kW – 380 V) mounted horizontally with a fan diffuser for silencing. The development on the inlet side is configured to enable emergency egress. The Stage 2 Ventilation Shaft is developed internally within the short adit with the fan installation also established within the adit drift development.

The key airway regulation requirements are:

- Vehicle access doors (airlock system) placed in the Ramp level accesses for the +100 mRL, +50 mRL and 0 mRL levels.
- Two regulators on the -100 mRL level and one on the -50 mRL level to force air to the lower level working areas.
- The Stage 1 Vent Shaft is sealed at the collar and is used as an internal exhaust.
- All rock passes are assumed to be filled with rock for leakage purposes.
- All stope and inter-level ventilation raises include ladderway resistances.

16.11.1.2 Secondary ventilation

The secondary ventilation consists of auxiliary fans for ventilating development faces, infrastructure chambers, loading and tipping areas and stope faces.

Development faces are ventilated using domestically manufactured fans (5.5 kW – 380 V). A combination of forced and exhaust ventilation will be applied for long blind-heading distances as required.

Stopes are force ventilated using domestically manufactured fans (4 kW – 380 V) via the access timber cribbed travel way. The stope air returns to the upper level via a second access travel way at 50 m strike spacing.

16.11.2 Water supply

The source of water for the mine is from local creeks and gullies that flow into the Hashui Creek. The flows typically vary from about 11,000 m³/day (dry season) to 69,000 m³/day (wet season) with the wet season being from April to September inclusive. The annual average rainfall varies in the range of 1,400 – 1,734 mm. The water quality and quantity from the local creeks is sufficient to meet the project requirements, which are of the order of 2,000 m³/day.

Water is drawn from the Bai Mai reservoir (at approximately Mine Section 56 and elevation 105 mRL) and pumped to an elevated hill top (at approximately 343 mRL) for water treatment-filtration and surge capacity storage. The treated water is then gravity fed to the mine site and treatment plant (at approximately 248 mRL).

The key specifications of the water supply system are:

- Bai Mai reservoir water tank with 100 m³ of settle capacity and 200 m³ clean water capacity.
- Hill top water tank with 300 m³ storage, and water filtration capability via two filtration units.

Water consumption underground is primarily for drilling and suppressing dust.

Potable water is provided underground adjacent to the Main Shaft with water quality conforming to regulatory requirements. Personnel carry drinking water as required to remote work place in water containers.

16.11.3 Dewatering

Underground water is discharged to surface using conventional centrifugal pumps via pipe lines installed in the Ramp, Ramp Shaft, and Main Shaft. Underground water pumped to surface is collected in ponds at the Ramp portal or Main Shaft for sediment settling prior to being pumped to the process plant water treatment station. The underground water is discharged to surface in two stages in relay.

At the Stage 1 pump station (-300 mRL), three pumps (Model MD155-67×5, capacity 155 m³/h) are installed. Water from -300 mRL pump station is discharged through two steel pipelines installed in the shaft to the Stage 2 station.

At the Stage 2 pump station (-50 mRL), three pumps (Model MD280-43×8, capacity 280 m³/h) are installed. Water from -50 mRL pump station is discharged through two steel pipelines installed in the Ramp to the surface.

As indicated, three pumps are installed in each pump chamber. Under normal water inflow conditions one unit is running, one unit is under maintenance, and the other is on standby. Under

maximum water inflow conditions, two pumps will be running. Underground pumps are specified for clean water discharge, so each pump station has its own twin compartment sediment settling arrangement. The capacity of these is equivalent to six to eight hours of normal water inflow condition (Safety Regulations on Metal and Nonmetal Mining Operation – National Standard GB16423-2006).

Quality monitoring of the mine water and the surrounding receiving surface water is conducted on a regular basis.

In 2017, a total volume of 468,630 m³ of underground water was treated, including 268,844 m³ discharged and 199,786 m³ recycled. The water treatment cost for year 2017 was US\$0.0371/m³. Table 16.8 shows underground water pumped, discharged, and recycled by month for year 2017.

Table 16.8 Underground water pumped, discharged, and recycled for year 2017

	U/G water pumped m ³	Discharged m ³	Recycled m ³	Recycle rate %
Jan 2017	28,644	23,226	5,418	18.90%
Feb 2017	30,084	22,980	7,104	23.60%
Mar 2017	35,960	22,922	13,038	36.30%
Apr 2017	31,786	11,752	20,034	63.00%
May 2017	38,386	18,311	20,075	52.30%
Jun 2017	39,309	23,668	15,641	39.80%
Jul 2017	42,416	23,491	18,925	44.60%
Aug 2017	43,659	22,839	20,820	47.70%
Sep 2017	49,809	27,005	22,804	45.80%
Oct 2017	44,248	28,410	15,838	35.80%
Nov 2017	41,068	24,219	16,849	41.00%
Dec 2017	43,261	20,021	23,240	53.70%
Total	468,630	268,844	199,786	42.60%

Pumping demand under normal conditions is approximately 5.5 hours per day and, under maximum conditions, would be approximately 10 hours per day. Pump station sumps provide six hours of water inflow capacity.

For secondary dewatering, conventional compressed air diaphragm and / or electric submersible pumps are used for face dewatering on an as-needed basis. Water is stage discharged via a pump line to the surface settling pond or the -50 mRL pump station.

Levels are self-draining (0.3% gradient) to either the Ramp access or Main Shaft access drainage holes. Drains are constructed from 245 mm diameter half pipes.

16.11.4 Power supply

Power is provided from a 110 kV substation near Gaocun town, about 6 km from the mine site, which is fed from the Guangdong Province electrical grid system.

High voltage supply is 10 kV to the surface sub-stations. The mine has standby diesel generator power for essential mine facilities (pump stations, shaft operations, primary ventilation fans).

Underground sub-stations are located on each level. Level development utilizing Jumbo development has incorporated additional sub-stations along the level to manage voltage drop from the sub-station.

Low voltage supply from the underground sub-stations is 415 V (Jumbo), 380 V (pumps and fans), and 220 – 250 V (lighting and rail operation).

There are two 1,500 kW diesel power generator on standby.

16.11.5 Fuel storage and dispensing

No fuel is stored underground. Trucks and loaders are re-fueled at the surface fuel farm and dispensing facility.

16.11.6 Compressed air

Compressed air is primarily used for drilling blastholes. Jackleg drilling is used in the stopes and conventional development faces. There is some minor use for shotcreting, blasthole cleaning, and ANFO charging of blastholes as necessary.

Compressed air is reticulated to all levels and to the emergency refuge stations.

Compressors (electrically powered two-stage piston compressors) are located adjacent to the Ramp portal (2 x 20 m³/min, 0.8 Mpa, 110 kW) and Main Shaft brace area (2 x 40 m³/min, 0.8 Mpa, 250 kW). Compressed air is reticulated using steel and plastic piping for air distribution via the Main Shaft (via the Ramp and Ramp Shaft for earlier Stage 1 operations).

16.11.7 Communications

Mine surface communications are available by landline and mobile phone services.

Telephones are the base means of communicating with underground. Phones are located adjacent to the Ramp level accesses (Stage 1 set-up) and adjacent to the Main Shaft level accesses.

16.11.8 Explosives storage

The surface explosives magazine is permitted to hold 10 t of bulk explosives and 15,000 detonators. Security services are used, and detonators are scanned on release from the magazine for security audit purposes.

Underground working party magazines are located adjacent to each level return air shaft and are limited to one day of requirement for bulk explosives and three days of requirements for blasting ancillaries.

16.11.9 Mine equipment maintenance

The mining contractor has its own mobile equipment workshop for repairs and servicing located adjacent to the Ramp portal. There are also underground drill service bays established in redundant stockpile areas to minimize tramming delays.

Mobile equipment repairs (trucks, loaders, etc.), other equipment breakdowns and equipment major services are conducted in the mining contractor's surface workshop with minor services conducted in redundant stockpile areas.

Minor equipment (such as jacklegs, secondary fans, development pumps, etc.) are also serviced in the mining contractor's surface workshop.

The electric locomotive and rail cars are serviced and repaired in a service rail sidings located adjacent to the Main Shaft.

Other fixed and mobile plant (primary pumps, surface electric locomotive, rail cars, vehicles, etc.) are serviced in Silvercorp's surface workshop located adjacent to the Main Shaft. This is fully equipped with overhead crane, welding, electrical, hydraulic, lathe services, etc.

16.12 Mine equipment details

All mobile equipment and some minor fixed plant is provided by the mining contractor.

The Silvercorp fixed plant is predominantly domestically manufactured and locally sourced (Guangdong Province). The equipment manufacturers are well known and commonly used for China mine operations.

Table 16.9 summarizes the typical type and capacity of the contractor equipment.

Table 16.9 Mining contractor typical key equipment summary

Contractor equipment	Stage	Units	Manufacturer	Model	Capacity
Single Boom Jumbo	1	2	Atlas Copco	Boomer 281	3,660 mm rod
LHD small	1	2	Anhui Tongguan Machinery Co. Ltd.	TCY-2A	2 m ³
LHD large	1	3	Anhui Tongguan Machinery Co. Ltd.	TCY-3	3 m ³
Haul Truck	1	8	Anhui Tongguan Machinery Co. Ltd.	JZC-20	20 t
Services Platform	1	1	Anhui Tongguan Machinery Co. Ltd.	JY-5	5 t
Personnel Carrier	1	1	Anhui Tongguan Machinery Co. Ltd.	JY-5YR-16	16 persons
Shotcreter	1 & 2	2	Hunan Changde Shotcrete Machinery Factory	HPZ-6	6 m ³ /hr
Electric Locomotive	2	6	Jilin Longed Iron Alloy Co. Ltd.	ZK3-6/250	20.9 t
Electric Loader	2	30	Nanchang Hengye Mining and Metallurgical Machinery Factory	Z-30	0.3 m ³
Rail Cars	2	100	Henan Hebi Mishi Machinery Co. Ltd.	YCC0.7-6	0.7 m ³
Auxiliary Stopping Fan	1 & 2	40	Zib Ventilation Machine Plant Ltd.	JK56-N ₀ 4	0.1~3.4 m ³ /hr
Auxiliary Development Fan	1 & 2	20	Zib Ventilation Machine Plant Ltd.	JK-58N ₀ 4	2.2~3.5 m ³ /hr
Mobile Refuge Chamber	1 & 2	3	Chongqing Research Institute of China Kegong Group Corp.	JYZY-96/12A	12 person, 96 hrs
Static Refuge Chamber	1 & 2	5	Xuzhou Yongxing Mechanical Manufacture Ltd.	ACYX-24	24 person, 120 hrs

Table 16.10 summarizes the type and capacity of the fixed plant.

Table 16.10 Silvercorp fixed plant summary

Silvercorp equipment	Stage	Units	Manufacturer	Model	Capacity
JKMD-2.8 x 4 Multi-rope Friction Hoist - Cage	2	1	Citic Heavy Machinery Manufacturing Company Ltd		1,200 t/day - ore+waste
Primary Fan	1 & 2	2	Shandong Befeng Ventilation Machine Ltd	DK-40-8-No25/2x200	62.9-150.4 m ³ /sec
Waste and Service Cage	2	1	Xuzou Coal mine safety equipment Limited	4# lengthen cage	
Multiple Stage Centrifugal Pump - 50 mRL	2	3	Changsha Canon General Pumps Company Ltd	200D65B	Q=200 m ³ /hr, 344 m head
Multiple Stage Centrifugal Pump - 300 mRL	2	3	Changsha Canon General Pumps Company Ltd	D155-30x8	Q=155 m ³ /hr, 140 m head
Air Compressor - Ramp	1 & 2	2	Atlas Kunxi Compressor Company	QGD250AC	40 m ³ /min at 0.8 Mpa
Air Compressor - Main Shaft	1 & 2	2	Atlas Kunxi Compressor Company	QGD250AC	40 m ³ /min at 0.8 Mpa

16.12.1 Equipment productivities

Table 16.11 summarizes the productivities assumed for the development and production activities.

Table 16.11 Development and production activity productivities

Development or production activity	Unit	Schedule rate	Machine type
Jumbo - Single Heading (Ramp)	m/mth	180	Single Boom Electric-Hydraulic
Jumbo - Single Heading (Levels)	m/mth	80	Single Boom Electric-Hydraulic
Jumbo - Multi Heading (Levels)	m/mth	240	Single Boom Electric-Hydraulic
Jackleg - Single Heading (Levels)	m/mth	70	Jackleg (YT-24)
Jackleg - Multi Heading (Levels)	m/mth	200	Jackleg (YT-24)
Jackleg - Stope Raises	m/mth	60	Jackleg (YT-24)
LHD - Stope Mucking	t/mth	30,000	TCY-3 (3 m ³)
LHD - Development Mucking	t/mth	16,000	TCY-2A (2 m ³)
Truck - Production (to ROM Stockpile)	t/mth	14,000	JZC-20 (20 t)
Truck - Development (to Waste Dump)	t/mth	13,000	JZC-20 (20 t)
Rail Loader - Development & Stope Mucking	t/mth/level	13,000	Z-30 (0.3 m ³)
Rail Trucks - Production & Waste (to Main Shaft)	t/mth/level	24,000	ZK3-6/250 Loco & 10xYCC0.7 m ³ cars

16.13 Mine personnel

Silvercorp operates the mine using contractors for development, production and the operation and maintenance of Silvercorp's fixed plant, with Silvercorp providing its own management, technical services and supervision staff to manage the GC Mine.

The mine is operated on a continuous roster for 365 days per year working three 8 hour shifts per day.

Figure 16.11 summarizes the Silvercorp employee numbers from year 2011 to 2017. These numbers exclude General and Administration (G&A) personnel, geological drilling, external consultants and process plant operation. The numbers depict people on-site at any point in time and do not account

for the off-site labour panels, sick leave, absenteeism, annual leave, turn-over, etc. The contractor employee numbers are approximately 265 for all years.

Figure 16.11 GC Mine operations labour

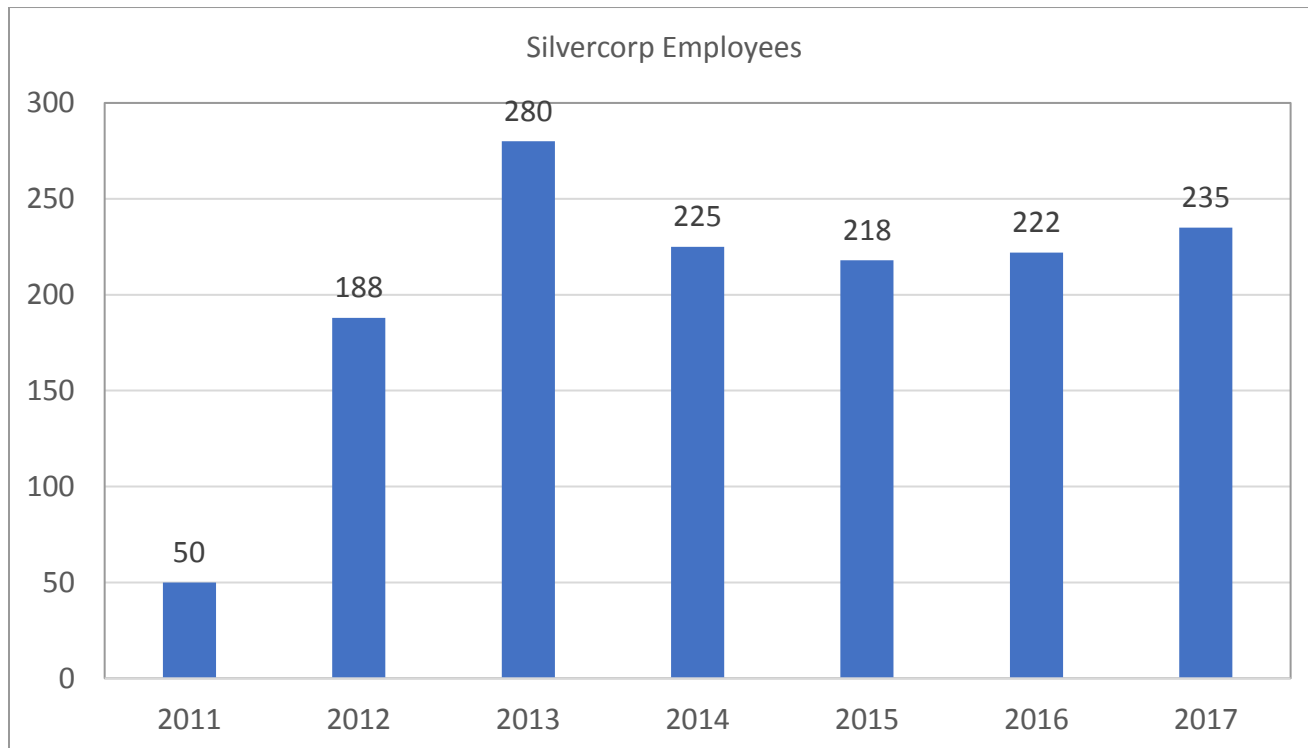

16.14 Mine safety

Mine safety is practiced as set out by Chinese health and safety laws and regulations.

There is an OHS department for the GC Mine, staffed with three mine safety trainer officers and seven technicians.

The mine and mining contractors are tasked with providing appropriate Personal Protective Equipment (PPE) to their own staff or miners. The PPE available includes protective cloths, hard hats, safety boots, work gloves, face masks, and ear plugs.

The OHS departments provide safety training, enforce the OHS policies and procedures, make recommendations on mine safety issues and carry out daily inspections of the underground workings and explosive usages.

Safety committees are headed by the General Manager and made up of the Deputy General Manager, Mine Superintendent, Safety Department Supervisor, and representatives of the mining contractor. The committees are co-ordinated by the GC Safety Department. The mine management and the safety officers are required to have valid mine safety training certificates issued by the Provincial Bureau of Safe Production and Inspection.

With respect to safety in general, AMC recommends that Silvercorp continue with a focus on safety improvement, including implementation of a policy where the more stringent of either Chinese or Canadian safety standards are employed.

16.14.1 Fire prevention

Water for fire protection is provided via the Ramp Shaft and Main Shaft with 200 t surge capacity. Primary reticulation and secondary reticulation is by 108 mm and 89 mm nominal bore pipes respectively, which are installed and maintained in accordance to national safety standards (Safety Regulations on Metal and Non-metal Mining Operation – National standard GB16423-2006).

Fire extinguishers are provided and maintained in accordance with regulations and good practice at the electrical installations, pump stations, service workshops, and locomotive garage and wherever a fire hazard is identified to exist.

Visible fire signs and fire safety notices are posted in appropriate areas.

A suitable number of fire extinguishers are provided and maintained at each stationary diesel motor and transformer substation.

Every light duty vehicle carries at least one fire extinguisher of adequate size and proper type.

All heavy duty mobile mine equipment - loaders, trucks, drills, charge-up machines, etc. - are equipped with on-board fire suppression systems.

A mine-wide warning system is installed at the main mine intake airway entries to alert underground workers to the event of an emergency. This consists of audible alarms, ventilation status lights and stench gas.

16.14.2 Mine rescue

Fully trained and equipped mine rescue teams are site-based with team members provided by the mining contractor and maintained on-site at all times. The mine rescue teams are trained for surface and underground emergencies.

A mine rescue Emergency Response Plan has been developed and is kept up to date.

A mine rescue room is provided in the surface mine offices adjacent to the Main Shaft.

An emergency clinic is maintained on-site and manned by a physician 24 hrs per day. Silvercorp also has a contract established with the Yunfu General Hospital to provide emergency services and ambulance extraction to the hospital.

16.14.3 Dust

All broken rock is wet down using hoses and sprays after blasting, prior to mucking and during mucking.

Decline roadway dust suppression uses a water cart with sprays on an as-needed basis.

Regular dust monitoring is conducted as per regulatory requirements.

Personnel working in dust generating work areas are provided with personal dust respirators.

16.14.4 Emergency egress

Egress to surface is available via all ventilation shafts, the Ramp, the Main Shaft and the ML6 adit connected to the +100 mRL level.

The Main Shaft and ventilation shafts are equipped with staged ladder ways incorporating general mine services and partitioned from other shaft activities; they are provided with appropriate ventilation profile clearance and established in accordance with good practices.

Lateral egresses are appropriately sign posted and maintained for walking access.

16.14.5 Mine refuge stations

A permanent refuge station is located at -300 mRL in the bottom of the Main Shaft.

Static and / or mobile refuge stations are established on each mine level with the exception of the +100 mRL, which is not a production level.

The static refuge stations or mobile refuge chambers are established in accordance with good practices with independent air supply (compressed or oxygen), communications, first aid, etc. and are of appropriate capacity to cater for the labour numbers in the active mine areas.

For the +50 mRL, 0 mRL, and -50 mRL levels, mobile mine refuge chambers are located in close proximity to the active development and production stopes in redundant stockpile areas.

For the remaining levels from -100 mRL to -300 mRL static mine refuge stations are located adjacent to the Main Shaft.

16.14.6 Ablutions

Facilities are provided on each working level in the middle section adjacent (approximately Mine Section 32) to a return airway and are cleaned and disinfected on a regular basis.

17 Recovery methods

17.1 Introduction

The key outcomes from the metallurgical testwork are presented in Section 13.6, and recent operating performance is summarized in Section 13.7. Prior to the start of operations, items of direct pertinence to discussion on recovery methods were seen to be the following:

- The silver mineralogy indicates an optimization opportunity in increasing silver recovery from all species, including sphalerite and pyrite, to the lead concentrate, within the constraints of the minimum % Pb specifications. This has implications for lead cleaner circuit and filtration capacity.
- There was no comminution testwork to serve as a basis for the crushing and grinding circuit design.
- The flotation testwork culminating in the closed circuit test provided an adequate basis for the flotation process design.
- Some circuit options had been investigated, specifically copper-lead separation and tin recovery, and although these had been included in the GMADI Design Instructions, neither had been included in financial modelling.
- AMC considered the copper-lead separation not to be viable, but in any case, to be of such a small scale and therefore of such limited materiality that it was of little consequence to projected operations. Moreover, there was only limited Cu resource data to support any copper recovery process.
- On the other hand, AMC believed that a tin recovery circuit did have potential merit and although the base case of for operations did not include such, it was considered as an opportunity and a material circuit option.

Since the start of trial operations in 2013 and commercial production in 2015, lead and zinc concentrates have been produced in commercial quantities at the Gaocheng mill (see Table 13.5). The process flowsheet and other key aspects of the processing operation are discussed below. Of further note is that some small amounts of tin concentrate and sulphur have also been produced but that these quantities have not been significant enough to be material to mine economics.

17.2 Process flowsheet

The process flowsheet is shown schematically in Figure 17.1, being very similar to the process adopted in the closed-circuit flotation tests described in Section 13.4.3, and with the tin recovery circuit also shown.

No significant alterations have been made to the plant since completion of commissioning, and it has processed approximately the same amount of ore each year (261 ktpa to 244 ktpa).

Figure 17.1 Process flowsheet

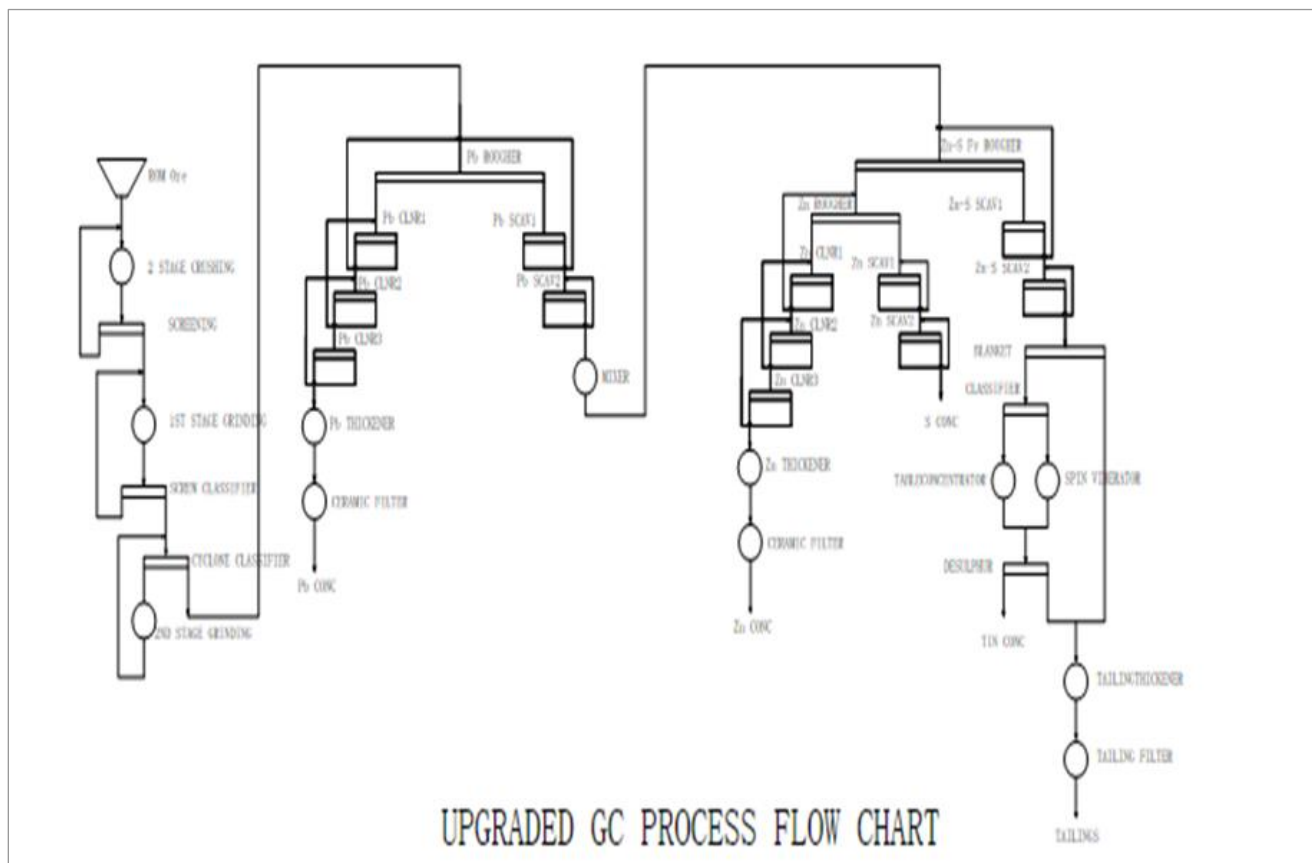

17.3 Process description

17.3.1 Summary

The overall process consists of crushing, grinding, sequential flotation of lead, zinc, and pyrite concentrates, and concentrate dewatering by disc filtration. An experimental tin recovery gravity separation circuit is installed on pyrite flotation tails.

Two-stage crushing is carried out, with the second stage in closed circuit. Run of mine ore at -350 mm is reduced to crusher product at -10 mm. This is followed by two-stage grinding in ball mills to a product size of 80% passing 75 µm (P₈₀ of 75 µm).

The flotation process consists of a standard flotation of lead, with three-stage cleaning of the lead concentrate, then flotation of zinc concentrate with three-stage cleaning; leaving pyrite tailings as S concentrate. Concentrates are dewatered by conventional thickening and filtration.

The experimental tin recovery circuit treats Zn scavenger flotation tailings. It comprises spiral classification, followed by coarse and fine gravity concentration using shaking tables, with a final stage of flotation to remove residual sulphides.

The process design was based on the following overall throughput assumptions:

- 1,000 tpd feed base case (potential expansion to 1,600 tpd if required).
- 330 days per year.
- Crushing 18 hrs/day.
- Grinding-flotation, etc. 24 hrs/day.

Daily throughput to date has been approximately 800 tpd. Annual throughput of 264,000 tpa can be estimated using the following assumptions:

- Feed rate: 42 tph
- Daily utilization of time: 80%
- Annual days worked: 330 days

The required steps to increase daily throughput to 1,600 tpd have been identified. AMC considers necessary availability and utilization factors for 1,600 tpd to be reasonable and in line with normal mining industry practice. In all sections of the plant, space / capacity has been allocated for an expansion to 1,600 tpd (mine feed to the mill at around 500,000 tpa). The implications of this are discussed in the section descriptions following.

A general site plan is shown in Figure 17.2.

Figure 17.2 Processing plant site plan

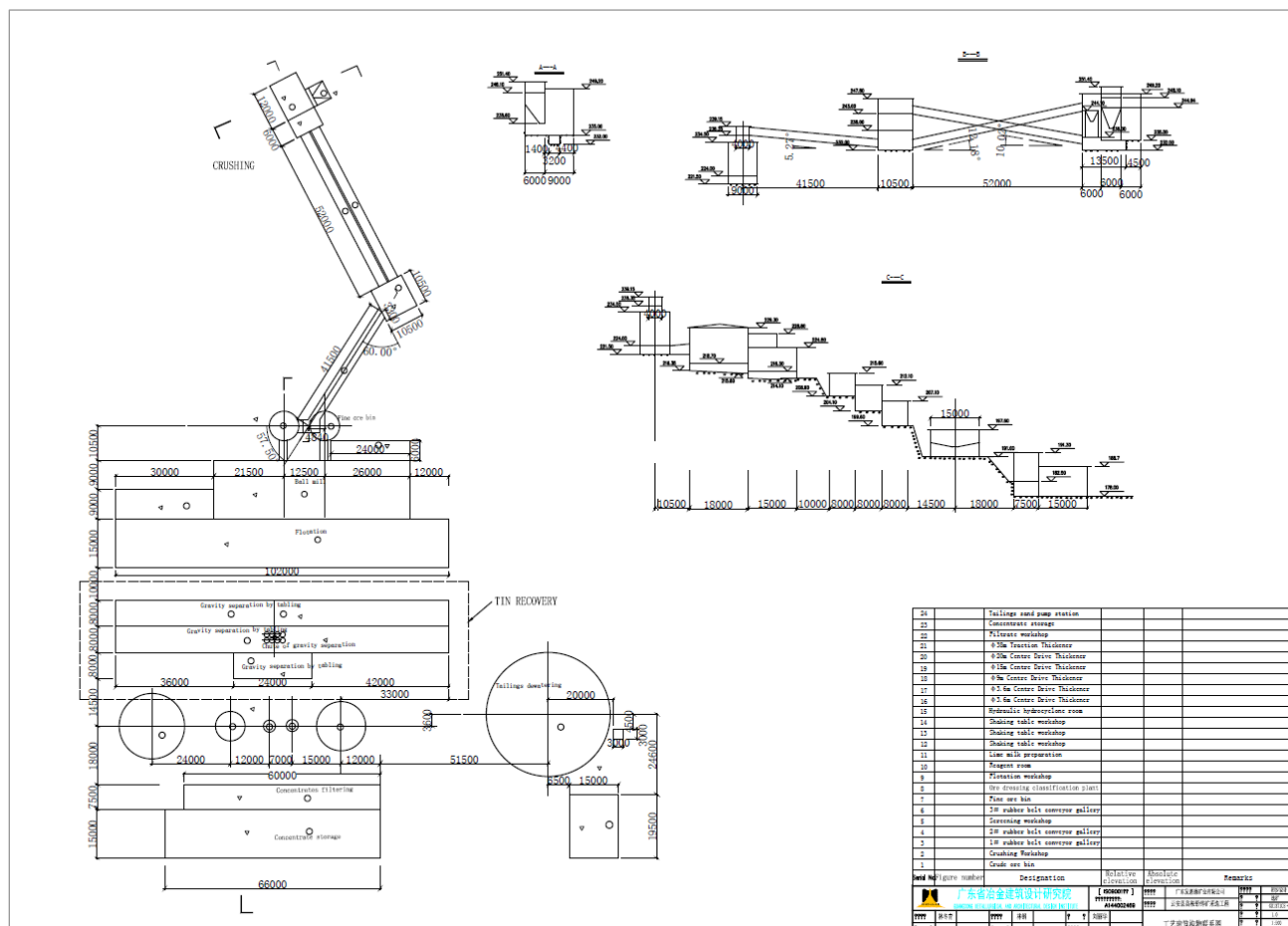

17.3.2 Crushing

The crushing circuit consists of a run-of-mine ore bin from which the ore is drawn by a vibratory feeder into the primary jaw crusher. The jaw crusher product is screened on a vibrating screen with the -10 mm fines being conveyed forwards to the fine ore bin while the +10 mm material feeds the secondary cone crusher via a buffer storage bin to maintain choke feeding of the crusher. The fine ore bin has a capacity of 1,600 t.

Figure 17.3 Surface grizzly feed to ROM ore bin



17.3.3 Grinding

In similar fashion to the crushing section, the two-stage grinding circuit is sized for 1,600 tpd.

Given that 1,600 tpd may be the ultimate throughput, four mills with 400 kW motors have been installed.

Typical of Chinese practice and conforming to the design successfully used at Silvercorp's Ying mine, the grinding circuit consists of a grate-discharge ball mill in closed circuit with screw classifier followed by an overflow ball mill in closed circuit with hydrocyclones to achieve the desired flotation feed size of 80% passing 75 μm (P_{80} of 75 μm) in the cyclone overflow. The primary mills have weightometers fitted to the feed conveyors linked to a variable speed belt motor for mill feed control.

The circuit is configured in two parallel trains, each of 800 tpd capacity, for reasons of flexibility and ease of maintenance.

Figure 17.4 Grinding mills and spiral classifier



17.3.4 Flotation

Following on from the grinding circuit, the flotation circuit is similarly configured in two parallel trains.

The flotation cell sizing is adequate for 1,600 tpd, with rougher residence time designed to be a minimum of 15 minutes (mins) plus scavenger time, also of 15 mins. Conditioning times of the order of five mins apply.

The general layout is compact and efficient, making use of gravity and the sloping site terrain as the banks follow successive parallel contour lines.

Figure 17.5 shows a general arrangement plan of the grinding and flotation section. Figure 17.6 shows flotation machines on a flotation deck.

Figure 17.5 Grinding / flotation plant general arrangement

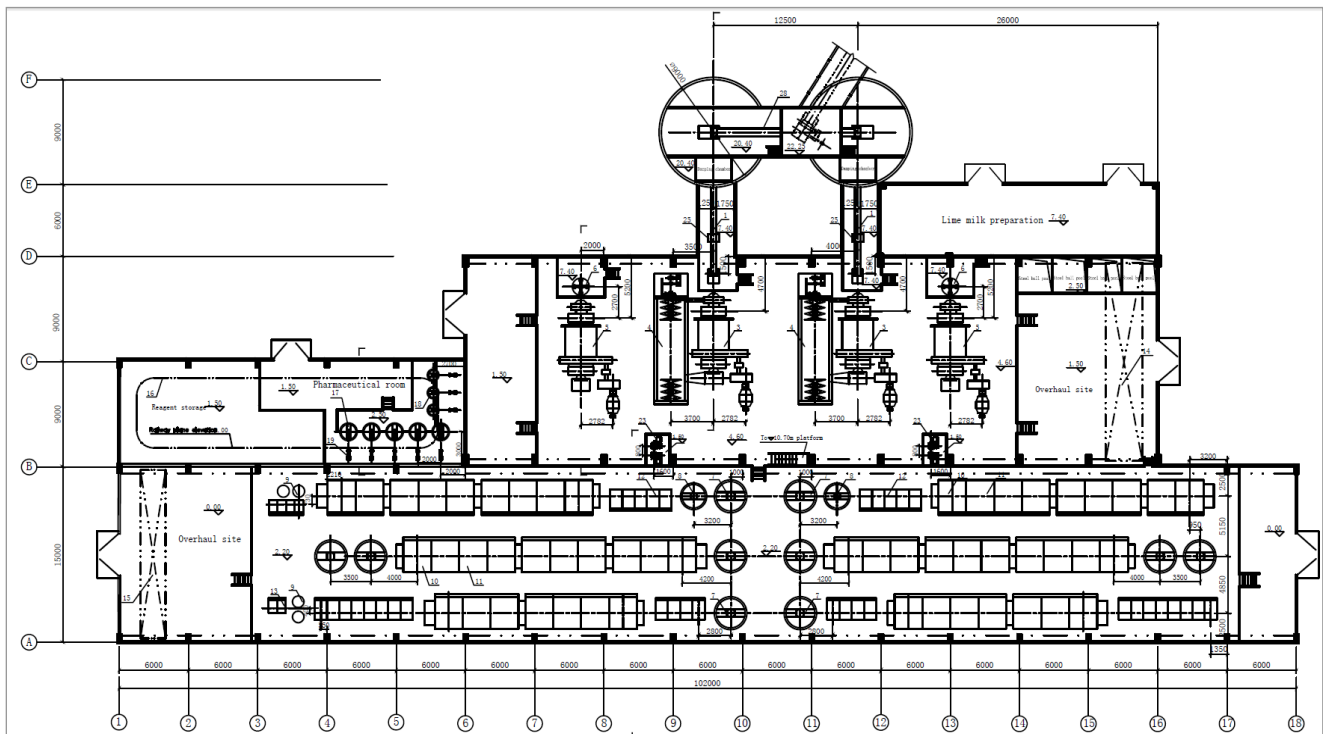

Relative elevation of ±0.00m is equal to absolute elevation 214.1m in this figure.
All elevations are process internal elevations in this figure.
Elevation is measured in meters in this figure.
Distance is measured in millimeters in this figure.
Lime milk preparation is showed in the figure of GD1371CS-X-15.

29	HS-0.5A handle pulley Q=0.5t	1				0.007	0.007	
28	4# Reversible belt conveyor with windrows 4000*1000	1		7.5	1	3.80	3.80	
27	CD11-6D electric hoist Q=1t	1		1.7	1	0.137	0.137	
26	Storage medicine barrel Φ1500×1500	8				0.56	4.48	
25	Nuclear Belt Balance (B=650)	2		3.0	2	0.90	1.80	
24	Reagent Feeder JT-32	1		2.0	1	7.20	7.20	For automatic reagent feeding control system
23	Slurry Pump 4/3C-AM(B)	4		30.0	4	0.72	2.88	1 Set of 4C, 1 set of AM and 1 Set of 3C. Temperature 2.0°C max.
22	2PNL Vertical Slurry Pump	2		6.9	2	0.28	0.56	Used for the flotation working agent feed
21	Slurry Pump 20LS-A	2		4.3	2	0.36	0.72	Used for slurry concentration. 1 Set of 20LS-A, 1 Set of 20LS-B
20	Pipeline Sampler	7						
19	Chemical Pump IH50-32-125A	8		1.91				
18	Reagent Agitating Vat Φ1000×1000	3	Y90L-6	1.1	3	0.532	1.60	
17	Reagent Agitating Vat Φ1500×1500	5	Y132S-6	3.0	5	1.36	6.8	
16	CD10-6D Electric Hoist Q=2t	1		3.4	1	0.232	0.232	
15	L Type Electric Singlebeam Crane Q=5t LX-15.5	1	ZDT21-4	1.6	1	2.80	2.80	
14	L Type Electric Bridge Crane Q=16t LX-16.5	1		27.4	1	15.0	15.0	
13	Flotation Machine BF-0.37	6	Y90L-4	1.5	6	0.47	2.82	
12	Flotation Machine BF-1.2	34	Y132M-6	5.5	34	1.37	46.58	
11	Flotation Machine MCF-10	36		22.0	36	4.334	156.02	
10	Flotation Machine MCF-10	16		30.0	16	4.894	78.31	
9	Ore Slurry Mixing Bucket Φ1000×1000	4	Y90L-6	1.1	4	0.532	2.12	
8	Ore Slurry Mixing Bucket Φ2000×2000	2	Y132M-6	5.5	2	1.67	3.34	
7	Ore Slurry Mixing Bucket Φ2500×2500	10	Y180L-6	15	10	3.44	34.4	
6	Hydraulic Cyclone Φ300mm	8				0.17	1.36	2 series, 3 For utilization and 1 for standby
5	Wet Overflow Ball Mills MQG2700×2700	2	JR140-S	310	2	66.0	132.0	2 series, 1 For utilization and 1 for standby
4	Hidrewit Type Single-spiral Classifier NP-04	2	Y100L-4 Y100L-4	3.0 15.0	4	28.65	51.3	1 set of NP-04, 1 set of NP-04B, 1 set of NP-04C, 1 set of NP-04D
3	Wet Grate Ball Mills MQG2700×2700	2	JR140-S	310	2	66.0	132.0	2 series, 1 For utilization and 1 for standby
2	Disk Ore Feeder DK10	4	Y100L-6	1.5	4	0.79	3.16	1 set of DK10, 1 set of DK10B, 1 set of DK10C, 1 set of DK10D
1	5# (6#) Belt Conveyor TD75-6550 L=15.5	2		3	2	1.9	3.8	
Serial No	Designation and specification	Quantity	Model	Power (KW)	Quantity	Piece weight	Gross weight	Remarks
	Equipment list		Electromotor			Weight (t)	Total: 708.1 t	
广东省冶金建筑设计研究院 GUANGDONG METALLURGICAL AND ARCHITECTURAL DESIGN INSTITUTE		[HS0000117]	*****	*****	*****	*****	*****	*****
*****	*****	*****	*****	*****	*****	*****	*****	*****
*****	*****	*****	*****	*****	*****	*****	*****	*****
*****	*****	*****	*****	*****	*****	*****	*****	*****

Figure 17.6 Flotation cells



17.3.5 Concentrate handling

The respective concentrates are thickened and then filtered on ceramic disk filters sized at 9 m², 15 m², and 30 m² for the lead, zinc, and pyrite concentrates respectively.

The filters are positioned above the concentrate storage shed for direct discharge and, from which the concentrates are loaded by front-end loader into trucks for transport to the smelter customers. Figure 17.7 shows a ceramic disc filter, and stockpiles of filtered zinc concentrate in the Zn concentrate storage shed.

Figure 17.7 Disc filters and zinc concentrate shed



17.3.6 Tin recovery circuit

The experimental tin recovery circuit is set up to treat the pyrite flotation tailings.

After an initial pre-concentration stage on eight sets of 4-start spiral concentrators, the stream is cycloned to split at 75 µm, and then the +75 µm size fraction is fed over 25 coarse (sand) shaking tables, and the -75 µm material is fed over 51 fine shaking tables. The final step is a batch flotation

stage to remove any residual sulphides also concentrated by the gravity separation processes. This takes place in a small unit in the main flotation building.

As indicated earlier, tin quantities produced to date are such as to not be material to overall mine economics.

17.4 Process control and automation

The level of process control and automation is appropriate and consists of the following key components:

- A central control room in the grinding-flotation building from which TV imaging of key operating points in the production flow can be monitored (Figure 17.8).
- Centralized monitoring of equipment run status.
- On / off interlocking of the main crushing and grinding system flows.
- Measurement and control of key parameters, including:
 - Ball mill feed tonnage.
 - Critical bin and tank levels.
 - Critical densities, e.g. screw classifier, thickener underflow densities.
 - Flotation cell pulp levels and reagent dosage.
- Automatic sampling of key metallurgical accounting streams, e.g. flotation feed, concentrates, and tailings.

Figure 17.8 Control room screens



17.5 Ancillary facilities

17.5.1 Laboratory

The laboratory is equipped with the customary sample preparation, wet chemistry, and basic photometric analytical equipment; as well as crushing, grinding, flotation and gravity-separation metallurgical testing equipment (Figure 17.9).

Routine analyses of ores and concentrates are conducted, as well as water quality and other environmental testing. The laboratory also provides a technical service to the processing plant by monitoring plant conditions, helping solve production problems and investigating new technology and new processes to assist with improvement efforts.

Figure 17.9 Laboratory



17.5.2 Maintenance workshop(s)

Daily maintenance requirements are serviced through workshop facilities equipped with craneage, welding, and basic machine-shop capabilities.

More extensive maintenance and major overhaul needs can be met through use of appropriate contractors or equipment suppliers.

17.6 Key inputs

17.6.1 Power

Total installed power amounts to 5,043 kW (includes standby equipment). Actual power drawn is of the order of 3,657 kW, which corresponds to 28,963,000 kWh per annum. Note that this includes tailings return water pumping.

17.6.2 Water

With the use of dry stacking of tailings there is minimal lock-up of water in tailings and a close to 90% recycle of water from the recycled water pond; however, there is a requirement for some fresh water, of the order of 0.4 m³ per tonne of plant feed, for items such as pump seals, cooling units and reagent mixing.

Total water demand (including recycle) is approximately 3,200,000 L/day (4 m³ per tonne of ore processed). 6,000,000 L/day of water is projected at 1,600 tpd production.

17.6.3 Reagents

Reagent storage and mixing is located adjacent to the grinding / flotation plant and comprises a storage area with hoisting equipment to lift bags and drums through into the mixing area.

The reagents in this area are:

- Depressant / modifiers
 - Sodium sulphide
 - Zinc sulphate
 - Sodium sulphite
 - Copper sulphate
- Collectors
 - Di-ethyl dithiocarbamate
 - Ammonium dibutyl dithiophosphate
 - Butyl xanthate
- Frother – no. 2 oil (added directly)

From the mixing area the reagents are pumped up to the dosing station located above the flotation section for dosing and gravity feeding to the various addition points.

Since the usage of lime is large (8 kg/t) the lime storage and milk-of-lime mixing area is separate, but also adjacent to the grinding / flotation plant. Milk-of-lime storage tanks have grit removal submersible pumps.

The sulphuric acid tank and dosing pumps are also located separately, for reasons of safety.

17.7 Summary

The recovery methods used for the GC deposit are appropriate for the ore characteristics. The following specific comments apply:

- The flowsheet is fit for purpose and has demonstrated that it can achieve targeted recoveries and concentrate grades.
- The comminution circuit, especially grinding, performs well for the current 800 tpd operation, and is also adequate for a 1,600 tpd throughput level.

- Drawing on the design data provided and on the site visit to the operating Ying mine, AMC concludes that appropriate equipment has been selected and that the plant layout is practical and functional.
- Ancillary facilities are adequate.
- The trial tin recovery circuit yields quantities that are not material to the commercial viability of the operation.

18 Project infrastructure

18.1 Tailings Management Facility (TMF)

18.1.1 Overview

The tailings deposition method is dry stacking and filling (from bottom to top and stacking by bench to form the embankment) with concurrent rolling and compaction.

In the 2012 Gaocheng Technical Report, AMC made the following comments, along with others, with respect to the proposed TMF:

Although AMC believes that the basic concept is reasonable, and in any case, dry stacking usually has less onerous requirements than slurry tailings storage, nevertheless the work carried out to date towards the TMF design does not meet feasibility study standards. AMC considers that the following areas of deficiency need addressing:

- Tailings properties determination is critical for dry stacking as the tailings are effectively their own containment and so requires additional testwork including:
 - Proctor compaction tests to derive target moisture levels for the required compacted density.
 - Shear tests to assess the internal strength of the tailings as an input to stability analysis.
 - More comprehensive size analysis, to include potential clay component size range.
 - Geochemical characterization e.g. metal leaching tests.
 - Filtration tests to assist in the pressure filter sizing to meet target moisture levels.
- Site investigations are required including:
 - Geotechnical evaluation of underlying bedrock etc.
 - An assessment of the implications of the Gaocheng River class II water resource classification for the TMF location and design.
- Although the TMF design meets storage capacity requirements, the following work is still required:
 - A site-specific risk assessment as opposed to the generic grade III design criteria within the Chinese volume-height categories.
 - A re-assessment of factor of safety calculations using standard industry practice finite element numerical modeling.
- A more detailed water balance on a month-by-month basis is required since the project is situated in the monsoon belt with 70% of annual precipitation falling in the summer months.

AMC has now observed the actual TMF on site, which has been functioning since the start of mining and processing operations in 2014. The TMF operation and dry-stacking process appear to be taking place as planned, and with drainage installed as described below and as shown in Figures 18.3 and 18.4. AMC also notes that the latest TMF risk assessment report was approved on 14 May 2018 and that site-specific risk assessment is carried out every three years or as requested by Government departments.

18.1.2 Site selection

Two possible sites for the TMF were considered initially, one immediately to the south of the mine and concentrator in the Daken valley and the second 5 km to the south-east in the Heliken valley.

The Daken valley site was selected on the basis of:

- Proximity to the concentrator.
- No residential or industrial developments although there was some small scale farming within the proposed site.
- Small catchment area and adequate storage capacity.

Data on site conditions consisted of:

- Rainfall data (annual average 1,493 mm with 70% of that occurring in the April to August period).
- Surficial geology: quaternary residual overlying shales and schists, no known structures.
- Seismic intensity rating according to the Earthquake Intensity Zoning Map of China (2002) of VI (the intensity scale is similar to the Modified Mercalli, i.e. in this case "slightly damaging").

AMC understands that no site specific geotechnical field investigations have been carried out with respect to geotechnical drilling to bedrock beneath the main containment structures.

The TMF location, along with other surface infrastructure, is shown in Figure 18.1 and Figure 18.2.

Figure 18.1 Plan of surface facilities, GC Project

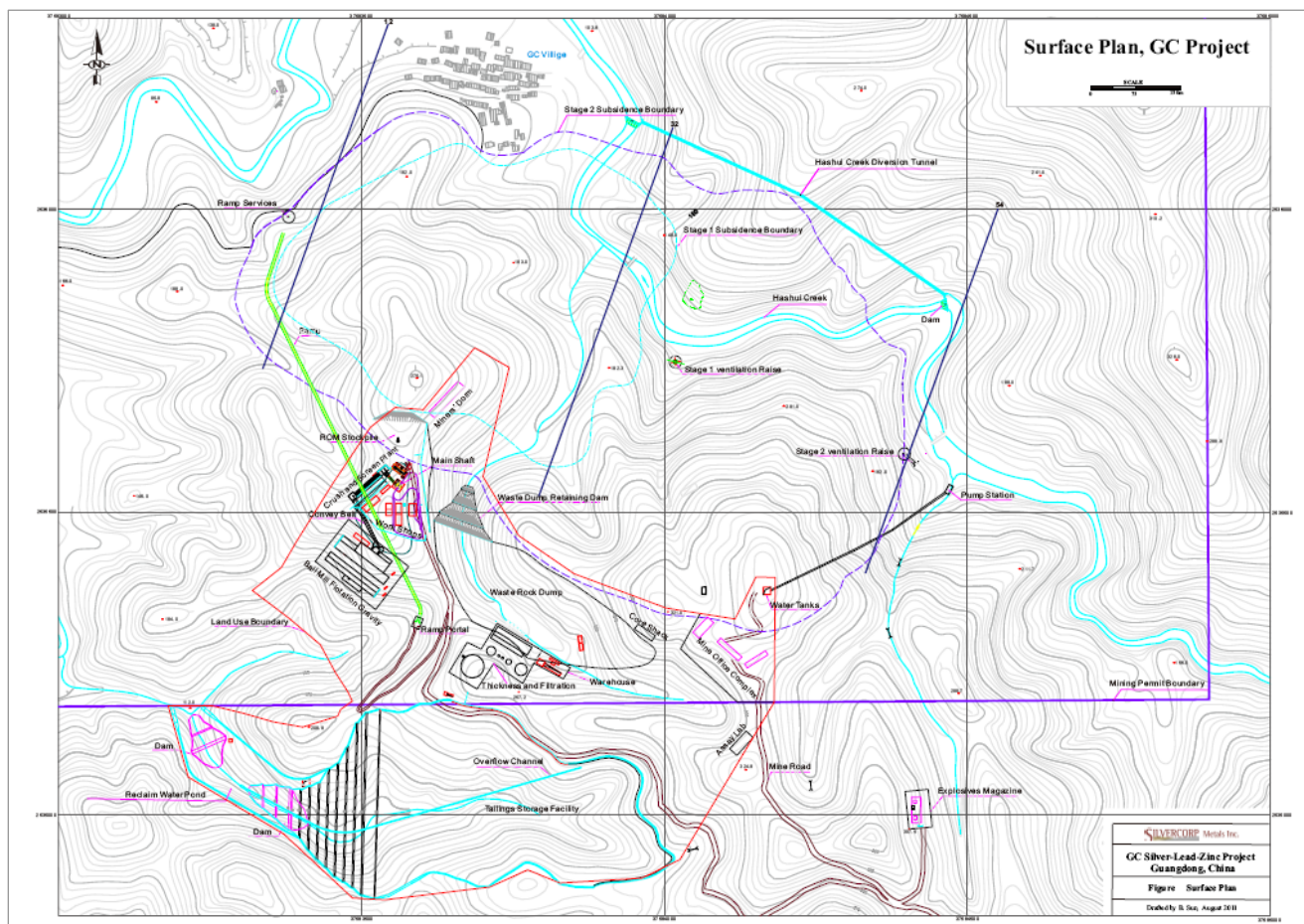

Figure 18.2 Satellite aerial view of surface facilities, GC Project



18.1.3 TMF design and assessment

Storage capacity calculations for the Daken valley site under the bottom to top dry stacking by bench method indicated a total storage volume of 3.57 Mm³. At a dry density that is now understood to be close to 2.0 t/m³, the equivalent tailings tonnage is of the order of 7.0 Mt. This is more than adequate for the tonnage of tailings in the LOM production schedule.

The design criteria under the Chinese system are based solely on the height and volume, which places it within a Grade III facility (i.e. mid-range in the I-V system). A site-specific risk assessment is one of the pre-conditions to renew the TMF Safety Production Certificate. As noted above, a site-specific risk assessment is carried out every three years or as requested by the relevant Chinese Government departments, and the most recent TMF risk assessment report was approved on 14 May 2018.

The first TMF Safety Production Certificate was granted in 2014. On 4 September 2017 the TMF Safety Production Certificate was renewed and is valid until 3 September 2020.

The TMF was designed as Class III under Chinese TMF classification criteria but was assessed as IV under the same criteria. Table 18.1 shows key metrics of the design and latest assessment.

Table 18.1 Key metrics of design and latest assessment

	Unit	GC TMF	Remarks
Year built		2013	Completed on 15 July 2013
Start operation		2014	
Total volume	(Mm ³)	3.57	Designed volume
Remaining working volume	(Mm ³)	2.99	Assessed September 2017
Service life	(yr, design)	22	Assessed 15 yrs
Remaining life	(yr)	15	At September 2017
Tailing production rate	(tailing, tpd)	783.6	
Stacked volume	(Mm ³)	0.49	Assessed September 2017

The TMF consists of an initial earth retaining dam, behind which the tailings are delivered by a system of conveyors and then spread by bulldozer on a bench by bench basis with concurrent rolling and compaction to the desired dry density standards. The resulting construction is a tiered tailings embankment gradually rising up the valley. Figure 18.3 shows the dam and water seepage. Figure 18.4 shows dam water catchment setup.

Figure 18.3 GC TMF dam and water seepage



Figure 18.4 TMF dam water catchment



Seepage control is effected by geomembrane and geotextile impervious layers together with an intercepting drain and collector system discharging into a downstream water storage dam for pumping to the concentrator.

Particular aspects of the TMF design and assessment have included:

- Water drainability analysis: based on area precipitation records, rain water collection area and slope of the topography, and resulting requirements for discharge ditches and water discharge pipes under extreme circumstances.
- Tailings dam seepage analysis: based on the elevation of underground water during extreme rainfall and the permeability coefficient of the rocks, to determine the location of the seepage line and the slope of the underground water. This analysis suggested that the seepage line is not exposed and there would be no seepage, even in case of heavy rain.
- Tailings dam stability analysis: based on information such as material used for dam construction and geotechnical characteristics of the dam foundation. The anti-slip stability factor was calculated to be 1.427, which is significantly higher than the value of 1.1 in the case of extreme heavy rain that AMC understands is required in China.
- TMF monitoring system: online monitoring equipment installed includes the following:
 - Online seepage line monitoring system.
 - Dam displacement GPS monitoring system.

- CCTV monitor system.
- Precipitation alarming system.

AMC understands that a safety and reliability analysis for the TMF was previously carried out in accordance with the Safety Technical Regulations for Tailings Ponds (AQ2006-2005) and under the Grade III requirements. AMC also previously referenced that the methodology used was now considered outdated and industry practice would be to conduct finite element numerical modeling.

AMC notes that flood calculations have been indicated as being performed appropriate to the Grade III classification of the TMF, under a dry stacking scenario, which requires the flood control measures to meet a 1 in 100 year recurrence interval for design purposes with a 1 in 500 year probable maximum flood criterion also.

As referenced above, the most recent TMF risk assessment report was approved on 14 May 2018 and the TMF Safety Production Certificate was renewed on 4 September 2017. That notwithstanding, AMC recommends that Silvercorp continues to satisfy itself, as per best industry practice, that all fundamental aspects of the TMF design, construction and operation have been and continue to be satisfactorily addressed. This may include geotechnical drilling of the dam foundation area, as it is AMC's understanding that such activity has not specifically been undertaken.

18.1.4 Tailings delivery

The concentrator tailings are thickened in a conventional rake thickener and then filtered in plate and frame pressure filters of Chinese manufacture at the filtration plant situated immediately adjacent to the TMF.

The two XA90/920 filters selected were sized for 1,000 tpd ore feed and have proved to be of adequate capacity for the tonnages processed to date.

The filtered tailings are conveyed to the TMF delivery point via conveyor belts, with subsequent spreading and stacking as previously described.

18.2 Waste rock dump

The + 215 mRL waste rock dump is located a short distance to the east of the mine portal. It is understood to have an immediate capacity of the order of 275,000 m³ (~558 kt). AMC's previous site observations and review of surface plans referenced that there appeared to be room for a downstream extension of the waste dump location and / or ability to increase the waste dump height to approximately +300 mRL to accommodate all waste produced over the LOM.

As noted earlier, however, waste rock produced to date has largely been used for construction purposes by Silvercorp or transported off-site by local area persons, free of charge, again to be used for construction activities. Waste dump areas on site are thus empty. The removal of waste rock from site is anticipated to continue for the foreseeable future.

Also, as noted earlier, waste rock could opportunistically be disposed of into shrinkage stope voids (with approximately 1.2 Mm³ or 2.3 Mt void capacity) but this is not in the current mine plan.

Based on the GC environmental assessment report, AMC understands that waste rock at the GC mine has no significant acid-generating potential.

18.3 Power supply

There is a 110 kV substation near Gaocun, about 6 km from the mining area. This is fed from the Guangdong Province electrical grid system. Silvercorp uses this substation as the main source of power for the mine. Currently there are for two overhead power lines for the 6 km route. Two 1,500 kW diesel generators are designated for emergency backup to the man-hoist, underground ventilation system, water pumping and essential services in the plant.

A new 10 kV substation was built in the mining area to provide power service for the entire mining area. The power supply and distribution in the process plant, mining area, administrative and living areas are configured based on needs. Figure 18.5 is a view inside the substation compound.

Figure 18.5 GC mine substation



According to Chinese standards the electrical loads are sub-divided into three classes. Underground dewatering and the man-cage belong to first class. At peak dewatering, the working capacity of first class load is estimated at 1.7 MW. The total installed capacity above the second class load is 12.3 MW, working capacity is 10.1 MW, calculated load is 6.7 MW, apparent power is 7,612 kVA, and annual electricity consumption is of the order of 39,000,000 kWh.

18.4 Roads

Access to the GC project from Guangzhou is via 178 km of four lane express highway to Yunfu, then 48 km of paved road to the project site. A railway connection including high speed rail from Guangzhou to Yunfu is also available.

There are 15 roads assigned to this project, some are site and others general access roads. There are no issues re transport of large equipment and / or ore concentrates transportation.

18.5 Transportation

Trucks under escort by security personnel are used to transport lead and zinc concentrates from the mine site to refineries. A front-end loader is used to load the concentrate from storage sheds near filters at the mill site to the concentrate shipping trucks.

18.6 Water supply

See Section 16.11.2.

18.7 Sewage treatment

A sewage treatment station is located at the mine site for processing of mine camp sewage.

18.8 Mine dewatering

See Section 16.11.3.

18.9 Water treatment facility

Figure 18.6 is a view of part of the water treatment facility at Gaocheng. As indicated earlier, any water that is not recycled and is released to the environment is treated to comply with standing regulations.

Figure 18.6 GC water treatment facility



18.10 Site communications

A level-1 dispatching system is used for production dispatching at the mine. A 200-gate digital programmed control dispatching exchange is deployed at the dispatching room of the office building under production management personnel. To facilitate external communication, 10 pairs of trunk lines are used.

The underground communication line is in the form of a communication cable laid out along the sidewall of the drift. Two communication cables are fed to underground from different shafts. If any communication cable fails, the other has adequate capacity to assume communication with all underground communication terminals.

18.11 Camp

Silvercorp operates the mine using contractors for development, production and the operation and maintenance of Silvercorp's fixed plant, with Silvercorp providing its own management, technical services, and supervision staff to manage the GC mine operation.

Administrative, Living and Welfare Facilities are composed of administrative office building, hostel, canteen, washroom, and residential building, as well as dining and entertainment facilities.

18.12 Dams and tunnels

Silvercorp has built an approximately 1 km long diversion tunnel with two dams on the Hashui Creek to relocate the course of this river beyond the projected subsidence zone of influence (see Figure 18.1).

18.12.1 Surface maintenance workshop

The surface maintenance facilities include a workshop building area of 756.5 m², in which the following auxiliary services are provided:

- Tyre processing, maintenance, and servicing
- Welding
- Electrical
- Hydraulic
- Tools, parts, and material warehouse

The workshop is mainly responsible for maintenance of large-scale production equipment, vehicle repair, processing and repair of components, and the processing of emergency parts. One LD 10 t electric single-beam crane, one BC6063B shaping machine, one CD6240A saddle bed lathe, one Z3040 × 16/I radial drilling machine, and one bench drilling machine are located in the workshop, as well as alternating current arc welding, rectification arc welding, snag grinding machine, cut-off machine, electric drying oven, mobile air compressor, etc. Maintenance facilities such as tool rack, working platform, gas cutting device, etc. are also provided, along with a dynamic balancing machine, tire picking machine, tire mending machine, battery charger, and vehicle repair pit.

Mechanical maintenance facilities also include equipment and spare parts store, dump oil depot, reserve electric locomotives, and tramcars maintenance workshop and stockpile yard.

The mining contractor has its own mobile equipment workshop for repairs and servicing located adjacent to the Ramp portal. There are underground drill service bays established in redundant stockpile areas to minimize tramming delays for the slower moving drills.

Mobile equipment repairs (trucks, loaders, etc.), other equipment breakdowns and equipment major services are conducted in the mining contractor's surface workshop with minor services conducted in the redundant stockpile areas. Minor equipment (such as jacklegs, secondary fans, development pumps, etc.) are also serviced in the mining contractor's surface workshop.

Electric locomotives and rail cars are serviced and repaired in a service rail siding located adjacent to the Main Shaft.

Other fixed and mobile plant (primary pumps, surface electric locomotive, rail cars, vehicles, etc.) are serviced in Silvercorp's surface workshop located adjacent to the Main Shaft.

18.13 Explosives magazines

The explosives warehouse is located in the valley to the southeast of the GC Mining Area.

The surface explosives magazine is permitted to hold 10 t of bulk explosives and 15,000 detonators representing approximately 15 days and 30 days of supply respectively. Security services are used, and detonators are scanned on release from the magazine for security audit purposes.

Underground working party magazines are located adjacent to each level's return air shaft and are limited to one day of requirement for bulk explosives and three days of requirement for blasting ancillaries.

18.14 Fuel farm

Diesel fuel is required for the mobile mine equipment, some small trucks, and surface vehicles. The fuel tank and pumping station set-up allows for refueling of both light vehicles and heavy-duty mining equipment.

A properly constructed containment for storage of fuel is located in the vicinity of the diesel generators and fuel dispensing facilities. The storage facility is located down-wind from the mine air intake fans and a reasonable distance from buildings, camp, and mine portal (referencing local occupational health and safety regulations and firefighting requirement). The lined containment area is constructed such that spills are confined and can readily be cleaned, and so that the need for extensive and costly remediation work can be avoided during site closure.

The UTM coordinates of the fuel farm are 2,535,168.1 m (easting) and 37,593,487.9 m (northing). No fuel is allowed to be stored underground. Trucks and loaders are re-fueled at the surface fuel farm and dispensing facility.

18.15 Mine dry

Facilities accommodating lockers, change room, showers, and washrooms for the miners are located near the portal. Provisions for personal protective equipment such as gloves, safety glasses, self-rescuers, hard hats, and cap lamps and batteries are the responsibility of both Silvercorp and its contractor for their respective workers.

18.16 Administration building

The mine office complex to the east of the warehouse comprises the administration and engineering buildings, which provide working space for management, supervision, geology, engineering, and other operations support staff.

18.17 Assay laboratory

An assay laboratory is located in a separate modular building at the southeast side of the mill building. The laboratory is a single-story structure equipped to perform daily analyses of mine and process samples.

18.18 Security / gatehouse

A security / gatehouse is located on the site access road at the plant site. The access road off a local village road has a manual gate with signage indicating that vehicles and persons are now entering the private Silvercorp property.

19 Market studies and contracts

19.1 Concentrate marketing

AMC understands that the Gaocheng concentrates are marketed to existing smelter customers in Henan province and appropriate terms have been negotiated as detailed in Section 19.2 below.

In the 2012 Technical Report, AMC had expressed some concerns about potential arsenic levels in concentrates (0.5% As in the lead and zinc concentrates), which would potentially pose concentrate marketing problems to western smelters. AMC had also previously been able to verify from direct experience of Chinese smelter contracts that, notwithstanding the various grades within the national standards, arsenic levels up to 2 – 3% are in fact acceptable in precious metals bearing pyrite concentrate. AMC now understands that an acceptable arsenic level in base metal concentrates, without penalty, for Chinese smelters is of the order of 1.0% and notes that the GC lead and zinc concentrates are acceptable to those smelters. AMC also notes the Silvercorp concentrate selling arrangements whereby:

- Should the As level ever be higher than 1.0% in zinc concentrates, the payable Zn content would be discounted by 0.5% Zn for every 1% As above the 1.0% As level.
- For instances where the pyrite concentrate has an As content above 1.0%, a penalty is paid on a case by case basis.

19.2 Smelter contracts

Sales contracts are in place for the lead concentrates with Shandong Humon Smelting Co. Ltd., and for the zinc concentrate with Chenzhou Qiantai Industrial Co. Ltd. and Henan Yuguang Zinc Industry Co. Ltd.

All contracts have an effective period of one year, with key elements of the contracts subject to change based on market conditions when monthly supplemental agreements to the annual contracts are negotiated. AMC had previously indicated that a preferable arrangement would have been to see contracts as part of a life-of-mine frame agreement; however, it also understands that these contracts should be viewed in the context of the existing operations and concentrate sales to these smelters and therefore does not view the apparently short term of the contracts as a material issue.

All contracts have freight and related expenses to be paid by the customers.

The key elements of the contracts are summarized in Table 19.1.

Table 19.1 Key elements of smelter contracts

	Pb concentrate				Zn concentrate			
	%Pb	Deduction RMB / T Pb	Ag (g/t)	% payable	%Zn	Deduction RMB / T Zn	Ag (g/t)	Payable RMB / g Ag
Minimum quality	35		500		35		150	
Payment Scales	>50	1200	>3000	91.0	>=45	Price<RMB 15000/T: 3800	>=300	RMB1.0
	45 - 50	1350	2500 - 3000	90		Price>RMB 15000/T: 3800 + (price - 15000)*20%	150-300	RMB0.8
	40 - 45	1500	2000 - 2500	89	40 - 45	Price<RMB15000/T: 3800+50 per % lower than 45%		
	35 - 45	2000	1500 - 2000	88		Price>15000/T: 3800+(price-15000)*20%+50 per % lower than 45%		
			1000 - 1500	87.0	35 - 40	Price<RMB15000/T: 4050+100 per % lower than 40%		
						Price>15000/T: 4050+(price-15000)*20%+100 per % lower than 45%		
			500 - 1000	84.0				

With respect to lead and zinc terms, the above deductibles calculate out to 85 - 92% payable for the lead concentrate and approximately 70 - 78% for the zinc concentrate, at projected long-term prices. AMC considers these to be favourable terms relative to global smelter industry norms. Silver payables of approximately 90% are similarly in accord with industry norms.

19.3 Commodity prices

At the time of the 2012 Technical Report, silver was seen as the likely major contributor to ore value at Gaocheng. Silver prices have remained at reasonable levels but the recent advance in base metal prices and, particularly that of zinc, have elevated the importance of those metals to the Gaocheng operation. At the time of writing of this report, spot metal prices are noted in the region of: Ag \$16.75/oz, Pb \$1.14/lb, and Zn \$1.45/lb.

20 Environmental studies, permitting, and social or community impact

20.1 Introduction

Silvercorp has all the required permits for its operations on the GC Property. The exploration and mining permits are described in Section 4.1 of this report.

The existing mining permits cover all the active mining areas and, in conjunction with safety and environmental certificates, give Silvercorp the right to carry out full mining and mineral processing operations. The safety certificates have been issued by the Department of Safety Production and Inspection of Guangdong Province, covering the GC underground mine, the mill and TMF. Two environmental certificates have been issued by the Department of Environmental Protection of Guangdong Province, covering the GC project (GC Mine and 1,600 tpd mill plant). For each of these certificates, there are related mine development / utilization and soil / water conservation programs, and rehabilitation plan reports. Silvercorp has also obtained approvals and certificates for wastewater discharge locations at the GC Mine and the TMF. All certificates must be renewed periodically.

An Environmental Impact Assessment (EIA) report on the GC Project was prepared by the Guangdong Environmental Technology Centre (GETC) initially, and then reassessment is done periodically as required by regulations. The Yunfu EPB (Environment Protection Bureau) states that the mining area does not cover any natural conservation zones, ecological forests, and strict land control zones. Based on the assessment of the EIA report and the recommendations of the provincial environmental technology centre regarding site remediation, no overflow of waste water occurs, and environmental protection is maintained, the Yunfu EPB gave consent to operate the GC project with the stipulation that the scope, site, processing technique, and environmental protection measures are followed as written in the report. An Environmental Permit was subsequently issued by the Department of Environmental Protection of Guangdong Province in June 2010.

There are no cultural minority groups within the area surrounding the general project. The culture of the broader Yunan County is predominantly Han Chinese. No records of cultural heritage sites exist within or near the GC project areas. The surrounding land near the GC Mining Area is used predominantly for agriculture. The mining area does not cover any natural conservation, ecological forests or strict land control zones. The current vegetation within the project area is mainly secondary, including farm plantings. Larger wild mammals have not been found in the region. Small birds nesting and moving in the woodland are observed occasionally. The surrounding villagers raise domestic animals, such as chickens, ducks, pigs, sheep, goats, dogs, etc.

Silvercorp has made a range of cash donations and contributions to local capital projects and community support programs, sponsoring university students and undertaking projects such as village road construction, and school upgrading and construction. Silvercorp has also made economic contributions in the form of direct hiring and retention of local contractors, suppliers, and service providers to support local economy.

20.2 Laws and regulations

The GC Mine will operate under the following laws, regulations, and guidelines:

Law of Environmental Protection of the People's Republic of China (1989.12).

Law of Minerals Resources of PRC (1996).

Production Safety Law of the PRC (2002).

Law of Occupational Disease Prevention (2001-Amended 2011).

Law on Prevention & Control of Atmospheric Pollution (2000).

Law on Prevention & Control of Noise Pollution (1996).

Law on Prevention & Control of Water Pollution (1996, amended in 2008).

Law on Prevention & Control Environmental Pollution by Solid Waste (2002).

Forestry Law (1998).

Water Law (1988).

Water & Soil Conservancy Law (1991).

Land Administration Law (1999).

Protection of Wildlife Law (1989).

Energy Conservation Law (1998).

Management Regulations for the Prevention & Cure of Tailings Pollution (1992).

Management Regulations for Dangerous Chemical Materials (1987).

Law of the People's Republic of China on Environmental Impact Assessment (2003.9).

Law of the People's Republic of China on Environmental Noise Pollution Prevention (1997.3).

Law of the People's Republic of China on the Prevention and Control of Environmental Pollution by Solid Wastes (Amended in 2004.12).

Solid Waste Pollution Prevention and Control Act of Guangdong Province (2004).

Regulations on the Administration of Construction Project Environmental Protection of Guangdong Province (Tenth Standing Committee of the National People's Congress of Guangdong Province in 2004).

Notice to Strengthen Water Pollution Control of Guangdong Province (People's Government of Guangdong Province, office of Guangdong Government [1999.11.26]).

Environmental Protection Regulations of Guangdong Province (2005.1).

20.2.1 Regulation guidelines

1. Environmental Quality Standard for Surface Water (GB3838-2002).
2. Groundwater Environmental Quality Standards (GB/T14848-93).
3. Ambient Air Quality Standard (GB3095-1996, Amendment Sheet in 2000).
4. Environmental Quality Standard for Noise (GB3096-2008).
5. Emission Standard for Industrial Enterprises Noise at Boundary (GB12348-2008).
6. Noise limits for Construction Site (GB12523-90).
7. Standard for Pollution Control on the Storage and Disposal Site for General Industrial Solid Wastes (GB18599-2001).
8. Air Pollutant Emission Limit (DB44/27-2001).
9. Hygienic Standards for the Design of Industrial Enterprises (GBZ2-2002).
10. Prevention and Control on Tailings Environmental Pollution Prevention and Control (State Environmental Protection Administration in Oct. 1992).
11. Evaluating Indicator System for Lead and Zinc Industry Cleaner Production (Trial) (2007).

12. Air Pollutant Emission Limit of Guangdong Province (DB44/27-2001).
13. Environment Protection Design Regulations of Construction Project (No.002) by Environment Protection Committee of State Council of PRC (1987).
14. Regulations on the Administration of Construction Project Environmental Protection (1998).
15. Regulations for Environmental Monitoring (1983).
16. Regulations on Nature Reserves (1994).
17. Regulations on Administration of Chemicals Subject to Supervision & Control (1995).
18. Regulations on Management of Chemicals Subject to Supervision & Control (1995).
19. Environment Protection Design Regulations of Metallurgical Industry (YB9066-55).
20. Comprehensive Emission Standard of Wastewater (GB8978-1996).
21. Ambient Air Quality Standard (GB3095-1996).
22. Comprehensive Emission Standard of Atmospheric Pollutants (GB16297-1996).
23. Environmental Quality Standard for Soils (GB15618-1995).
24. Standard of Boundary Noise of Industrial Enterprise (GB12348-90).
25. Emissions Standard for Pollution from Heavy Industry; Non-Ferrous Metals (GB4913-1985).
26. Control Standard on Cyanide for Waste Slugs (GB12502-1990).
27. Standard for Pollution Control on Hazardous Waste Storage (GB18597-2001).
28. Identification Standard for Hazardous Wastes-Identification for Extraction Procedure-Toxicity (GB5085.3-1996).
29. Standard of Landfill and Pollution Control of Hazardous Waste (GB 18598-2001).

20.3 Waste and tailings disposal management

Main sources of the waste for the project are the waste rocks produced during mining and development, and the mine tailings produced during processing. There is also minor sanitation waste produced.

Waste rock produced during mining is mainly composed of silicon dioxide and calcium oxide. Currently all of the waste rock from underground mining development is taken away by local people to use as construction material or land fill. In future, as mining goes deeper, waste rock may possibly be used as fill in the mined out areas. In the case of local people no longer wishing to take the waste rock, it will be dumped, then covered by soil and vegetated after the dump is full. Retaining wall spats will be built downstream of the waste rock site for stabilization. An interception ditch will be constructed upstream to prevent the slope surface from washing away as well as to avoid water and soil loss. On closure, a soil cover will be placed, and vegetation planted.

Processing tailings are dewatered and stacked into a purpose-built tailings management facility that has an effective design capacity of 3.57 Mm³. Mine tailings are discussed in Section 18.1. After the completion of the TMF, the facility will be soil covered and a vegetation program will be conducted progressively. This is to ensure that all water flowing into the TMF does not directly contact the tailings and can be discharged to the downstream water system through the drainage ditch at the dam abutment.

20.4 Site monitoring

20.4.1 Monitoring plan

A monitoring plan has been negotiated between the company and the local environmental protection department to meet the environmental management requirements of the project. A key component of the monitoring plan is water pollution monitoring; secondary is environmental air and noise

monitoring. The monitoring work is carried out by qualified persons and / or a third party contractor and is undertaken on a regular basis.

An environmental protection department is responsible for this project. The fulltime environment management personnel are mainly responsible for the environment management and rehabilitation management work in the mining area, and part-time environmental protection personnel will be allocated in shifts for various workshops to coordinate the environmental protection work.

The monitoring plans include air quality, dust emissions, noise and waste water monitoring. The monitoring work is contracted to a licensed organization: Guangzhou Najia Testing Technology Ltd. For water environment monitoring, an intensive program has been developed and implemented, including twice-a-month testing of sanitary waste-water and surface water by Guangzhou Najia Testing Technology Ltd. Detailed monitoring plans are shown in Table 20.1.

AMC understands that monitoring results from 2013 to 2016 indicated that the surface water results are in compliance with Class II and III limits of Surface Water Environmental Quality Standards (GB3838-2002), sanitary and process plant wastewater results are in compliance with Class I limits of Integrated Wastewater Discharge Standard (GB8978-1996), and mining water results are in compliance with Class I limits of Integrated Wastewater Discharge Standard (GB8978-1996). These standards match the requirements in the EIA approvals. In addition, AMC understands that the project-stage completion inspection results were all compliant for wastewater discharge, air emission, noise, and solid waste disposal.

Table 20.1 Water environmental monitoring plan for the Gaocheng mining area

Items	Monitoring points (section)	Monitoring parameters	Frequency	Monitored by
Surface water	Hashui Creek	pH, Cr6+, NH3-N, Cd Pb, Ag, CODcr and Cu	Twice/month	Guangzhou Najia Testing Technology Ltd
Process wastewater	Discharge point after sedimentation treatment	pH	Once/month	Guangzhou Najia Testing Technology Ltd
		Pb, CODcr, NH3-N and SS	Once/month	
		Cd, S2-, As, phenol, Zn, Ag and TPH	Once/quarter	
Mining water	Discharge point after sedimentation tank	Temperature, pH, SS, CODcr, NH3-N, total P, N, SO4, Ag, Cu, Zn, Pb, Cd, Hg, phenol and TPH	Once/month	Guangzhou Najia Testing Technology Ltd

20.4.2 Water management

The Hashui Creek is shallow and is affected by the mining process, which has a minor impact on the local village area. A water retaining dam is built on the creek and irrigation wastewater from the farmland is discharged into the river. During site investigation by the GETC, large size fish were not observed in the Hashui Creek; fish fry were found moving among the submerged plants. As part of mine site preparations, the Hashui Creek was closed and diverted through a water diversion tunnel approximately 510 m in length.

Drainage construction in the project water catchment area is completed. Overflow water from the mill process waste water which is segregated by the thickener, and water generated from the tailings by the pressure filter, is returned to the milling process to ensure that waste water (include tailings water) is not discharged. Water from underground mining is reused for mining operations and the remaining water is treated according to the Surface Water Quality Standards (GB3838-2002) to meet the requirement of Class III water quality. The treated water is then stored in nearby reservoirs to be used as irrigation water for nearby woodland and farmland. The water needing to be discharged is directed to the Hashui Creek and treated to remove heavy metals such as mercury,

cadmium, chromium etc. Sewage treated by the GC sewage treatment facility is reused in mine reforestation and irrigation prior to excess being discharged into the environment. Any construction is best conducted during the dry season to reduce soil erosion.

20.4.3 Groundwater

Groundwater guidelines are contained in the Groundwater Environmental Quality Standards (GB/T14848-93). The groundwater quality meets the Class III standard with the exceptions of zinc and fecal coliform. The zinc is related to the high background level at the site and the fecal coliform is related to the local village.

Table 20.2 and Table 20.3 show ground water testing results at Gaocheng village.

Table 20.2 Ground water testing results at Gaocheng village (1)

Sample location		Testing item							
		PH	Permanganate mg/L	Sulphate mg/L	Volatile phenol mg/L	Ammonia nitrogen mg/L	Fecal coliform number/L	Chromium mg/L	Mg mg/L
Gaocheng	1st	7.5	0.5	<0.02	<0.0003	<0.02	790	<0.004	<0.010
	2nd	7.4	0.6	<0.02	<0.0003	<0.02	790	<0.004	<0.010
Gaocheng	1st	7.5	0.6	<0.02	<0.0003	<0.02	700	<0.004	<0.010
	2nd	7.5	0.7	<0.02	<0.0003	<0.02	490	<0.004	<0.010
Gaocheng	1st	7.4	0.6	<0.02	<0.0003	<0.02	780	<0.004	<0.010
	2nd	7.4	0.6	<0.02	<0.0003	<0.02	800	<0.004	<0.010

Table 20.3 Ground water testing results at Gaocheng village (2)

Sample location		Testing item								
		Pb mg/L	Cd mg/L	Cu mg/L	As mg/L	Hg mg/L	Fe mg/L	Zn mg/L	Ag mg/L	Ni mg/L
Gaocheng village	1st	<0.003	0.0016	<0.050	<0.0005	<0.00005	<0.030	0.120	<0.0025	<0.005
	2nd	<0.003	0.0013	<0.050	<0.0005	<0.00005	<0.030	0.122	<0.0025	<0.005
Gaocheng village	1st	<0.003	0.0018	<0.050	<0.0005	<0.00005	<0.030	0.121	<0.0025	<0.005
	2nd	<0.003	0.0016	<0.050	<0.0005	<0.00005	<0.030	0.117	<0.0025	<0.005
Gaocheng village	1st	<0.003	0.0017	<0.050	<0.0005	<0.00005	<0.030	0.118	<0.0025	<0.005
	2nd	<0.003	0.0014	<0.050	<0.0005	<0.00005	<0.030	0.117	<0.0025	<0.005

20.4.4 Waste water

There are three sources of waste water identified at the GC project: mining activities, mineral processing and domestic sewage. Mine water is pumped from the underground sumps to the waste water treatment station. Treatment is primarily de-sedimentation and lime addition. Once the water reaches the required standard it is used for forestry and agriculture irrigation or discharged into Hashui Creek. Process water is maintained in a closed circuit and is not discharged into the environment. After the treatment of the sewage water at the sewage treatment station, and testing indicates it has reached the required standard, it is released into the environment.

Table 20.4 shows an example of the monthly underground monitoring results.

Table 20.4 Waste water monitoring results. Guangzhou Najia Testing Technology Ltd. Report No. GZMJIA20170176

Sample type	Waste water		Date analyzed	28 December 2017
Sampled date	28 December 2017		Sample collectors	Zhong Guangyue Xiao Han
Sample status	Colorless, odorless, no floating oil			
Sample location	Underground water discharge			
Monitoring item	Value	Unit	Remarks	
As	8.2	mg/L		
Pb	14.0	µg/L		
Zn	ND		ND - not detected	
Hg	ND		ND - not detected	
Ag	ND		ND - not detected	
Cd	0.9	µg/L		
Cr	ND		ND - not detected	
Cu	7.0	µg/L		
pH	7.52			
Floating particles	18	mg/L		
Oil	0.04	mg/L		
COD	15.6	mg/L		

The GC TMFs under-drainage and return water collection system comprises a pond from which water is directly pumped back to the mill for recycling or to the water treatment system. This TMF decant and filtration system provides a mechanism for reusing recycled water. This existing collection pond is designed to overflow into a second containment / seepage dam. The collected tailings water from the TMF in this dam is pumped back through a pipe to the processing plant for reuse. No tailings water is discharged to the public water body.

Table 20.5 shows an example of tailings water monitoring results.

Table 20.5 Tailing water monitoring results – Guangzhou Najia Testing Technology Ltd. Report No. NJA170717001

Sample type	Tailings water		Date analyzed	27 – 28 July 2017
Sampled date	27 July 2017		Sample collectors	Chen Qiuyang Xiao Han
Sample status	Colorless, odorless, obvious odor and smell			
Sample location	Tailings water reuse pond			
Monitoring item	Value	Unit	Remarks	
As	ND	mg/L	ND – not detected	
Pb	0.43	mg/L		
Zn	0.13	mg/L		
Hg	ND	µg/L	ND – not detected	
Cd	ND	mg/L	ND – not detected	
Cr	ND	mg/L	ND – not detected	
Cu	ND	mg/L	ND – not detected	
Sulphide	0.009	mg/L		
Floating particles	57	mg/L		
PH	11.05			
COD	374	mg/L		

20.4.5 Gas emission monitoring

Gas and floating particles are monitored regularly by the contractor, Guangzhou Najia Testing Technology Ltd. Table 20.6 and Table 20.7 show examples of exhaust gas monitoring results at the Mill Screening Workshop and Crushing Workshop respectively.

Table 20.6 Exhaust gas monitoring results – Screening workshop. Guangzhou Najia Testing Technology Ltd. Report No. GZNJIA20170176

Sample type	Exhaust gas		Sample collectors		Zhong Guangyue Xiao Han	
Sampling date	28 December 2017		Analyzed date		29 December 2017	
Facility	Dedust Bag		Monitoring environment		Fine. Temperature 19.8°C. Barometer: 101.7 kPa	
Sample point	FQ – fed02. Screening workshop exhaust gas discharge.					
Monitoring item	Content, mg/m³				Average	Discharge rate, kg/h
	1	2	3	4		
Particle	7.98	8.14	8.29	-	8.14	0.110
Parameter	Chimney height, m	Diameter, m	Gas temperature, °C	Gas velocity, m/s	Gas quantity, Q_{snd}, m³/h	
	15	∅0.6	26	15.3	13,551	

Table 20.7 Exhaust gas monitoring results – Crushing workshop. Guangzhou Najia Testing Technology Ltd. Report No. GZNJIA20170176

Sample type	Exhaust gas		Sample collectors		Zhong Guangyue Xiao Han	
Sampling date	28 December 2017		Analyzed date		29 December 2017	
Facility	Dedust Bag		Monitoring environment		Fine. Temperature 19.8°C. Barometer: 101.7 kPa	
Sample point	FQ – fed01. Crashing workshop exhaust gas discharge.					
Monitoring item	Content, mg/m³				Average	Discharge rate, kg/h
	1	2	3	4		
Particle	5.12	5.15	5.00	-	5.09	0.085
Parameter	Chimney height, m	Diameter, m	Gas temperature, °C	Gas velocity, m/s	Gas quantity, Q_{sd}, m³/h	
	15	Φ0.7	27	13.8	16,653	

The above results show gas emissions measured comply with the Comprehensive Emission Standard of Atmospheric Pollutants (GB16297-1996).

20.4.6 Noise monitoring

Noise is regularly measured at the East, South, West and North boundaries. Table 20.8 shows example noise monitoring results. All the noise levels are below the Standard limits.

Table 20.8 Noise monitoring results - Guangzhou Najia Testing Technology Ltd. Report No. GZNJIA20170176

Monitoring condition: Fine. Wind velocity: 1.4 m/s. (no rain, no storm, wind velocity <5 m/s)					
Point No	Monitoring point	Period	Result [unit: LeqdB(A)]		Standard limit, LeqdB(A)
			28 Dec 2017	-	
N1	East boundary	Day	53.0	-	65
		Night	43.6	-	55
N2	South boundary	Day	60.4	-	65
		Night	42.4	-	55
N3	West boundary	Day	55.9	-	65
		Night	45.2	-	55
N4	North boundary	Day	56.3	-	65
		Night	44.1	-	55

20.4.7 Soil testing

Soil samples from three nearby villages were collected and tested on 25 December 2014. Table 20.9 shows the testing result.

Table 20.9 Soil testing result

Sample location	Testing item							
	PH	Hg mg/Kg	As mg/Kg	Pb mg/Kg	Cd mg/Kg	Ag mg/Kg	Cu mg/Kg	Zn mg/Kg
Gaocun farm	6.2	0.162	29.2	68.9	0.24	0.94	30.2	106
Youcun farm	5.5	0.097	27.9	55.6	0.21	0.99	24.3	92.1
Fengmucun farm	5.3	0.136	6.0	47.8	0.25	0.24	10.8	93.4

20.5 Permitting requirements

Silvercorp has completed the following permitting and contracting requirements to receive approval to extract ore from the GC Mine:

- Silvercorp obtained a Notice of Approval to start the process of the Application for Mining Permit from the Ministry of Land and Resources (MOLAR) in BeiYing on a designated mining area. Silvercorp received the Notice of Approval from MOLAR in 2008.
- The Resource Utilization Plan (RUP) Report on the GC project prepared by the Guangdong Institute of Metallurgical Industry was reviewed by a MOLAR design review organization, the China Non-Ferrous Metal Association, in 2008.
- The Health and Safety section of the RUP Report was reviewed by the Guangdong Provincial Safety Production Bureau in 2008. Both reviews indicated that the report satisfied the requirement for the mining permit application.
- An Environmental Assessment Report was completed in March 2009 and passed a review by an expert panel appointed by the Environmental Protection Bureau of Guangdong Province and by the local community.
- A Geological Hazards Assessment Report and Soil Conservation Plan Report prepared by a qualified geo-engineering firm, was reviewed and filed with Ministry of Land and Resources.
- A Geological Environment Protection and Rehabilitation and Reclamation Measure Report, prepared by a qualified geo-engineering firm, was reviewed and filed with the Ministry of Land and Resources.
- A Land Reclamation Measure Report, prepared by a qualified engineering firm, was reviewed and filed with the Ministry of Land and Resources.
- An Environmental Permit for the GC Silver-Lead-Zinc Project was issued by the Department of Environmental Protection of Guangdong Province in June 2010.
- A mining permit application for the GC Silver-Lead-Zinc Project was submitted to MOLAR in August 2010.
- A mining permit for the GC Mine was issued by the Ministry of Land and Resources of China. The GC mining permit has a term of 30 years and covers the entire 5.5237 square kilometre area of the GC project. The permit was issued on the terms applied for and allows for the operation of an underground mine to produce silver, lead and zinc ores.
- A qualified Chinese engineering firm finalized the mine design of a 1,600 tonne per day mechanized underground mine, a flotation mill, and a dry stack tailings facility, which plan was reviewed and approved by the relevant government agents.
- Land usage and acquisition of land for the GC Mine and milling sites was completed.
- A qualified mining development contractor was hired to build the mine.
- The same contractor who built Silvercorp's two mills (3,000 t/d) at the Ying Mining District was hired to construct a 1,600 t/d capacity flotation mill capable of producing silver-lead, zinc, pyrite flotation concentrates, and a tin gravity concentrate.
- An explosive permit was issued, and an explosive magazine was built following the requirement of the Bureau of Public Security.

- Completion of a review of the health and safety production measures in the mine design by the Guangdong Provincial Safety Production Bureau, after which review documentation was be filed with the Guangdong Provincial Safety Production Bureau.
- A "Safety Production Permit" was issued in 2015 by the Guangdong Provincial Safety Production Bureau to satisfy that the construction of the mine, mill and tailings facility for the Stage I of mine construction (Commercial Production) was done appropriately. The Stage II expansion was completed in late 2017 and the "Safety Production Permit" was renewed subsequently.
- The Guangdong Environmental Bureau also conducted an inspection of the tailings facility, flotation mill, and other environmental engineering works upon completion of the Stage II expansion. An environmental permit to operate was issued.

20.6 Social and community interaction

The nearest significant community to the GC project is the Gaocun Township, which is approximately 5 km from the mining area. Both Yunfu City and Yunan County are about 30 km from the GC Mine. Residents in the project area hold a positive attitude to the development of the project. Public participation methods for this project are information disclosure, inquiry form-sending, and promotion and improvement of reclamation consciousness. There is a mechanism to communicate to local government regularly.

Utilized at the site are low-noise machinery and equipment, measures to minimize vibration, noise-proofing, noise reduction on the crusher, ball crusher, floater to ensure that the noise level of the mining area and the plant boundary meet the requirements of Class III function area limitation of emission standard for industrial enterprises noise at boundary (GB 12348-2008). The noise level inside the mine area and nearby inhabitant areas are intended to meet the requirements of Class II function area standard.

Silvercorp also employs several local contractors to carry out construction and maintenance work.

Between 2013 and 2016, Silvercorp sponsored several sections of local roads.

AMC understands that there are no records of public complaints in relation to Silvercorp's Gaocheng Property operations.

20.6.1 Cultural minorities and heritages

There are no cultural minority groups within the general project area. The cultural make-up of the broader Yunan County is predominantly Han Chinese. AMC understands that there are no records of cultural heritage sites located within or near the Gaocheng Property.

20.6.2 Relationships with local government

Silvercorp has indicated that it has close relationships with the local Yunan County and Yunfu City.

20.6.3 Labour practices

Silvercorp's production activities are in compliance with Chinese labour regulations. Formal contracts are signed for all the full time employees with what AMC understands are wages well above minimum. The company provides annual medical surveillance and checks are conducted for its employees before, during and after their employment with the Company. The Company does not use child or under-aged labour.

20.7 Remediation and reclamation

Remediation and reclamation plans have been discussed in the above text. AMC understands that Silvercorp has spent \$3.0M acquiring land for the project and has also posted \$200,000 to the Yunan County Government as bond for reclamation.

Table 20.10 shows RMB '000 spending on remediation and reclamation project from 2012 to 2017.

Table 20.10 Expenditures on reclamation and remediation from 2012 to 2017 ('000 RMB)

Year	2012	2013	2014	2015	2016	2017	Sub total
Environmental Protection		285.26	51.67	89.33	61.87	129.69	617.81
EIA							
Soil & Water Conservation				452.32	51.89		504.20
Environmental Equipment		166.05		96.79	10.00	164.15	436.99
Tailing Dam		6,168.32	68.70				6,237.02
Compensation for land acquisition		34,240.81				322.54	34,563.35
Totals		40,860.44	120.37	638.44	123.76	616.38	42,359.39

20.8 Site closure plan

Mine closure will comply with Chinese National requirements. These comprise Article 21 (Closure Requirements) of the Mineral Resources Law (1996), and Articles 33 and 34 of the Rules of Implementation Procedures of the Mineral Resources Law of the People's Republic of China (2006).

The site closure planning process will include the following components:

- Identify all site closure stakeholders (e.g. government, employees, community, etc.).
- Undertake stakeholder consultation to develop agreed site closure criteria and post operational land use.
- Maintain records of stakeholder consultation.
- Establish a site rehabilitation objective in line with the agreed post operational land use.
- Describe / define the site closure liabilities (i.e. determined against agreed closure criteria).
- Establish site closure management strategies and cost estimates (i.e. to address / reduce site closure liabilities).
- Establish a financial accrual process for site closure.
- Describe the post site closure monitoring activities / program (i.e. to demonstrate compliance with the rehabilitation objective / closure criteria).

Based on Chinese National requirements, a site decommissioning plan will be produced at least one year before mine closure. Site rehabilitation and closure cost estimates will be made in the site closure plan.

21 Capital and operating costs

21.1 Key cost parameters

Silvercorp utilizes contract labour for mining at Gaocheng on a rate per tonne or a rate per metre basis. The contract includes all labour, all fixed and mobile equipment, materials, and consumables, including fuel and explosives, which are purchased through the company. Ground support consumables such as timber and power are the responsibility of the company.

The costs indicated below are summarized from the FY2019 Gaocheng budget. Cost estimates are in U.S. dollars and assume an exchange rate of 6.5 RMB to US\$1.

The budget is based on mining and milling 250,000 tonnes of ore, of which 97% would be by shrinkage and 3% by resuing. Other major operational requirements budgeted are waste development at 4,479 m, exploration tunnelling at 11,060 m, and drilling at 30,000 m. Sustaining development of 673 m is also budgeted.

21.2 Capital costs

All major infrastructure for operation of the Gaocheng mine is in place, including that for the potential production rate increase to 1,600 tpd.

21.2.1 Sustaining capital

Gaocheng sustaining capital costs are budgeted for mine development tunnelling and for property, plant and equipment. Table 21.1 summarizes the FY2019 estimate.

Table 21.1 Gaocheng sustaining capital budget FY2019

Sustaining capital	US\$
Mine development tunnelling cost	183,460
Cost per metre	273
PPE investment / replacement	616,540
Cost per tonne of ore mined & milled	2.61
Total sustaining capital	810,000
Cost per tonne of ore mined	3.24

21.3 Operating costs

Operating costs budgeted for FY2019 are summarized below in Table 21.2. AMC has also reviewed operating cost summaries for the financial years since the start of commercial operations and considers that the FY2019 budgeted costs are reasonable.

Mining operating costs are categorized by direct mining (shrinkage or resuing), waste development, exploration tunnelling, drilling, and common costs.

Other budgeted operation costs are for milling, general and administrative items, and government fee, Mineral Resources tax, and other taxes.

Table 21.2 Gaocheng operating cost budget 2019*

Gaocheng operating costs	US\$ or US\$/t
Direct mining costs	
Resuing cost	
Contractor cost	110,682
Mining materials	8,596
Utility	8,341
Subtotal	127,620
Per tonne cost over resuing ore	17.1
Shrinkage cost	
Contractor cost	2,595,255
Mining materials	99,677
Utility	178,998
Others	20,900
Subtotal	2,894,831
Per tonne costs over shrinkage ore	11.66
Waste development costs	
Tunneling cost	1,155,000
Cost per metre	264
Cost per tonne of ore mined	4.62
Exploration tunneling costs	
Exploration tunneling costs	2,945,000
Cost per tonne of ore mined	11.78
Drilling cost	1,015,000
Cost per metre	34.62
Cost per tonne of ore mined	4.06
Common costs	
Equipment maintenance	851,077
Mine administration	33,877
Labour Cost	1,620,840
Subtotal	2,382,549
Cost per tonne of ore mined	9.53
Total mining cost	10,520,000
Cost per tonne of ore mined	42.08
Milling costs	
Milling cost	4,195,000
Cost per tonne of ore milled	16.78
G&A	
G&A	1,915,000
Cost per tonne of ore mined and milled	7.66
Gov. fee, mineral rsrcs tax, & other taxes	
Government fee and other taxes	1,857,500
Cost per tonne of ore milled	7.43
Total operating costs	18,487,500
Total operating cost/t ore mined & milled	73.95

*For 2019 budgeting, assumed production was 250,000 t and includes 6,882 t of exploration tunnelling material anticipated to be ore.

Contractor costs are the major component of the mining cost. The principal components of the milling costs are utilities (power and water), consumables (grinding steel and reagents), and labour.

G&A costs include allowances for tailings management and environmental costs.

The government fee and taxes category includes Mineral Resources tax at 3% of sales.

AMC considers the operating costs to be reasonable relative to the methods and technology used and to the scale of the Gaocheng operation.

22 Economic analysis

22.1 Introduction

Although Silvercorp is a producing issuer and, therefore, does not require an economic analysis for the purposes of this report, AMC believes it is reasonable to include a summary-level analysis to illustrate the potential economic impact relative to the latest Mineral Reserve estimation and to the associated production schedule.

The Gaocheng mine has been in commercial production for four years. From FY2019 onwards, a 12-year LOM is envisaged for the resource as currently understood, with average silver equivalent grades projected to be of the order of 335 g/t for the first eight years and then to fall to an average of 240 g/t for the remainder of the mine life. Operating and capital costs are anticipated to be reasonable. For the summary economic assessment, AMC has largely used FY2019 budget cost projections, and the same metal prices as in the Mineral Reserve estimation, namely:

- Silver US\$19.0/oz
- Lead US\$1.00/lb
- Zinc US\$1.25/lb

Some alternative metal price scenarios are considered as part of the sensitivity analysis.

A provision for government fees and mineral resource taxes at 5% of net revenue is made in the summary economic analysis, together with an exchange rate assumption of 1US\$ = 6.50 RMB.

22.2 Annual production schedule

The LOM ore production schedule by mine is shown in Table 22.1.

AMC notes that, for the average LOM production grades and metal prices as assumed, the projected respective value contributions by metal are:

- Zinc – 45%
- Silver – 35%
- Lead – 20%

Table 22.1 Gaocheng LOM production schedule

Financial year / quarter	Ore tonnes	Mined ore grade				Planned metals		
		AgEq (g/t)	Ag (g/t)	Pb (%)	Zn (%)	Ag (t)	Pb (t)	Zn (t)
FY2018Q4	30,632	298	96	1.15	3.46	2.94	352	1,059
FY2018-total	30,632	298	96	1.15	3.46	3	352	1,059
FY2019Q1	59,940	296	96	1.31	3.26	5.76	783	1,953
FY2019Q2	64,444	300	96	1.22	3.44	6.19	785	2,214
FY2019Q3	71,445	298	104	1.36	3.06	7.44	971	2,185
FY2019Q4	47,288	322	136	1.42	2.82	6.42	672	1,333
FY2019-total*	243,118	303	106	1.32	3.16	26	3,210	7,686
FY2020Q1	68,007	320	105	1.56	3.32	7.17	1,063	2,258
FY2020Q2	65,856	346	110	2.06	3.30	7.26	1,358	2,171
FY2020Q3	85,508	348	113	1.91	3.46	9.64	1,632	2,960
FY2020Q4	63,420	339	139	1.61	2.95	8.80	1,021	1,873
FY2020-total	282,790	339	116	1.79	3.28	33	5,073	9,262
FY2021	294,124	351	132	1.65	3.36	38.77	4,850	9,873
FY2022	314,030	335	110	1.90	3.23	34.50	5,960	10,157
FY2023	329,479	321	102	1.57	3.41	33.70	5,166	11,234
FY2024	332,924	317	104	1.57	3.30	34.51	5,227	10,975
FY2025	335,778	303	95	1.62	3.12	31.87	5,441	10,475
FY2026	321,470	289	107	1.26	2.89	34.45	4,058	9,298
FY2027	323,713	255	79	1.12	2.88	25.60	3,628	9,338
FY2028	299,861	247	75	1.10	2.81	22.59	3,300	8,425
FY2029	251,114	208	56	1.00	2.47	14.09	2,503	6,204
FY2030	204,791	206	58	0.96	2.42	11.84	1,963	4,952
Total	3,563,826	293	96	1.42	3.06	344	50,732	108,938

*Excludes 6,882 of exploration tunnelling material anticipated to be ore in 2019 budgeting.

22.3 Cash flow forecast

Based on the LOM production profile and the metal price and other assumptions shown above, simple pre-tax and post-tax cashflow projections have been generated as presented in Table 22.2.

A base case NPV at 8% discount rate of \$160M (pre-tax), \$120M (post-tax) is projected.

Table 22.2 Gaocheng mine cash flow projection

Item	Unit / Yr	2018 Q4	2019	2020	2021	2022	2023	2024	2025	2026	2027	2028	2029	2030	Total
Silver price	US \$/oz	19	19	19	19	19	19	19	19	19	19	19	19	19	19
Lead price (US\$1.00/lb)	US \$/t	2,205	2,205	2,205	2,205	2,205	2,205	2,205	2,205	2,205	2,205	2,205	2,205	2,205	2,205
Zinc Price (US\$1.25/lb)	US \$/t	2,756	2,756	2,756	2,756	2,756	2,756	2,756	2,756	2,756	2,756	2,756	2,756	2,756	2,756
Planned metal – Ag	t	2.94	25.81	32.87	38.77	34.50	33.70	34.51	31.87	34.45	25.60	22.59	14.09	11.84	344
Planned metal – Pb	t	352	3,210	5,073	4,850	5,960	5,166	5,227	5,441	4,058	3,628	3,300	2,503	1,963	50,732
Planned metal – Zn	t	1,059	7,686	9,262	9,873	10,157	11,234	10,975	10,475	9,298	9,338	8,425	6,204	4,952	108,938
Silver revenue (gross)	US\$M	1.80	15.76	20.08	23.68	21.07	20.58	21.08	19.47	21.04	15.64	13.80	8.61	7.23	210
Lead revenue (gross)	US\$M	0.78	7.08	11.18	10.69	13.14	11.39	11.52	12.00	8.95	8.00	7.28	5.52	4.33	112
Zinc revenue (gross)	US\$M	2.92	21.18	25.52	27.21	27.99	30.96	30.25	28.87	25.62	25.73	23.22	17.10	13.65	300
Total gross revenue	US\$M	5.49	44.02	56.79	61.58	62.20	62.93	62.85	60.33	55.61	49.37	44.29	31.22	25.21	622
Silver net % payable	%	85%	85%	85%	85%	85%	85%	85%	85%	85%	85%	85%	85%	85%	85%
Lead net % payable	%	94%	94%	94%	94%	94%	94%	94%	94%	94%	94%	94%	94%	94%	94%
Zinc net % payable	%	76%	76%	76%	76%	76%	76%	76%	76%	76%	76%	76%	76%	76%	76%
Silver revenue (net)	US\$M	1.53	13.40	17.07	20.13	17.91	17.50	17.92	16.55	17.89	13.29	11.73	7.32	6.15	178
Lead revenue (net)	US\$M	0.73	6.65	10.51	10.05	12.35	10.71	10.83	11.28	8.41	7.52	6.84	5.19	4.07	105
Zinc revenue (net)	US\$M	2.22	16.10	19.40	20.68	21.27	23.53	22.99	21.94	19.47	19.56	17.65	12.99	10.37	228
Total net revenue	US\$M	4.48	36.15	46.98	50.86	51.54	51.73	51.74	49.76	45.77	40.37	36.21	25.50	20.59	512
Operating costs															
Mining	US \$/t	42.08	42.08	42.08	42.08	42.08	42.08	42.08	42.08	42.08	42.08	42.08	42.08	42.08	42
Milling	US \$/t	16.78	16.78	16.78	16.78	16.78	16.78	16.78	16.78	16.78	16.78	16.78	16.78	16.78	17
General & administration	US \$/t	7.66	7.66	7.66	7.66	7.66	7.66	7.66	7.66	7.66	7.66	7.66	7.66	7.66	8
Gov. fees & taxes	US \$/t	7.30	7.43	8.31	8.65	8.21	7.85	7.77	7.41	7.12	6.24	6.04	5.08	5.03	7
Total operating cost	US\$M	2.26	17.98*	21.16	22.11	23.47	24.51	24.73	24.83	23.67	23.55	21.76	17.98	14.65	263
Sustaining capital costs															
Mining development	US\$M	0.02	0.17	0.20	0.21	0.23	0.24	0.24	0.24	0.23	0.23	0.22	0.18	0.15	3
PPE investment / replacement	US\$M	0.08	0.64	0.74	0.77	0.82	0.86	0.87	0.88	0.84	0.85	0.78	0.66	0.54	9
Total sustaining capital cost	US\$M	0.10	0.81	0.94	0.98	1.05	1.10	1.11	1.12	1.07	1.08	1.00	0.84	0.68	12
Undiscounted pre-tax cash flow	US\$M	2.11	17.36	24.87	27.77	27.02	26.13	25.90	23.82	21.03	15.74	13.46	6.68	5.25	237
Undiscounted post-tax cash flow @ 25% tax rate	US\$M	1.58	13.02	18.66	20.83	20.27	19.60	19.42	17.86	15.77	11.80	10.09	5.01	3.94	178
Pre-tax NPV @ 8%	US\$M	160													
Post-tax NPV @ 8%	US\$M	120													

*2019 cost/t values as per Table 21.2 – tonnage as per LOM.

22.4 Sensitivity analysis

Table 22.3 shows impact on pre- and post-tax NPV_{8%} of a 20% deviation in individual metal prices, operating cost and capital cost. Most sensitivity is seen in operating cost, followed closely by zinc price, then silver price. The NPV_{8%} is moderately sensitive to lead price and, as would be anticipated for a fully operating mine, only slightly sensitive to sustaining capital cost.

An individual sensitivity case is also indicated in Table 22.3, with projected pre- and post-tax NPV_{8%} values shown for metal values prevalent at the time of writing of this report, namely: Ag – \$16.75/troy ounce, Pb – \$1.14/lb, Zn – \$1.45/lb.

Table 22.3 Gaocheng mine sensitivity analysis

Item	Variant	Unit	Pre-tax NPV (US\$M)	Post-tax NPV (US\$M)
Base case (post-tax NPV @ 8% discount rate)	-	-	160	120
Silver price – 20% decrease	15.20	US\$/lb	137	103
Lead price - 20% decrease	0.80	US\$/lb	147	110
Zinc price - 20% decrease	1.00	US\$/oz	132	99
Opex increase	20	%	126	95
Capex increase	20	%	158	119
Silver price – 20% increase	22.80	US\$/lb	182	137
Lead price - 20% increase	1.20	US\$/lb	173	130
Zinc price - 20% increase	1.50	US\$/oz	188	141
Opex decrease	20	%	193	145
Capex decrease	20	%	161	121
Current metal prices: Ag \$16.75/lb, Pb \$1.10/lb, Zn \$1.45/lb	Various		176	132

23 Adjacent properties

The GC project is located within the Dagenshan mineralization field featuring tungsten (W), tin (Sn), gold (Au), silver (Ag), lead (Pb), zinc (Zn) mineralization, Figure 23.1. The field is characterized by five "nested" zonations. From the centre outward, the mineralization zones are W, Sn, Sn-Pb-Zn, Ag-Pb-Zn, and Au. The following are a list of deposits that have been discovered and mined within the field.

Dajinshan Tungsten Deposit. The deposit is located in the centre of the Dagenshan field.

Jiuquling Tin Deposit. The deposit is a quartz vein type and surrounds the tungsten mineralization zone. It is reported that the Jiuquling deposit has been developed and is production, however detailed information such as grade, deposit size, tonnage; metal recovery, etc. are not available at this time.

Jianshan Tin-Lead-Zinc-Silver Deposit. The deposit is located in the tin-lead-zinc mineralization zone. It is sedimentary type of deposit.

Yunfu Pyrite Deposit. The Yunfu pyrite mine is an open pit mine located 4.5 km northwest of the city of Yunfu. Mine production began in 1988.

Figure 23.1 illustrates the general geological understanding of properties adjacent to the GC Mine. AMC is not aware of any immediate adjacent properties that would directly affect the interpretation or evaluation of the mineralization and anomalies found on the GC project property.

Figure 23.1 Zonation of mineralization in the Dagenshan mineralization field

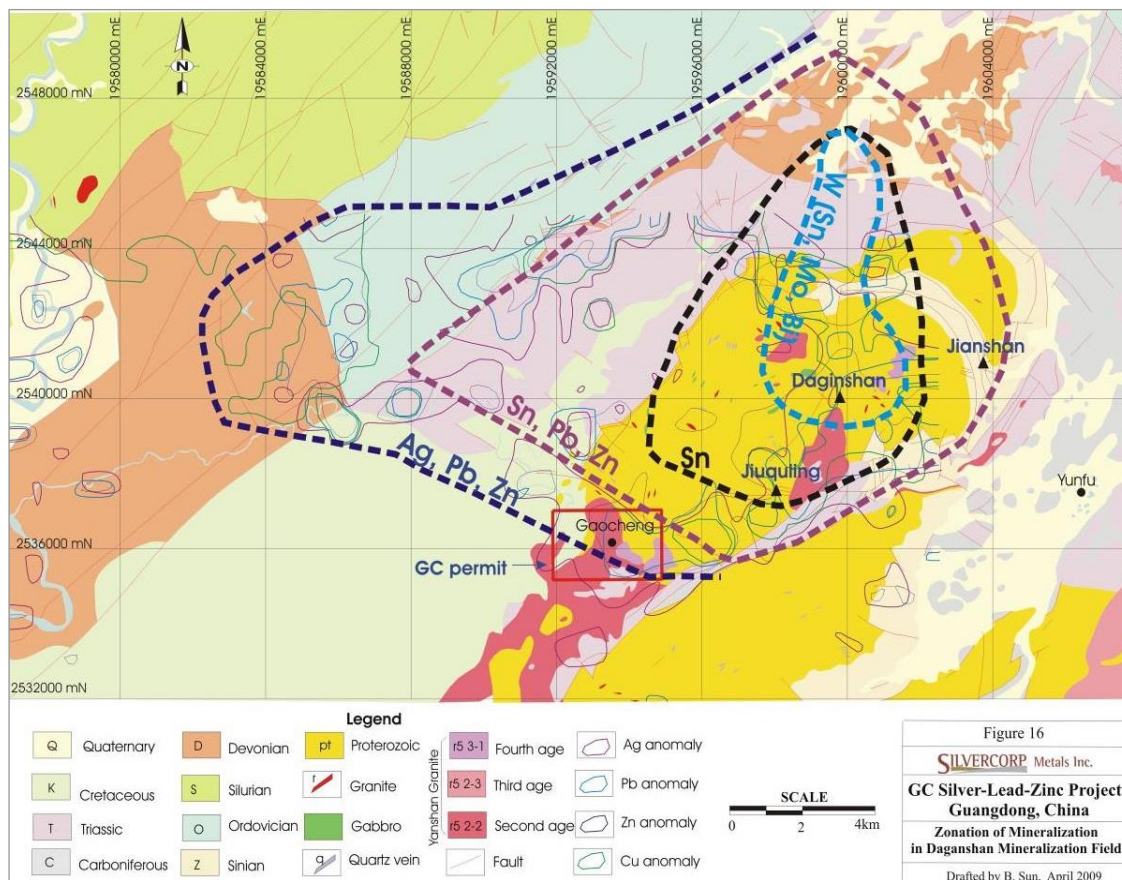

24 Other relevant data and information

AMC considers that there is no additional information or explanation required to make the Technical Report understandable and not misleading.

25 Interpretation and conclusions

Polymetallic mineralization at the GC project comprises over 80 distinct veins, ranging in thickness from a few centimetres to several metres, with a general east-west orientation and dipping generally south at 60° – 80°. The Mineral Resource estimates described in the report were prepared by Silvercorp using Micromine software and reviewed, classified and signed off by Ms D. Nussipakynova, P.Geo. of AMC, who is a Qualified Person for the purposes of the Technical Report.

Using a 100 g/t silver equivalent (AgEq) cut-off grade, Measured and Indicated Resources (inclusive of Mineral Reserves) are estimated at 6.37 million tonnes grading 96 g/t silver (Ag), 1.3% lead (Pb), and 2.9% zinc (Zn); and Inferred Mineral Resources are estimated at 7.48 million tonnes grading 107 g/t Ag, 1.2% Pb, and 2.6% Zn.

Compared to the previous estimate of Mineral Resources (Technical Report effective date 23 January 2012 – the '2012 Technical Report') Measured and Indicated Resources have decreased by 16%, which is a combination of mining depletion and change in classification method. Inferred Mineral Resources have decreased by 6%. In the Measured category the silver grade has decreased by 56% and lead and zinc grades have decreased by 1% and 3% respectively. In the Indicated category silver grades have increased by 18%, and lead and zinc grades have decreased by 7% and 12% respectively. In the Inferred category, grades have decreased for silver, lead, and zinc by 13%, 16%, and 2% respectively.

The results of the underground drilling program at GC show that vein structures are still open at depth.

Silvercorp has implemented industry standard practises for sample preparation, security and analysis. This has included common industry QA/QC procedures to monitor the quality of the assay database, including inserting Certified Reference Material (CRM) samples, blank samples and coarse (uncrushed) sample duplicates into sample batches on a predetermined frequency basis. Umpire check duplicates samples have been submitted to check laboratories to confirm analytical accuracy.

AMC's review of Silvercorp's QA/QC procedures has highlighted a number of issues that require further investigation and improvement. AMC and Silvercorp have discussed these issues and agreed on a process to address and improve QA/QC, the recommendations for which are itemized in Section 26. AMC does not consider these issues to have a material impact on the global Mineral Resources and Mineral Reserve estimates but believes that there could be material impacts on a local scale. Overall, it considers the assay database to be acceptable for Mineral Resource estimation.

Mineral Reserves have been estimated using a full breakeven cut-off grade of 180 g/t AgEq for shrinkage stoping (245 g/t AgEq for the projected smaller amount of resuing), based on a mine design and plan prepared by Silvercorp engineers and reviewed by Mr H. Smith, P.Eng. of AMC, who is a Qualified Person for the purposes of the Technical Report. Total Proven and Probable Reserves are 3.56 million tonnes grading 96 g/t silver, 1.4% lead, and 3.1% zinc, containing 11 million ounces silver, 112 million pounds lead, and 240 million pounds zinc.

Metal prices used in determining cut-off grades for both Mineral Resources and Mineral Reserves are: silver - \$19/troy ounce; lead - \$1.00/lb; zinc - \$1.25/lb. An exchange rate of RMB 6.5 : US\$1 and mining costs of \$37/t for shrinkage and \$65/t for resuing have been assumed. Metallurgical recovery assumptions are: silver – 77%; lead – 86%, zinc – 83%.

In comparison with the Mineral Reserve estimate in the 2012 Technical Report, there is a 264% increase in Proven Mineral Reserve tonnes and a 56% decrease in Probable Mineral Reserve tonnes,

resulting in a decrease in total Mineral Reserve tonnes of 25% (1,186,000 tonnes). Silvercorp received a mining permit in December 2010. From the start of commercial operations at Gaocheng in 2014 through to 31 December 2017, 988,000 tonnes have been mined at average head grades of 98 g/t silver, 1.5% lead, and 2.7% zinc.

The predominant shrinkage mining method uses the blasted ore as the working platform for each stope lift. The ore is removed on completion of stope mining leaving an empty void. There is potential to opportunistically dispose of development waste into these voids but current mine plans do not include this approach. The rescue method uses blasted waste from the footwall as the working platform for each stope lift. The waste remains in the stope at completion of stope mining. Some hand sorting of ore from waste is conducted.

The rock mass condition is categorized as Fair to Good. AMC's previous assessment anticipated that the vein and host rocks in the mine area would generally be competent and require minimal ground support. This has largely been confirmed in operations, with most areas deemed to require little or no support. Where Poor ground conditions have been encountered, ground support is provided, with a range of strategies available depending on the local situation.

Based on Proven and Probable Reserves only, the GC mine is a viable operation with a projected Life of Mine (LOM) of 12 years through to 2030, with an average annual production rate of approximately 300,000 tonnes, and with average silver equivalent grades of the order of 335 g/t for the first eight years and then 240 g/t for the remainder of the mine life. GC also has the potential to extend the LOM beyond 2030, via conversion of existing Mineral Resources to Mineral Reserves, and further exploration and development.

Since the start of trial operations in 2013 and commercial production in 2014 (FY2015), lead and zinc concentrates have been produced in commercial quantities at the GC processing plant. Small amounts of tin concentrate and sulphur have also been produced but these quantities have not been significant enough to be material to mine economics. In all sections of the plant, space / capacity has been allocated for an expansion to 1,600 tpd, but such expansion is not contemplated at this time.

Sales contracts are in place for the lead concentrates with Shandong Humon Smelting Co. Ltd., and for the zinc concentrate with Chenzhou Qiantai Industrial Co. Ltd. and Henan Yuguang Zinc Industry Co. Ltd. All contracts have an effective period of one year, with key elements of the contracts subject to change based on market conditions when monthly supplemental agreements to the annual contracts are negotiated. All contracts have freight and related expenses to be paid by the customers.

In the 2012 Technical Report, AMC expressed some concerns about potential arsenic (As) levels in concentrates. AMC understands that an acceptable arsenic level in base metal concentrates, without penalty, for the Chinese smelters with which Silvercorp has contracts is of the order of 1.0%, and notes that the GC lead and zinc concentrates are acceptable to those smelters.

All pertinent facilities are in place at the GC site, inclusive of security, accommodation, catering, engineering and administration building, mine dry, mine ventilation, main power sub-station, mine rescue, water supply, compressed air, underground dewatering, sewage treatment, explosives magazines, water treatment plant, maintenance / repair facilities, storage, laboratory, communications, fuel farm, fire prevention, waste rock dump, and TMF.

With respect to waste rock, all such material brought to surface is either used by Silvercorp for construction / maintenance activities or is removed from the site, free of charge, by local persons,

again as construction material. The environmental assessment has indicated that waste rock at the GC mine has no significant acid-generating potential.

The TMF utilizes dry stacking and filling (from bottom to top and stacking by bench to form the embankment) with concurrent rolling and compaction. In the 2012 Technical Report AMC recommended that the TMF safety analysis be re-assessed in accordance with industry practice. The most recent TMF risk assessment report was approved by the Chinese authorities on 14 May 2018 and the TMF Safety Production Certificate was renewed on 4 September 2017. That notwithstanding, AMC has recommended that Silvercorp continues to satisfy itself, as per best industry practice, that all fundamental aspects of the TMF design, construction and operation have been and continue to be satisfactorily addressed. This may include geotechnical drilling of the dam foundation area, as it is AMC's understanding that such activity has not specifically been undertaken.

Silvercorp utilizes contract labour for mining at GC on a rate per tonne or a rate per metre basis. The contract includes all labour, all fixed and mobile equipment, materials, and consumables, including fuel and explosives, which are purchased through the company. Ground support consumables such as timber and power are the responsibility of the company.

The FY2019 budget is based on mining and milling 250,000 tonnes of ore, of which 97% would be by shrinkage and 3% by resuing. Other major operational requirements budgeted are waste development at 4,479 m, exploration tunneling at 11,060 m, and drilling at 30,000 m. Sustaining development of 673 m is also budgeted. Cost estimates are in U.S. dollars and assume an exchange rate of 6.5 RMB to US\$1.

FY2019 sustaining capital is budgeted at \$810,000, which equates to \$3.24 per tonne of ore projected to be mined.

Based on the LOM production forecast and projected mining costs, and assuming long-term metal prices to be the same as those used for cut-off grade determination (silver - \$19/troy ounce; lead - \$1.00/lb; zinc - \$1.25/lb), a simple economic model analysis indicates a pre-tax NPV at 8% discount rate of \$160M (\$120M post-tax). Over the LOM, 45% of the net revenue is projected to come from zinc, 35% from silver, and 20% from lead.

As part of an economic sensitivity assessment, metal prices more in line with those current at the time of writing of this Technical Report (silver - \$16.75/troy ounce, lead - \$1.14/lb, zinc - \$1.45/lb) were used in the simple economic model, resulting in a projected pre-tax NPV at 8% discount rate of \$176 M (\$132 M post-tax). For this scenario, 49% of the net revenue is projected to come from zinc, 29% from silver, and 22% from lead.

26 Recommendations

AMC makes the following recommendations for the GC mine:

AMC's review of Silvercorp's QA/QC procedures has highlighted a number of issues that require further investigation and improvement. AMC and Silvercorp have discussed these issues and agreed on a process to address and improve QA/QC via an overhaul of the CRM program as follows:

- Purchase five additional commercially-produced CRMs, one high grade, two at around the cut-off grade of the deposit and two at around the expected grade of the deposit (note that having CRMs with similar, but slightly different values, reduces the chances of the laboratory recognizing them).
- If Silvercorp intends to keep using GSO-2, require the Institute of Geophysical and Geochemical Exploration to provide the standard deviation data.
- Introduce real-time monitoring of CRM results on a batch by batch basis.
- Re-assay sample batches with two consecutive CRMs occurring outside two standard deviations, or one CRM occurring outside three standard deviations.
- Increase insertion rates to at least 5%.
- Investigate the consistent negative biases apparent in the lead and zinc assays for CDN-FCM-7, to determine if they indicate real negative biases for the corresponding sample batches or arise from the GC lab recognizing the CRMs and assuming incorrect certified values.
- Assay the source of the blank material to ensure its suitability as a blank.
- Substantially reduce Silvercorp's pass / fail criteria on blanks to conform with common industry practice.
- Investigate the very marked differences in performance between the ALS and GC labs and seek reassurance from the GC lab that it is using the blanks in a manner consistent with good industry practice.
- Increase blank insertion rates to at least 4% of samples submitted. Insert blanks immediately after expected high grade mineralization.
- Monitor blanks immediately upon receipt of results and have batches re-analysed if significant contamination is indicated.
- Consider the introduction of crushed duplicates and pulp duplicates (replicates) as part of the GC QA/QC program to improve monitoring of sample preparation and assaying performance.
- Conduct sieve analyses at various stages of sample preparation at the laboratory to ensure optimal parameters are achieved and minimal sampling errors are introduced.
- Increase umpire sample submission rates to around 5% for both drillhole and underground samples.
- Modification of the central database so that assay data be recorded without rounding to accurately reflect the original assay certificates.
- Internally validate the existing sample database to ensure that any other sample prefix issues are addressed.
- Review of database and sample procedures to ensure that sample prefix issues do not reoccur.

There are a number of recommendations with respect to Mineral Resource estimation

- Collect additional bulk density samples to represent various ore types including low grade, medium grade, high grade, and waste material.
- Use of a dynamic anisotropy search or to increase the search radius of the ellipse across the veins, to improve grade continuity within the estimation.

- Continue to use the revised AMC approach to Mineral Resource classification which is based on estimation criteria and manual adjustments where appropriate. This eliminates outliers.
- That future modelling of GC deposit is completed as a single block model as opposed to individual block models for each vein.

Further recommendations in the Technical Report are:

- For bulk density assessment and verification, collect additional samples to represent various mineralization types including low grade, medium grade, high grade and waste material.
- Assess ground conditions on a round by round basis in all development headings (ore and waste) to determine the requirement for ground support. Doing so will help prevent the occurrence of significant failures from backs and walls, which require timely rehabilitation and expose the work force to rock fall hazard.
- Ensure scaling of the development heading on a round by round basis.
- Maintain a focus on dilution and grade control.
- Conduct routine check scaling of all unsupported development at the mine. This process can help identify areas of the mine in which rock mass deterioration is occurring and allow rehabilitation works to be planned.
- Where possible, avoid mining development intersections in fault zones, and design drifts to cross fault zones at right angles (to minimize the exposure length within the drift).
- Assess specific rock mass conditions for critical underground infrastructure, including shafts and chambers, to determine ground support requirements to ensure serviceability of the excavation for the life of mine.
- Ensure that an assessment of crown pillar requirements has been incorporated into the detailed mine design with particular focus on surface pillar requirements in the vicinity of Hashui Creek valley, and any other streams (or drainage paths) that traverse the mine area.
- As part of ongoing operations at the mine, geotechnical and ground support aspects should be continuously reviewed in a formal and recordable manner, bearing in mind previous recommendations, local and mine-wide operating experience in all rock types encountered, any advisable data collection, and also looking to future mining development.
- With respect to the TMF, Silvercorp to continue to satisfy itself, as per best industry practice, that all fundamental aspects of the TMF design, construction and operation have been and continue to be satisfactorily addressed. This may include geotechnical drilling of the dam foundation area, as it is AMC's understanding that such activity has not specifically been undertaken.
- Continue with a focus on safety improvement, including implementation of a policy where the more stringent of either Chinese or Canadian safety standards are employed.
- Place a strong focus on stockpiling and record keeping procedures and ensure that the summation of individual ore car weights by stope and zone is, as far as practicable, fully integrated into the tracking and reconciliation process.
- Undertake periodic mill audits aimed at ensuring optimum process control and mill performance.
- Continue exploration tunnelling and diamond drilling at Gaocheng. The exploration tunnelling is used to upgrade the drill-defined Resources to the Measured category, and the diamond drilling is used to expand and upgrade the previous drill-defined Resources, explore for new mineralized zones within the unexplored portions of vein structures, and test for extensions of the vein structures.

27 References

- AMC Mining Consultants (Canada) Ltd., 2012, NI 43-101 Technical Report on the GC AG-ZN-PB Project in Guangdong Province People's Republic of China, 23 January 2012.
- Anhui Yangzi Mining Co. Ltd., November 2007, The summary of the work at Shimentou project area.
- Barton, N., Lien, and R., Lunde, J., 1974, 'Analysis of Rock Mass Quality and Support Practice in Tunneling and a Guide to Estimating Support Requirements' Geotech Inst. Report. No 54206.
- Guangdong Found Mining Co. Ltd., 2011, Mining Engineering Construction Contract of Gaocheng Lead-Zinc Mine Project, Mine Engineering Contract (GF-2011-0225), 19 March 2011.
- Guangdong Provincial Institute of Geological Survey, April 2005, Geological report about general prospecting on Jianshan-Shimentou Pb-Zn multi-metallic deposit, Yunfu city, Guangdong province.
- Guangdong Provincial Institute of Geological Survey, September 2007, Geological report about detailed prospecting on GC Pb-Zn-Ag deposit, Yunfu city, Guangdong province.
- Hoek, E., Kaiser, P.K., and Bawden, W.F., 1995, 'Support of Underground Excavations in Hard Rock', A. A. Balkema, Rotterdam.
- Hutchinson, D.J., and Diederichs, M.S., 1996, 'Cablebolting in Underground Mines', BiTech Publishers Ltd., British Columbia, Canada.
- Jia, Shouyi and Songqing, Ye, 2003, Mineral Resource Exploration. Geological Publishing.
- Liu, Jinhui, Niu, Lanliang, Xu, Anson, and Wang, Zhaojun (SRK Consulting China Ltd.), April 2008: Technical Report On Gaocheng Ag-Zn-Pb Project and Shimentou Au-Ag-Zn-Pb Project, Guangdong Province, People's Republic of China.
- Mine Engineering Contract, (GF-2011-0225), Guangdong Found Mining Co., Ltd. Mining Engineering Construction Contract of Gaocheng Lead-zinc Mine Project, 19 March 2011.
- Mineral and Dressing Project of Gaocheng Lead-Zinc Ore in Yun'an County, Guangdong Province, Preliminary Design (GD1371CS) Volume 1 Instruction by GMADI, Guangdong Metallurgical & Architectural Design Institute, China, January 2011.
- Mokos P, Molavi M, O'Connor B, Stephenson P, Riles A, Watson O, 2011, NI 43-101 Technical Report on the GC Ag-Zn- Pb project in Guangdong Province, Peoples Republic of China, for Silvercorp Metals Inc., 31 December 2011.
- Silvercorp Metals Inc., 2008, Silvercorp Acquires Significant Silver-Lead-Zinc Resources in Guangdong Province, Southern China. Press Release. http://www.silvercorpmetals.com/news/2008/index.php?&content_id=106, 28 April 2008.
- Silvercorp Metals Inc., 2008, Silvercorp Completes Acquisition of Significant Silver-Lead-Zinc Resources in Guangdong Province, Southern China. Press Release. http://www.silvercorpmetals.com/news/2008/index.php?&content_id=110, 6 June 2008.
- Silvercorp Metals Inc., 2009, Drilling Intersects High-Grade Silver Mineralization in V2 and V6 Veins at the GC Silver-Lead-Zinc Project in Guangdong Province, Southern China. Press Release. http://www.silvercorpmetals.com/news/index.php ?&content_id=180, 8 January 2009.

Silvercorp Metals Inc., 2009, Annual Information Form. Annual Report. http://www.silvercorpmetals.com/_resources/Silvercorp_AIF_rev_SEDAR_opt.pdf, 5 June 2009.

Silvercorp Metals Inc., 2009, Consolidated Financial Statements. Annual Report. http://www.silvercorpmetals.com/_resources/fin/annual/2009_SVM_FS_final.pdf, 3 June 2009.

Silvercorp Metals Inc., 2009, Management's Discussion and Analysis ("MD&A"). Annual Report. http://www.silvercorpmetals.com/_resources/fin/annual/2009_SVM_MDA_final.pdf, 3 June 2009.

28 QP Certificates

CERTIFICATE OF AUTHOR

I, Dinara Nussipakynova, P.Geo., of Vancouver, British Columbia, do hereby certify that:

- 1 I am currently employed as Principal Geologist with AMC Mining Consultants (Canada) Ltd., with an office at Suite 202, 200 Granville Street, Vancouver, British Columbia V6C 1S4.
- 2 This certificate applies to the technical report titled "NI 43-101 Technical Report Update on the GC Ag-Zn-Pb Project in Guangdong Province, People's Republic of China", with an effective date of 30 June 2018, (the "Technical Report") prepared for Silvercorp Metals Inc. ("the Issuer").
- 3 I am a graduate of Kazakh National Polytechnic University (B.Sc. and M.Sc. in Geology, 1987). I am a member in good standing of the Engineers and Geoscientists of British Columbia (License #37412) and the Association of Professional Geoscientists of Ontario (License #1298). I have practiced my profession continuously since 1987 and have been involved in mineral exploration and mine geology for a total of 31 years since my graduation from university. My experience is principally in Mineral Resource estimation, database management, and geological interpretation.

I have read the definition of "qualified person" set out in National Instrument 43-101 (NI 43-101) and certify that by reason of my education, affiliation with a professional association (as defined in NI 43-101) and past relevant work experience, I fulfill the requirements to be a "qualified person" for the purposes of NI 43-101.

- 4 I visited the GC Property from 23 - 25 January 2018 for three days.
- 5 I am responsible for Sections 12 and 14 and parts of 1, 25, and 26 of the Technical Report.
- 6 I am independent of the Issuer and related companies applying all of the tests in Section 1.5 of NI 43-101.
- 7 I have had no prior involvement with the property that is the subject of the Technical Report.
- 8 I have read NI 43-101, and the Technical Report has been prepared in compliance with NI 43-101 and Form 43-101F1.
- 9 As of the effective date of the Technical Report and the date of this certificate, to the best of my knowledge, information and belief, this Technical Report contains all scientific and technical information that is required to be disclosed to make the Technical Report not misleading.

Effective 30 June 2018

Signing Date: 24 July 2018

(original signed by) Dinara Nussipakynova, P.Geo.

Dinara Nussipakynova, P.Geo.
Principal Geologist
AMC Mining Consultants (Canada) Ltd.

CERTIFICATE OF AUTHOR

I, Herbert A. Smith, P.Eng. of Vancouver, British Columbia, do hereby certify that:

- 1 I am currently employed as Senior Principal Mining Engineer with AMC Mining Consultants (Canada) Ltd., with an office at Suite 202, 200 Granville Street, Vancouver, British Columbia V6C 1S4.
- 2 This certificate applies to the technical report titled "NI 43-101 Technical Report Update on the GC Ag-Zn-Pb Project in Guangdong Province, People's Republic of China", with an effective date of 30 June 2018, (the "Technical Report") prepared for Silvercorp Metals Inc. ("the Issuer").
- 3 I graduated with a degree of B.Sc. in Mining Engineering in 1972 and a degree of M.Sc. in Rock Mechanics and Excavation Engineering in 1983, both from the University of Newcastle upon Tyne, England. I have worked as a Mining Engineer for a total of 40 years since my graduation and have relevant experience in underground mining, feasibility studies, and technical report preparation for mining projects.

I have read the definition of "qualified person" set out in National Instrument 43-101 (NI 43-101) and certify that by reason of my education, affiliation with a professional association (as defined in NI 43-101) and past relevant work experience, I fulfill the requirements to be a "qualified person" for the purposes of NI 43-101.

- 4 I visited the GC Property from 24 - 26 January 2018 for three days.
- 5 I am responsible for Sections 2 to 6, 15, 16, 18 to 22, 24, 27 and parts of 1, 25 and 26 of the Technical Report.
- 6 I am independent of the Issuer and related companies applying all of the tests in Section 1.5 of NI 43-101.
- 7 I have had no prior involvement with the property that is the subject of the Technical Report.
- 8 I have read NI 43-101, and the Technical Report has been prepared in compliance with NI 43-101 and Form 43-101F1.
- 9 As of the effective date of the Technical Report and the date of this certificate, to the best of my knowledge, information and belief, this Technical Report contains all scientific and technical information that is required to be disclosed to make the Technical Report not misleading.

Effective 30 June 2018
Signing Date: 24 July 2018

(original signed by) Herbert A. Smith, P.Eng.

Herbert A. Smith, P.Eng.
Senior Principal Mining Engineer
AMC Mining Consultants (Canada) Ltd.

CERTIFICATE OF AUTHOR

I, Alan Riles, MAIG of Gorokan, New South Wales do hereby certify that:

- 1 I am the Director and Principal Consultant of Riles Integrated Resource Management Pty Ltd with an office at 8 Winbourne Street, Gorokan, NSW 2263, Australia. I am currently engaged as an Associate Principal Consultant Metallurgist with AMC Mining Consultants (Canada) Ltd., with an office at Suite 202, 200 Granville Street, Vancouver, British Columbia V6C 1S4.
- 2 This certificate applies to the technical report titled "NI 43-101 Technical Report Update on the GC Ag-Zn-Pb Project in Guangdong Province, People's Republic of China", with an effective date of 30 June 2018, (the "Technical Report") prepared for Silvercorp Metals Inc. ("the Issuer").
- 3 I graduated with a Bachelor of Metallurgy (Hons Class 1) from Sheffield University, UK in 1974. I am a registered member of the Australian Institute of Geoscientists. I have practiced my profession continuously since 1974, with particular experience in study management, and both operational and project experience in precious and base metal deposits.

I have read the definition of "qualified person" set out in National Instrument 43-101 (NI 43-101) and certify that by reason of my education, affiliation with a professional association (as defined in NI 43-101) and past relevant work experience, I fulfill the requirements to be a "qualified person" for the purposes of NI 43-101.
- 4 I have visited the GC Property for two days in May 2011.
- 5 I am responsible for Sections 13, 17 and parts of 1, 25, and 26 of the Technical Report.
- 6 I am independent of the Issuer and related companies applying all of the tests in Section 1.5 of NI 43-101.
- 7 I have had prior involvement with the property that is the subject of the Technical Report in that I was a qualified person for a previous AMC Technical Report on the GC property in 2012 (filed 6 February 2012, effective date 23 January 2012).
- 8 I have read NI 43-101, and the Technical Report has been prepared in compliance with NI 43-101 and Form 43-101F1.
- 9 As of the effective date of the Technical Report and the date of this certificate, to the best of my knowledge, information and belief, this Technical Report contains all scientific and technical information that is required to be disclosed to make the Technical Report not misleading.

Effective 30 June 2018

Signing Date: 24 July 2018

(original signed by) Alan Riles, MAIG

Alan Riles, MAIG

Director and Principal Consultant - Riles Integrated Resource Management Pty Ltd

CERTIFICATE OF AUTHOR

I, Patrick R. Stephenson, P.Geo., of Vancouver, British Columbia, do hereby certify that:

- 1 I am the Principal of P R Stephenson Consulting Inc., with an office at 301, 1490 Pennyfarthing Drive, Vancouver, British Columbia, V6J 4Z3. I am currently engaged as a subconsultant by AMC Mining Consultants (Canada) Ltd. (AMC), with an office at Suite 202, 200 Granville Street, Vancouver, British Columbia, V6C 1S4.
- 2 This certificate applies to the technical report titled "NI 43-101 Technical Report Update on the GC Ag-Zn-Pb Project in Guangdong Province, People's Republic of China", with an effective date of 30 June 2018, (the "Technical Report") prepared for Silvercorp Metals Inc. ("the Issuer").
- 3 I am a graduate of Aberdeen University in Scotland (B.Sc. (Hons) in Geology in 1971). I am a registered member in good standing of the Engineers and Geoscientists of British Columbia (License #37100) and Saskatchewan (Reg. #28984). I have practiced my profession for a total of 47 years since my graduation and have relevant experience in the preparation of Resource and Reserve statements, due diligence reviews, mining and exploration property valuations, expert witness reports, and independent technical reports across a broad range of metalliferous mining projects.

I have read the definition of "qualified person" set out in National Instrument 43-101 (NI 43-101) and certify that by reason of my education, affiliation with a professional association (as defined in NI 43-101) and past relevant work experience, I fulfill the requirements to be a "qualified person" for the purposes of NI 43-101.

- 4 I have not visited the GC Property.
- 5 I am responsible for Sections 7 to 11, 23 and parts of 1, 25, and 26 of the Technical Report.
- 6 I am independent of the Issuer and related companies applying all of the tests in Section 1.5 of the NI 43-101.
- 7 I have had prior involvement with the property that is the subject of the Technical Report in that I was a qualified person for a previous AMC Technical Report on the GC property in 2012 (filed 6 February 2012, effective date 23 January 2012).
- 8 I have read NI 43-101, and the Technical Report has been prepared in compliance with NI 43-101 and Form 43-101F1.
- 9 As of the effective date of the Technical Report and the date of this certificate, to the best of my knowledge, information and belief, this Technical Report contains all scientific and technical information that is required to be disclosed to make the Technical Report not misleading.

Effective 30 June 2018

Signing Date: 24 July 2018

(original signed by) Patrick R. Stephenson, P.Geo.

Patrick R. Stephenson, P.Geo.
Principal – P R Stephenson Consulting Inc.

Our offices

Australia

Adelaide

Level 1, 12 Pirie Street
Adelaide SA 5000 Australia

T +61 8 8201 1800
E adelaide@amcconsultants.com

Melbourne

Level 29, 140 William Street
Melbourne Vic 3000 Australia

T +61 3 8601 3300
E melbourne@amcconsultants.com

Canada

Toronto

TD Canada Trust Tower
161 Bay Street, 27th Floor
Toronto, ON M5J 2S1 Canada

T +1 416 640 1212
E toronto@amcconsultants.com

Singapore

Singapore

30 Raffles Place, Level 17 Chevron House
Singapore 048622

T +65 6809 6132
E singapore@amcconsultants.com

United Kingdom

Maidenhead

Registered in England and Wales
Company No. 3688365

Level 7, Nicholsons House
Nicholsons Walk, Maidenhead
Berkshire SL6 1LD United Kingdom

T +44 1628 778 256
E maidenhead@amcconsultants.com

Registered Office: Ground Floor,
Unit 501 Centennial Park
Centennial Avenue
Elstree, Borehamwood
Hertfordshire, WD6 3FG United Kingdom

Brisbane

Level 21, 179 Turbot Street
Brisbane Qld 4000 Australia

T +61 7 3230 9000
E brisbane@amcconsultants.com

Perth

Level 1, 1100 Hay Street
West Perth WA 6005 Australia

T +61 8 6330 1100
E perth@amcconsultants.com

Vancouver

200 Granville Street, Suite 202
Vancouver BC V6C 1S4 Canada

T +1 604 669 0044
E vancouver@amcconsultants.com

Russia

Moscow

ul. Bakhrushina 32/1
Moscow 115054 Russian Federation

T +7 495 134 01 86
E moscow@amcconsultants.com